

SZ = VOLL EINGEFAHREN
FULLY RETRACTED
COMPLETEMENT RENTRES

SZA = VOLL AUSGEFAHREN
FULLY EXTENDED
COMPLETEMENT SORTIES

	SF2	SF3	HYDRAULISCHE AUSSCHUBE HYDRAULIC EXTENSIONS EXTENSIONS HYDRAULIQUES
SZ	174 mm 6.85 in	233 mm 9.17 in	
SZA	464 mm 18.26 in	726 mm 28.58 in	

	Gewicht	Weight	Poids
SF2		315 kg	
SF3		345 kg	

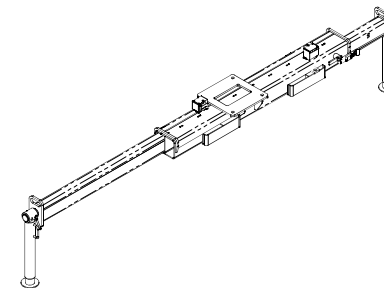
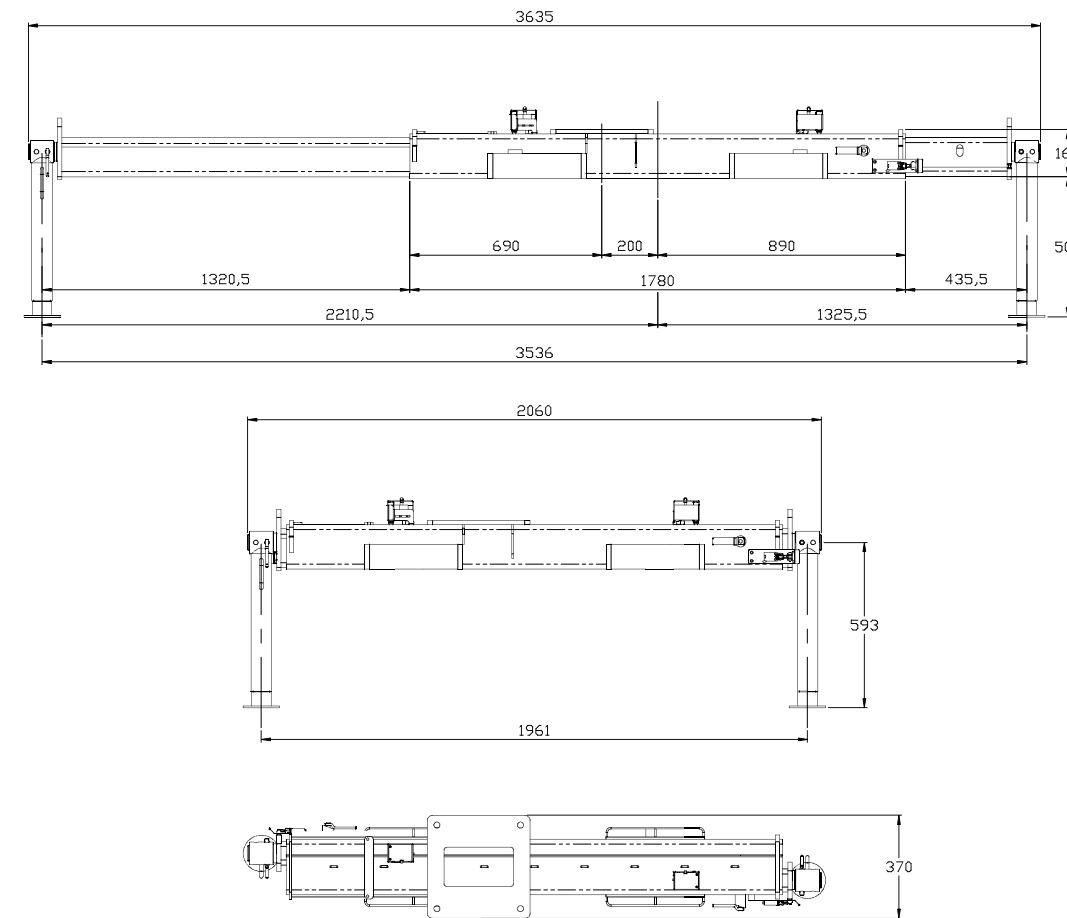

OPTIONAL
BASISVERSION "CE"
BASE "CE" VERSION
VERSION DE BASE "CE"



Konstruktionsänderungen vorbehalten, Angaben unverbindlich, Geräte sind konform mit neuen europäischen Sicherheitsrichtlinien.
Design modifications reserved, specifications non-binding, units are in conformance with new European safety guidelines.
Sous réserve de modifications de la construction, indications sans engagement, les engins sont conformes aux nouvelles directives européennes en matière de sécurité.

Händler:



	SF2	SF3
MAX. HUBMOMENT LIFTING MOMENT COUPLE DE LEVAGE	31.0 kNm (3.2 m) 23145 ft.lbs	31.0 kNm (3.2 m) 23145 ft.lbs
MAX. HUBKRAFT MAX. LIFTING CAPACITY PUISSANCE DE LEVAGE	2150 kg 4740 lbs	2130 kg 4695 lbs
MAX. HYDRAULISCHE REICHWEITE MAX. HYDRAULIC OUTREACH PORTÉE HYDRAULIQUE MAXIMALE	3.85 m 12.63 ft	4.78 m 15.68 ft
SCHWENKBEREICH SLEWING ANGLE ANGLE DE ROTATION	340°	340°
SCHWENKMOMENT SLEWING TORQUE COUPLE DE ROTATION	3.2 kNm (0.33 m) 2390 ft.lbs	3.2 kNm (0.33 m) 2390 ft.lbs
MAX. BETRIEBSDRUCK OPERATING PRESSURE PRESSION D'UTILISATION	18.0 Mpa (180 bar) 2610 psi	18.0 Mpa (180 bar) 2610 psi
EMPFOHLENE FORDERMENGE DER PUMPE RECOMMENDED PUMP CAPACITY DÉBIT DE POMPE RECOMMANDÉ	8 l/min 1.8 imp. gal/min 2.1 US gal/min	8 l/min 1.8 imp. gal/min 2.1 US gal/min

