

# Crawler Tractor

**PR 724**  
Litronic®

Engine Output (SAE J1349): 120 kW / 161 HP  
Engine Output (ISO 9249): 120 kW / 163 HP  
Operating Weight: 16,800 - 20,300 kg  
37,038 - 44,754 lb



# LIEBHERR



# PR 724

Litronic®

Engine Output (SAE J1349):	120 kW / 161 HP
Engine Output (ISO 9249):	120 kW / 163 HP
Operating Weight:	16,800 - 20,300 kg 37,038 - 44,754 lb
Blade Capacity:	3.14 - 4.27 m <sup>3</sup> 4.11 - 5.58 yd <sup>3</sup>
Hydrostatic travel drive with electronic control unit	





## **Performance**

The PR 724 features innovative technology for pure strength. Its high pushing power and unrivalled running smoothness ensure maximum productivity under all operating conditions. Whether on rough terrain or for fine grading – the PR 724 provides excellent performance whatever the application.

## **Economy**

The Liebherr PR 724 gives you clear economic benefits. A highly service-friendly technical concept minimizes downtime and costs. The latest generation of Liebherr diesel engines combined with the efficient drive system ensure maximum economy. High strength components increase service life and therefore return on investment.

## **Reliability**

Powerful and robust: Liebherr crawler tractors are built for longevity in terms of design and choice of materials. Parts subject to heavy wear are made of high-strength materials and critical areas are well protected. All this makes Liebherr crawler tractors highly reliable machines with minimum downtimes.

## **Comfort**

The generation 4 crawler tractors provide the operator with a generously sized workplace designed according to the latest ergonomic principles. The spacious deluxe cab offers an ideal view of the working area and equipment. The machine can be precisely and safely operated using the intuitive single joystick control.







#### Liebherr diesel engine

- The electronically modelled power and torque characteristics offer excellent traction for pushing and ripping.
- Environmentally friendly and economical: meets the latest exhaust emissions standards 2004/26/EC Stage IIIA (EU) and EPA/CARB Tier 3 (US).
- Extra-deep oil pan allows operations at up to 45° incline.
- Designed specifically for construction equipment – provides a long service life and operational reliability.





# Performance

Liebherr has been successfully building hydrostatically driven crawler machines for more than 30 years. The powerful latest-generation PR 724 is the ideal machine for many different applications.

## Excellent grading characteristics

### Long running gear

The long, geometrically optimized undercarriage ensures smooth, extremely low-vibration travel characteristics.

### High-strength main frame construction

The main frame and oscillating bar are particularly resistant to buckling. The oscillating bar with its elastic bearing absorbs vibrations to allow optimum grading.

## High pushing power

### Powerful engine

The characteristics of the new Tier IIIA diesel engine are tuned to the high power required when pushing material and cornering. This provides smooth, powerful power in all situations.

### Drive train for maximum traction

The hydrostatic travel drive requires no gearshifting, the engine power is transmitted to the tracks without interruption – even while steering. This means the operator can comfortably control the travel speed.

## Versatile in use

### Excellent maneuverability

Another strength of the hydrostatic travel drive becomes apparent when operating in confined spaces. All steering movements can be performed quickly and powerfully – right up to true counter rotation.

### Low center of gravity and high ground clearance

The intelligent arrangement of the drive components allows quick and safe work, even on slopes and banks. The PR 724 has sufficient ground clearance to operate on the heaviest soil and roughest terrain.

### A wide range of equipment

Many different blade types, rear attachments and undercarriage configurations variations are available, which means the PR 724 can be ideally configured for multiple applications.



### Grading characteristics

- The ideally positioned blade and the inside-mounted pushing frame give the operator an excellent view of the corners of the blade and the ground underneath.
- The perfectly coordinated front equipment, working hydraulics and the machine itself ensure unsurpassed grading performance and a perfect cut every time.



### Liebherr hydrostat

- The hydrostatic drive offers uninterrupted power transmission and therefore maximum power and safety in every operating situation.
- Power limiting control with automatic speed and torque adjustment ensures maximum efficiency at every speed.



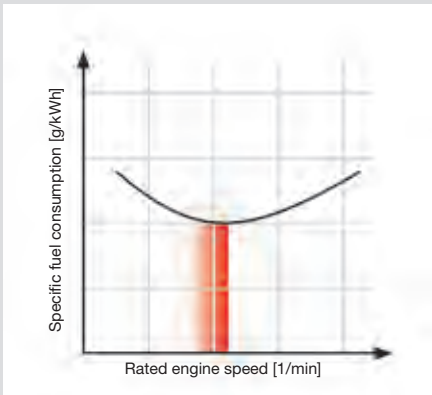

#### Low fuel consumption thanks to steady engine speed

- The rated engine speed falls within the rpm range where specific fuel consumption is lowest. The result is maximum fuel economy without sacrificing power.





# Economy

Liebherr crawlers are always designed with economy in mind. The PR 724's low fuel consumption contributes directly to reducing costs. Long-lasting components and time-saving maintenance greatly increase availability.

## Low fuel consumption

### Steady, low engine speed

The Liebherr diesel engine runs at a steady speed in the most economical range – regardless of the travel speed. This ensures fuel-saving operation. The low piston speed greatly improves the filling of the cylinder chambers which results in more efficient fuel combustion.

### Efficient drive system

The hydrostatic travel drive ensures maximum efficiency at all speeds, even when traveling slowly and reducing power.

### Load sensing working hydraulics

This system makes sure that only the power actually required by the working hydraulics is consumed. Fuel is saved when the attachment is not in use.

## Low service costs

### Long maintenance intervals

The maintenance intervals are optimally specified for the individual components. Maintenance-free solutions are used in areas exposed to dirt.

### Easy access

All the service points on the engine can be accessed from the same side. The hydraulic tilting cab allows easy access to the hydraulic components. Service tasks can be performed quickly and efficiently.

## Long-lasting undercarriage

### Large components

High-quality components with plenty of wear material ensure long undercarriage life and low operating costs.

### Tilting cab

- Allows quick and easy access to all components of the travel drive and working hydraulics.

### Simple maintenance

- All service points are on the same side of the machine. This makes the daily machine inspection very easy and time-saving.



### Optimized transport width

- The six-way blade with folding corners allows a transport width of less than 3 metres (10 feet). This means that the machine can be quickly and easily moved with no loss of productivity.





**Key technologies developed by Liebherr**

- Liebherr has decades of experience in developing, designing and manufacturing components.
- Key components such as engines, transfer gears, hydraulic components and final drives are manufactured in-house assuring the highest degree of quality.





# Reliability

The high quality and established technology of the PR 724 make it a machine of the highest reliability. Specially developed components for use in construction machinery and durable cast steel parts at points under heavy stress guarantee stability even in the most demanding situations.

## Liebherr drive train

### Liebherr engine

Liebherr diesel engines have been developed for the harshest operating conditions. The rigid ladder frame ensures stability, while the low rated engine speed guarantee reliability and long service life.

### Wear-free drive concept

The tried-and-tested hydrostatic travel drive does without components such as the torque converter, shifting gear and differential steering or steering clutches. The standardized hydraulic pumps and motors operate practically without wear.

### Long-lasting final drives

The large final drives in Generation 4 machines are extremely robust and designed for very high loads. The double seal with automatic leak monitoring offers reliable protection.

## Robust steel construction

### Box-type main frame

The main frame is a box-type design. This makes it extremely resistant to buckling and easily able to absorb the forces applied to it. Parts subject to heavy strain are made of cast steel.

## Intelligent solutions for continuous operation

### Innovative cooling system

The electrically controlled hydrostatic fan regulates the operating temperature independently of the engine speed. This lowers fuel consumption and shortens the time it takes to warm up the engine. The extra-large radiator fins achieve an excellent self-cleaning effect.

### High-quality wiring harness protection

High-quality braided protection and an intelligently planned wiring harness prevent condensation from forming and provide lasting protection against mechanical damage.

### Endurance-tested components

- As early as the design phase, components are sized using FE analysis and optimized to handle the loads and stresses of the machine.
- The components are then subjected to intensive endurance testing in the laboratory and in the field. Only those components which meet the high quality standards are used in the machines.



### State-of-the-art cooling system

- The hydrostatically driven fan regulates the cooling power as necessary: so the engine reaches the ideal operating temperature faster.
- The cooling air is drawn in from zones protected from dirt, and flows smoothly through the radiator. This minimizes wear from dust particles.
- An optional reversing fan is available for quick cleaning of the radiator and engine compartment by changing the direction of the airflow.





#### Intuitive single joystick control

- Precise control ranges: Three travel speeds can be preselected and individually programmed using the joystick buttons. Default settings:  
 Level 1: 0 – 2.5 mph  
 Level 2: 0 – 4.0 mph  
 Level 3: 0 – 6.8 mph
- Memory function:  
 All the programmed settings are saved after the machine is restarted.



#### Inch/brake pedal

- In addition to the travel joystick, the operator can use the foot pedal to control the speed and activate the braking function as required.  
 1) Inching function  
 2) Braking function





# Comfort

The redesigned workplace offers the operator a remarkable degree of comfort. Spacious, quiet and designed with ergonomics in mind, Liebherr comfort cabs offer the ideal conditions for fatigue-free, concentrated work. Excellent visibility facilitates safe and precise operation.

## A top-class cab

### Ergonomics

The ergonomically-designed operator's cab offers the ideal environment for relaxed, productive work. All instruments and operating controls are laid out comprehensibly and within easy reach.

### Low sound values

The sound level in a Liebherr cab is far below the legal requirement. The PR 724 boasts exemplary noise values thanks to effective cab sound-proofing and state-of-the-art, quiet diesel engines.

### Outstanding visibility

The integrated ROPS/FOPS protection structure and large window area afford the operator optimum visibility.

## Straightforward and precise control

### Single joystick control

All travel movements can be controlled easily and precisely with only one joystick – including the “counter rotation” function.

### Continuously variable control

Speed selection is continuously variable without gear-shifting and therefore without interrupting drawbar pull.

### Safety in every situation

The crawler tractor is driven with positive power transmission at all times, even on gradients. The self-locking action of the system (hydrostatic drive) allows the operator to control braking simply by reducing joystick movement.

The machine is equipped with an automatic parking brake that is activated when the machine is stationary.



### Instrument display

- The instrument display is ideally positioned in the operator's field of view
- Automatic monitoring, indication and warning of unusual conditions during operation.

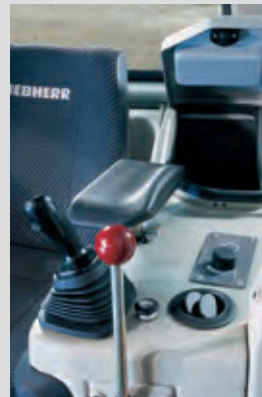

### Intelligent details

- Large storage compartment with a 12 V outlet.
- The flexible, adjustable seat with three armrest positions provides a comfortable working position.
- Other details such as sliding windows, tinted glass and foot rests further increase comfort.



# Basic machine



## Engine

Liebherr diesel engine	D 934 L A6 Emission regulations according to 97/68/EC, 2004/26/EC Stage IIIA and EPA/CARB Tier 3
Rating (SAE J1349)	120 kW / 161 HP
Rating (ISO 9249)	120 kW / 163 HP
Rated speed	1,800 rpm
Displacement	7.0 l / 427 in <sup>3</sup>
Design	4-cylinder in-line engine, water-cooled, turbocharged, air-to-air intercooler
Injection system	Direct fuel injection, pump-line-nozzle system, electronic control
Engine lubrication	Pressurized lube system, engine lubrication guaranteed for inclinations up to 45-degree
Operating voltage	24 V
Alternator	80 A
Starter	5.4 kW
Batteries	2 x 170 Ah / 12 V
Air cleaner	Dry-type air cleaner with pre-cleaner, main and safety elements, control light in the operator's cab
Cooling system	Combi radiator, for water, hydraulic fluid, fuel, charge air. Hydrostatic fan drive



## Travel drive, control

Transmission system	Variable hydrostatic travel drive, independent drive for each track frame
Travel speed *	Continuously variable
Speed range 1 (reverse)	0–4.0 km/h / 2.5 mph (4.8 km/h / 3.0 mph)
Speed range 2 (reverse)	0–6.5 km/h / 4.0 mph (7.8 km/h / 4.8 mph)
Speed range 3 (reverse)	0–11.0 km/h / 6.8 mph (11.0 km/h / 6.8 mph) * Travel speed ranges can be set on the travel joystick (memory function)
Drawbar pull	235 kN at 1.5 km/h / 52,839 lbf at 0.9 mph
Litronic-System	Electronic engine speed sensing control (load-sensing feature) automatically adjusts travel speed and drawbar pull to match changing load conditions
Steering	Hydrostatic
Service brake	Hydrostatic (self locking), wear-free
Parking brake/emergency brake	Multi-disc brake, wear-free, automatically applied with neutral joystick position
Cooling system	Hydraulic oil cooler, integrated in combi radiator
Filter system	Micro cartridge filters in cooling circuit
Final drive	Combination spur gear with planetary gear, double sealed (duo cone seals) with electronic seal-integrity indicator
Control	Single joystick for all travel and steering functions and counter rotation



## Operator's cab

Cab	Resiliently mounted cab with enclosed positive pressure ventilation, can be tilted with the hand pump 40° to the rear. With integrated ROPS Rollover Protective Structure (EN ISO 3471) and FOPS Falling Objects Protective Structure (EN ISO 3449)
Operator's seat	Fully adjustable comfort seat adjustable to operator's weight
Monitoring	Combined analog / LC display, automatic monitoring of abnormal operating conditions



## Track frame

	L	XL	LGP
Mount	Via separate pivot shafts and an oscillating equalizer bar		
Chains	Lubricated, single grouser pads, tension via steel spring and grease tensioner		
Links	42	46	46
Track rollers/carrier rollers	7/2	8/2	8/2
Sprocket segments	5	5	5
Track pads width standard	508 mm (20")	508 mm (20")	711 mm (28") 812 mm (32")
Track pads width option	560 mm (22") 610 mm (24")	560 mm (22") 610 mm (24")	914 mm (36")



## Noise emissions

Operator sound exposure	$L_{pA} = 77$ dB(A)
ISO 6396	(emission at the operator's position)
Exterior sound pressure	$L_{wA} = 109$ dB(A)
2000/14/EC	(emission in the environment)



## Drawbar pull PR 724

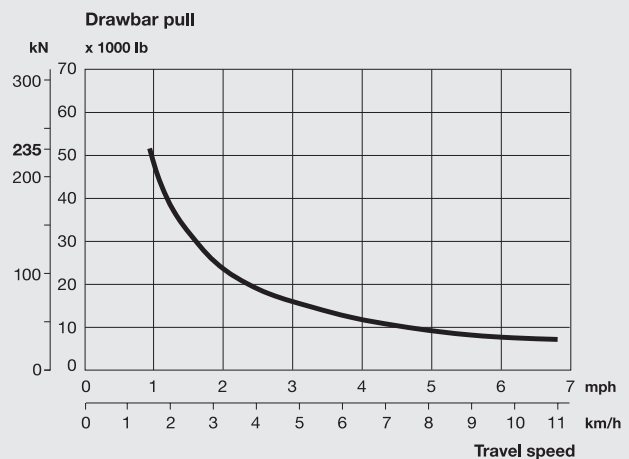



# Basic machine



## Hydraulic equipment

Hydraulic system	Load sensing (demand-controlled)
Pump type	Swash plate piston pump
Pump flow max.	169 l/min / 44.6 gpm
Pressure limitation	200 bar / 2,900 psi
Control valve	2 segments, expandable to 4
Filter system	Return filter with magnetic rod in the hydraulic tank
Control	Single four-way joystick for all blade functions



## Refill capacities in US gallons

Fuel tank	365 l (96.4 gal)
Cooling system	30 l (7.9 gal)
Engine oil with filter	29 l (7.7 gal)
Splitter box	3.0 l (0.8 gal)
Hydraulic tank	144 l (38.0 gal)
Final drive L/XL, each	15 l (4.0 gal)
Final drive LGP, each	20 l (5.3 gal)

# Dimensions

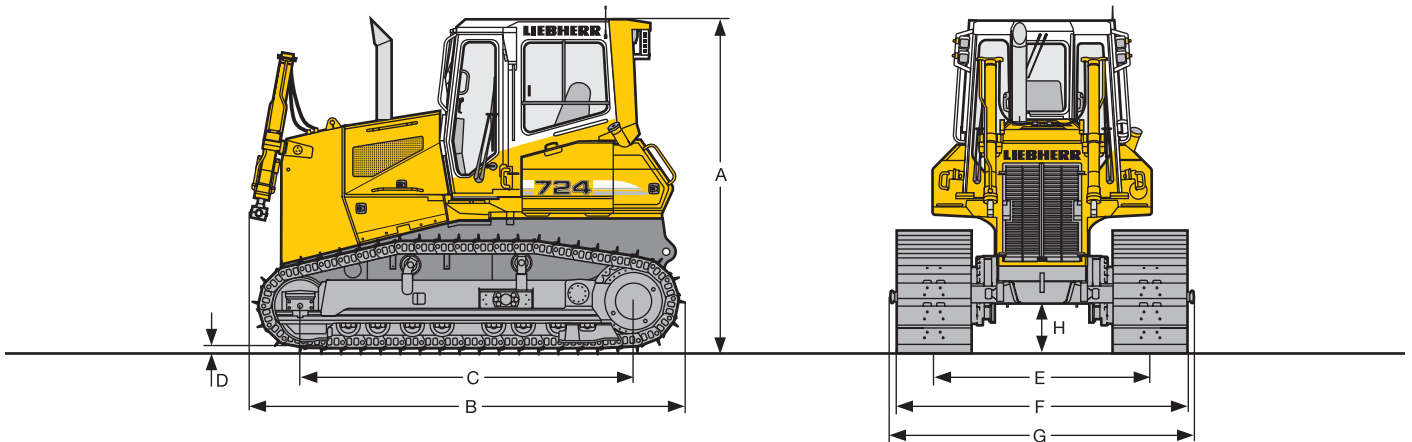

Dimensions		PR 724 L	PR 724 XL	PR 724 LGP
A	Height over cab	mm 3,197	mm 3,197	mm 3,197
		ft-in 10'6"	ft-in 10'6"	ft-in 10'6"
B	Overall length without attachments	mm 4,114	mm 4,173	mm 4,173
		ft-in 13'6"	ft-in 13'8"	ft-in 13'8"
C	Distance idler/sprocket centre	mm 2,830	mm 3,210	mm 3,210
		ft-in 9'3"	ft-in 10'6"	ft-in 10'6"
D	Height of grousers	mm 56	mm 56	mm 56
		in 2.2"	in 2.2"	in 2.2"
E	Track gauge	mm 1,800	mm 1,800	mm 2,084
		ft-in 5'11"	ft-in 5'11"	ft-in 6'10"
F	Width above tracks <sup>1</sup>	mm 2,410	mm 2,410	mm 2,998
		ft-in 7'11"	ft-in 7'11"	ft-in 9'10"
G	Width over ball head	mm 2,648	mm 2,648	mm 3,248
		ft-in 8'8"	ft-in 8'8"	ft-in 10'8"
H	Ground clearance	mm 475	mm 475	mm 475
		in 19"	in 19"	in 19"

<sup>1</sup> Track pads 610 mm/24" (L and XL), respectively 914 mm/36" (LGP)



# Front attachment

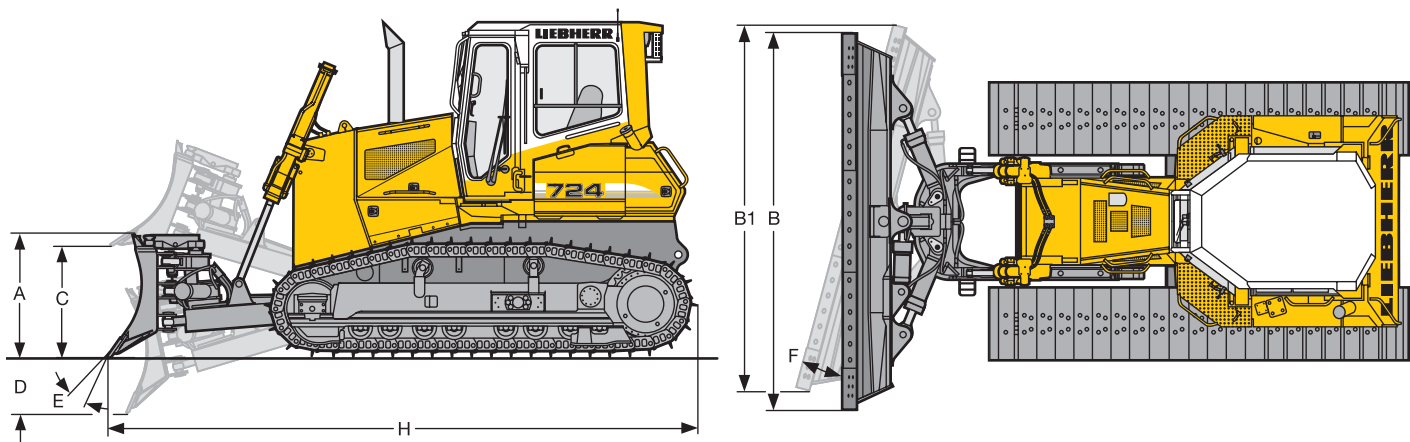

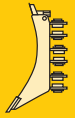
	<b>6-way-blade with inside mounted push frame<sup>1</sup></b>		<b>6-way blade</b>	<b>6-way blade with hinged corners</b>	<b>6-way blade</b>	<b>6-way blade with hinged corners</b>	<b>6-way blade</b>	<b>6-way blade with hinged corners</b>
			<b>L</b>	<b>L</b>	<b>XL</b>	<b>XL</b>	<b>LGP</b>	<b>LGP</b>
Blade capacity according to ISO 9246	m <sup>3</sup>	3.17	3.17	3.17	3.17	3.39	3.39	3.39
	yd <sup>3</sup>	4.15	4.15	4.15	4.15	4.43	4.43	4.43
A Height of blade	mm	1,200	1,200	1,200	1,200	1,100	1,100	1,100
	ft-in	3'11"	3'11"	3'11"	3'11"	3'7"	3'7"	3'7"
B Width of blade	mm	3,204	3,204	3,204	3,204	3,790	3,790	3,790
	ft-in	10'6"	10'6"	10'6"	10'6"	12'5"	12'5"	12'5"
B1 Width of blade angled	mm	2,997	3,081	2,997	3,081	3,537	3,638	3,638
	ft-in	9'10"	10'1"	9'10"	10'1"	11'7"	11'11"	11'11"
Transport width	mm	2,997	2,430	2,997	2,430	3,537	3,000	3,000
	ft-in	9'10"	8'	9'10"	8'	11'7"	9'10"	9'10"
C Lifting height	mm	1,149	1,149	1,187	1,187	1,174	1,174	1,174
	ft-in	3'9"	3'9"	3'11"	3'11"	3'10"	3'10"	3'10"
D Depth below ground	mm	532	532	510	510	504	504	504
	in	21"	21"	20"	20"	20"	20"	20"
E Max. blade pitch		5°	5°	5°	5°	5°	5°	5°
F Angle adjustment		23°	18°	23°	18°	23°	18°	18°
Max. blade tilt	mm	474	474	474	474	560	560	560
	in	19"	19"	19"	19"	22"	22"	22"
H Overall length, blade straight	mm	5,369	5,369	5,501	5,501	5,468	5,468	5,468
	ft-in	17'7"	17'7"	18'11"	18'11"	17'11"	17'11"	17'11"
Operating weight <sup>2</sup>	kg	16,867	17,202	17,427	17,762	18,437	18,772	18,772
	lb	37,185	37,924	38,420	39,158	40,647	41,385	41,385
Ground pressure <sup>2</sup>	kg/cm <sup>2</sup>	0.49	0.50	0.44	0.45	0.31	0.32	0.32
	PSI	6.97	7.11	6.26	6.4	4.41	4.55	4.55

<sup>1</sup> Optional outside-mounted push frame (See Attachment-Information concerning the 6-way blade with outside-mounted push frame)

<sup>2</sup> Lubricants and fuels, 6-way blade, operator, track pads 610 mm/24" (L and XL) resp. 914 mm/36" (LGP)



# Front attachment

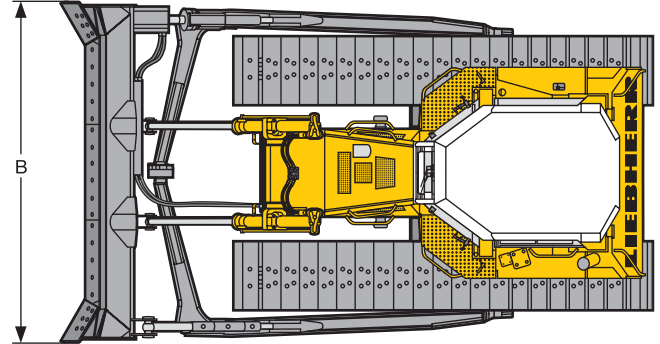
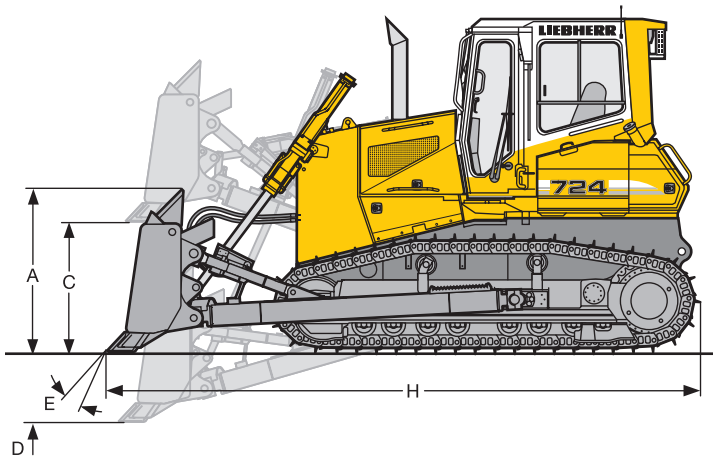



 <b>Semi-U blade and straight blade</b>	<b>Semi-U blade</b>		<b>Straight blade</b>		<b>Straight blade</b>	
	<b>L</b>	<b>XL</b>	<b>L</b>	<b>XL</b>	<b>LGP</b>	
Blade capacity according to ISO 9246	m <sup>3</sup>	4.27	4.27	3.14	3.14	3.43
	yd <sup>3</sup>	5.58	5.58	4.11	4.11	4.49
A Height of blade	mm	1,250	1,250	1,200	1,200	1,100
	ft-in	4'1"	4'1"	3'11"	3'11"	3'7"
B Width of blade	mm	3,000	3,000	3,000	3,000	3,600
	ft-in	9'10"	9'10"	9'10"	9'10"	11'10"
C Lifting height	mm	968	1,062	968	1,062	1,061
	ft-in	3'2"	3'6"	3'2"	3'6"	3'6"
D Depth below ground	mm	419	460	419	460	460
	in	16.5"	18"	16.5"	18"	18"
E Max. blade pitch		10°	10°	10°	10°	10°
Max. blade tilt	mm	639	639	639	639	618
	in	25"	25"	25"	25"	24"
H Overall length, blade straight	mm	5,155	5,535	4,941	5,321	5,316
	ft-in	16'11"	18'2"	16'3"	17'5"	17'5"
Operating weight <sup>1</sup>	kg	16,792	17,287	16,662	17,157	18,322
	lb	37,020	38,111	36,733	37,825	40,393
Ground pressure <sup>1</sup>	kg/cm <sup>2</sup>	0.49	0.44	0.48	0.44	0.31
	PSI	6.97	6.26	6.83	6.26	4.41

<sup>1</sup> Lubrication and operating materials, fuel, semi-U blade/straight blade, operator, track pads 610 mm/24" (L/XL) or 914 mm/36" (LGP)

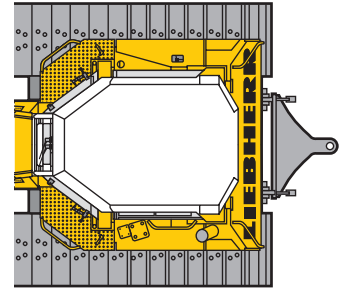
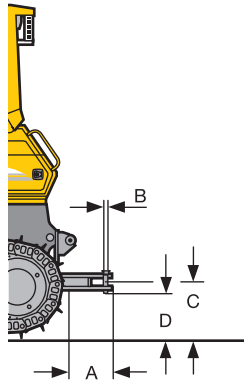
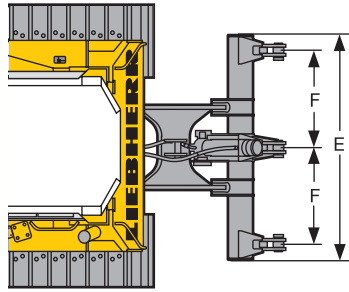
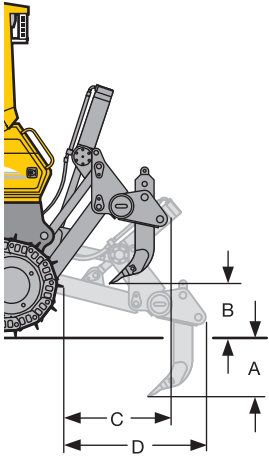

# Rear attachment



	<b>Ripper 3 shanks</b>	<b>Parallelogram</b>
A	Ripping depth (max./min.)	mm ft-in
B	Lifting height (max./min.)	mm ft-in
C	Overall length, attachment raised	mm ft-in
D	Overall length, attachment lowered	mm ft-in
E	Toolbar width	mm ft-in
F	Distance between shanks	mm ft-in
	Weight	kg lb

	<b>Drawbar</b>	<b>Rigid</b>
A	Additional length	mm in
B	Socket pin diameter	mm in
C	Height of jaw	mm in
D	Ground clearance	mm in
	Jaw opening	mm in
	Weight	kg lb



# Equipment



## Basic machine

Tow switch	•
Towing hitch rear	•
Towing lug front	•
Battery compartment, lockable	•
Belly pans, heavy-duty	•
Cold start device, glow plug	•
Radiator, wide-meshed	•
Radiator guard, hinged	•
Liebherr diesel engine	•
Fan, hydraulically driven	•
Fan guard	•
Engine cover, perforated	•
Engine doors, perforated	•
Engine doors, hinged, lockable	•
Lugs for crane lifting	•
Fuel water separator	•
Air filter, dry type, dual step	•
Pre-cleaner with automatic dust ejector	•
Toolkit	•
Forestry equipment	+
Landfill equipment	+
Tank guard, complete	+
Refueling pump, electric	+
Diesel particle filter	+
Radiator guard, heavy-duty	+
Liebherr bio degradable hydraulic oil	+
Fan, hydraulically driven, reversible	+
Special paint	+
Fuel water separator with electric heater	+
Laser/GPS ready kit	+



## Operator's cab

Storage box	•
Armrests 3D adjustable	•
Ash tray	•
Pressurized with air filter	•
Operator's seat, 6-way adjustable	•
Fire extinguisher	•
Dome light	•
Coat hook	•
Air conditioner	•
ROPS/FOPS	•
Rear mirror, inside	•
Safety glass, tinted	•
Windshield washer system	•
Windshield wipers front, rear and on the doors, with intermittent function	•
Sliding window, left	•
Sliding window, right	•
Sun visor	•
Socket 12 V	•
Hot water heating	•
Cooler	+
FM radio	+
Radio pre installation	+
Protective grids for windows	+
Extension, seat back	+



## Track frame

Track frame, closed	•
Sprocket segments, bolted	•
Master link, two-piece	•
Tracks oil-lubricated	•
Track frames, oscillating	•
Pivot shaft, separate	•
Track pads in design ESS	+
Track pads with mud holes	+
Track guide center part	+
Track guard	+
Undercarriage L	+
Undercarriage XL	+
Undercarriage LGP	+
Sprocket segments with recesses	+



## Electrical system

Starter motor 5.4 kW	•
Working lights, front, 4 units	•
Working lights, rear, 2 units	•
Batteries, heavy-duty cold start, 2 units	•
Battery main switch, mechanic	•
On-board system 24 V	•
Back-up alarm	•
Horn	•
Alternator 80 A	•
Beacon	+
Immobilizer, electronic	+
Additional lights, rear	+
Additional lights, front, on the lift cylinders, 4 units	+



## Travel drive

Automatic parking brake	•
Automatic function control	•
Single joystick control	•
Electronic load limit control	•
Electronic control	•
Travel control, 3-speed	•
Hydrostatic travel drive	•
Emergency stop	•
Oil cooler	•
Final drives planetary gear	•
Safety lever	•
Inching brake pedal	+

• = Standard, + = Option

Subject to changes.



## Control and warning lights

Display travel speed range (digital)	•
Engine coolant temperature gauge (analog)	•
Fuel gauge (analog)	•
Hour meter (analog)	•
Warning light battery charging	•
Warning light Diesel engine	•
Warning light electronic travel control system	•
Warning light final drive seal, each side	•
Warning light parking brake	•
Warning light fuel water separator	•
Warning light fan control	•
Warning light pump replenishing pressure	•
Warning light float position blade	•
Warning light oil return filter	•
Warning light air filter	•
Warning light Diesel engine preheating	•
Main warning light	•
Warning light hydraulic oil temperature	+



## Hydraulic equipment

Variable flow pump, load-sensing	•
Oil filter in hydraulic tank	•
Blade quick drop	•
Control block for 2 circuits	•
Float position blade	•
Hydraulic servo control	•
Hydraulic control ripper	+
Hydraulic control winch	+
Hydraulic tank oil level warning light	+



## Attachments

Mounting plate for external tools	+
Rigid, rear drawbar	+
Swiveling rear drawbar	+
Counterweight, rear	+
Ripper 3 shanks	+
Bumper rear	+
6-way blade with inside mounted push frame	+
6-way blade with outside mounted push frame	+
Straight blade	+
Semi-U blade	+
Winch	+
Spill guard for blade	+

Options and/or special attachments, supplied by vendors other than Liebherr, are only to be installed with the knowledge and approval of Liebherr to retain warranty.



# The Liebherr Group of Companies

## Wide Product Range

The Liebherr Group is one of the largest construction equipment manufacturers in the world. Liebherr's high-value products and services enjoy a high reputation in many other fields, too. The wide range includes domestic appliances, aerospace and transportation systems, machine tools and maritime cranes.

## Exceptional Customer Benefit

Every product line provides a complete range of models in many different versions. With both their technical excellence and acknowledged quality, Liebherr products offer a maximum of customer benefits in practical application.

## State-of-the-art Technology

To provide consistent, top quality products, Liebherr attaches great importance to each product area, its components and core technologies. Important modules and components are developed and manufactured in-house, for instance the entire drive and control technology for construction equipment and mining trucks.

## Worldwide and Independent

Hans Liebherr founded the Liebherr family company in 1949. Since that time, the enterprise has steadily grown to a group of more than 100 companies with over 32,000 employees located on all continents. The corporate headquarters of the Group is Liebherr-International AG in Bulle, Switzerland. The Liebherr family is the sole owner of the company.

[www.liebherr.us](http://www.liebherr.us)



Printed in Germany by DWS RG-BK-RP LWT/VM 10467521-1-02.11\_enUS

**Liebherr Construction Equipment Co.**  
4100 Chestnut Avenue, Newport News, VA 23607, USA  
☎ +1 (757) 245 5251, Fax +1 (757) 928 8701  
[www.liebherr.us](http://www.liebherr.us), E-Mail: [info.lce@liebherr.com](mailto:info.lce@liebherr.com)