

Wheel Loaders

# L 524 - L 580

**Generation**

5

**Tipping load**

7,500 kg – 18,000 kg

**Engine**

Stage II

Stage IIIA



# LIEBHERR

## Performance

Power for Increased  
Productivity

## Economy

Minimum Costs at  
High Handling Capacity

### L 524

**Tipping load, articulated** 7,500 kg

**Bucket capacity** 2.0 m<sup>3</sup>

**Operating weight** 10,400 kg

**Engine output (ISO 14396)**

86 kW / 117 HP

### L 538

**Tipping load, articulated** 9,500 kg

**Bucket capacity** 2.5 m<sup>3</sup>

**Operating weight** 12,800 kg

**Engine output (ISO 14396)**

104 kW / 141 HP

### L 550

**Tipping load, articulated** 12,350 kg

**Bucket capacity** 3.2 m<sup>3</sup>

**Operating weight** 17,350 kg

**Engine output (ISO 14396)**

140 kW / 190 HP

### L 566

**Tipping load, articulated** 15,550 kg

**Bucket capacity** 4.0 m<sup>3</sup>

**Operating weight** 23,100 kg

**Engine output (ISO 14396)**

200 kW / 272 HP

### L 580

**Tipping load, articulated** 18,000 kg

**Bucket capacity** 5.0 m<sup>3</sup>

**Operating weight** 24,720 kg

**Engine output (ISO 14396)**

200 kW / 272 HP



## Reliability

Robustness and Quality  
for Durable Machines

## Comfort

Maximum Operator Comfort  
for More Productivity

## Maintainability

Time and Cost Savings  
Through Simple Maintenance



# Performance



## Power for Increased Productivity

The innovative Liebherr driveline considerably increases working efficiency. Quick working cycles, high tipping loads and high machine availability lead to increased handling capacity.

# Powerful and Efficient Machine Concept

## Highest Level of Performance

The high-performance Liebherr wheel loaders L 524 – L 580 impress in every field of application due to their great productivity and efficiency. High tipping loads at low operating weight permit a high handling capacity. Strong construction and rugged steel components result in reliable and powerful performance. All of the components are perfectly adapted to each other, making the Liebherr wheel loaders the perfect solution for all applications, especially for industrial use. The wide variety of options for specific requirements also increase the range of possible applications.

## Continuously Variable Transmission

The Liebherr driveline allows continuous regulation of acceleration in all speed ranges, without noticeable gear shifting or interruption in tractive force. Powerful working and high driving comfort increases your productivity.

## High Handling Capacity

Unnecessary counterweight can be avoided through the unique component mounting position at the rear of the machine. Ideal weight distribution results in higher tipping loads at significantly lower operating weight, compared with conventional wheel loaders. The handling capacity per operating hour increases and fuel consumption is further reduced thanks to the low operating weight.

# Flexibility and Versatility

## Lift Arm Variants Optimised for the Application

The standard Z-bar linkage provides a large torque in the lower region of the lift arm. The ideal prerequisite for conventional wheel loader applications – simple, quick filling of the bucket leads to high handling capacity.

An alternative is available in the form of the parallel linkage for L 524 – L 538 or the industrial lift arm for L 550 – L 580 wheel loaders. The parallel linkage or the industrial lift arm boasts a parallel guide arrangement and especially high torque in the upper lifting range. The best solution for industrial use as it allows large attachments to be fitted for transporting heavy loads.

## Optimal Bucket Filling

The robust bucket design from Liebherr allows the bucket to be filled quickly and efficiently. Fully filled attachments increase productivity. The bucket's good penetration and simple filling mechanism result in lower fuel consumption.

## Wide Range of Applications

The wide range of attachments means the right tool is always to hand. As a result, a multitude of uses can easily be covered. This increases utilisation of the machine and raises productivity. Liebherr wheel loaders can manoeuvre quickly and efficiently thanks to their compact design – the best choice for high handling capacity.

### Liebherr Driveline

#### L 524 – L 580

- Optimum weight distribution due to its unique component mounting position
- Higher tipping loads at low operating weight
- Ideal visibility due to its compact design

### Higher Productivity

#### at Lower Weight

- L 524 – L 550 transverse installation of the diesel engine
- L 566 – L 580 lengthways-installed diesel engine, output shaft is facing to the rear
- Components act as counterweight

### Conventional

#### Travel Gear

- Centre of gravity in the middle of the machine
- Additional ballast is needed to increase the tipping load and improve stability
- This leads to high operating weight and bad visibility

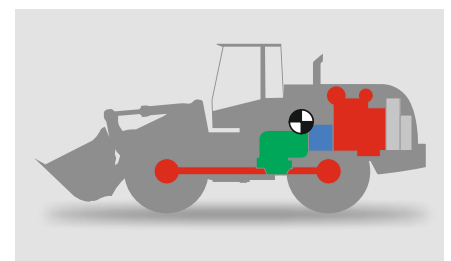
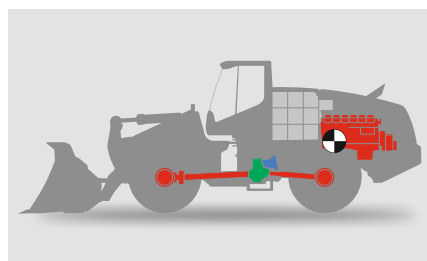
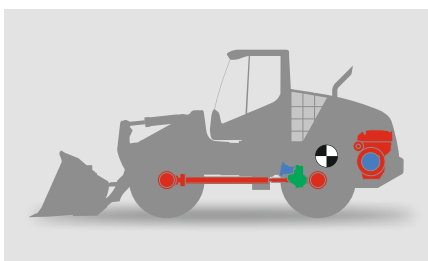

# Economy



## Minimum Costs at High Handling Capacity

Liebherr wheel loaders make a reliable contribution to commercial success. The fuel-efficient drive concept reduces operating costs and environmental impact at maximum handling capacity.

# Low Operating Costs

## Lower Fuel Consumption

With Liebherr wheel loaders it is simple to do more, moving larger volumes of material with less fuel compared with conventional wheel loaders. The Liebherr driveline achieves a reduction in fuel consumption of up to 25%. At highest efficiency this reduces operating costs and increases profitability.

## Hardly Any Brake Wear

The Liebherr driveline brakes automatically. The service brake only acts as a support and is therefore subject to hardly any wear.

## Minimal Tyre Wear

Its continuous traction control, combined with automatic self-locking differential, prevents wheelspin. Productivity is increased and tyre wear reduced by up to 25%.

## Economical Use of Resources

The lower fuel consumption cut emissions. This actively saves resources. While actively protecting the environment, Liebherr wheel loaders reduce operating costs.

# LiDAT

## Efficient Management

LiDAT, Liebherr's own data transmission and positioning system, facilitates efficient management, monitoring and control of the entire fleet park in terms of machinery data recording, data analysis, fleet park management and service. All of the important machinery data can be viewed at any time in a web browser. LiDAT offers you comprehensive work deployment documentation, greater availability thanks to shorter downtimes, faster support from the manufacturer, quicker detection of strain/overload and subsequently a longer service life of the machine as well as greater planning efficiency in your company.

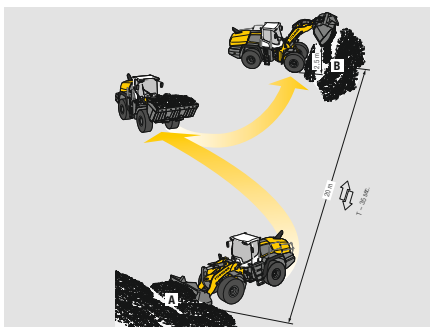

### Lower Fuel Consumption

- A fuel saving of up to 5 litres per operating hour represents a cost saving of up to 25%
- The Liebherr Standard Consumption Test demonstrates the operating efficiency of Liebherr wheel loaders

### Reduced Brake Wear

- Hardly any brake wear due to hydraulic braking action of the driveline

### Reduced Tyre Wear

- Continuous traction control prevents the wheels from spinning

### Always Be Informed with LiDAT

- Evaluation of machine usage and fuel consumption for economic machine management
- High availability and fast support from the manufacturer

# Reliability



## Robustness and Quality for Durable Machines

Liebherr wheel loaders provide maximum performance even under the toughest of operating conditions. Specially-developed components, sophisticated technology and high quality offer a high level of reliability and availability.



## OEM Quality Components

### Durable and Powerful

Liebherr has many decades of experience in the development, construction and production of components. Ideally adapted to each other, they guarantee a high degree of performance and reliability. Liebherr also develops and produces all steel components. These rugged components ensure the long life of the wheel loaders.

Strenuous endurance tests prove to the strength and quality of the components in use. Even under the toughest of usage conditions, Liebherr wheel loaders satisfy Liebherr's stringent quality standards. This ensures reliable use throughout the entire life time of the machine. Consistently powerful machines increase productivity.

### High Safe and Versatile Usage

The components of the tried and tested hydrostatic Liebherr driveline are extremely robust and powerful. This ensures that the machine has a long life time and will work reliably even under the toughest of operating conditions.

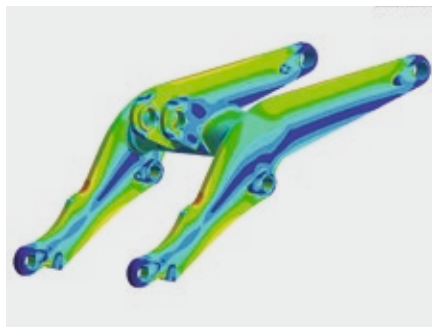

## Reliable Cooling System

### Optimal Cooling Performance

The cooling system is fitted directly behind the operator's cab and is thus able to take in air which is free of dust. In especially dusty applications, optional equipment such as reversible fan drive, fluff trap for the radiator and large-mesh radiator protect the cooling system from contaminants getting in. This guarantees continuous cooling output while simultaneously reducing cleaning expenses. Minimal cleaning expenses mean more efficient, more cost-effective working.

### Controlled Cooling

The cooling fan is driven independently from the diesel engine and produces exactly the cooling air output which is actually required. Heat sensors ensure reliable control.

### Powerful Liebherr's Own Components

- Ideal interaction of components to each other for maximum performance
- Maximum quality even under the toughest operating conditions
- Rugged, durable machines for reliable operations

### Intelligent Cooling System

- Cooling position on the cleanest position of the wheel loader
- High machine availability thanks to lower radiator contamination
- Controlled cooling through thermostatic control for reliable operations

### High Machine Availability

- L 524 – L 550 cooling air is drawn in directly behind the cabin and blown out upwards at the rear
- L 566 – L 580 lengthways-installed cooler package for improved visibility and easier cleaning and maintenance
- High, safe and versatile usage thanks to robust and powerful components

# Comfort



## Maximum Operator Comfort for More Productivity

The cab design is optimally adapted to the operator's day-to-day requirements. The roomy and ergonomic operator's cab offers perfect conditions for comfortable and productive work.

## Clearly Arranged Cab

### Productive and Safe Working

The modern, ergonomic cab design allows the operator to work with high concentration without fatigue – this increases safety and productivity. The displays, controls and operator's seat are carefully coordinated to form an ergonomic unit. The optional air-suspended operator's seat offers high seating comfort and relaxed working.

### Perfect Visibility

The generous glass surfaces of the cab offer exceptional all-round visibility of the attachment and working area. The design of the engine hood which has been optimised for viewing and the optional rear space camera provide ideal viewing towards the rear. This ensures maximum safety for people, the machine and the load, while increasing productivity at the same time.

### Well-Being Guaranteed

Optimum storage areas and stowage spaces increase operator well-being. The air conditioning system as standard ensures a pleasant working atmosphere. This gives the operator maximum comfort and high productivity.

## Simple and Intuitive Operation

### Ergonomic Controls

The operating and control instruments are well laid out and user-friendly. All operation-relevant data can be viewed quickly and efficiently. The high operating comfort allows the operator to work particularly efficiently and safely.

### Liebherr Control Lever

The Liebherr control lever allows all working and manoeuvring operations to be performed with a high degree of precision and sensitivity. This means accurate and safe handling, and the left hand always remains on the steering wheel. This increases safety at the job site.

The proportional control of hydraulic attachment is carried out by the Liebherr control lever with mini-joystick which is optional for L 566 – L 580. The hydraulic attachment can be controlled with great sensitivity and very ergonomically.

### Exceptional All-Round Visibility

- Unobstructed visibility in all directions through optimal cab and engine hood design
- Generous glass surfaces
- More safety and productivity thanks to exceptional visibility

### Powerful Air-Conditioning System

- Greatest operator comfort for high productivity
- Exceptional cooling output due to 4-level air control

### Liebherr Control Lever

- Ergonomic and comfortable operation
- Control all driving and operating manoeuvres with a single control lever
- Precise, sensitive and safe control of the machine



# Maintainability



## Time and Cost Savings Through Simple Maintenance

The most important points for daily maintenance of Liebherr wheel loaders can be reached safely and conveniently from the ground. Quick and safe checks save time and money.

# Exceptional Service Accessibility

## Efficient and Simple Maintenance

Thanks to the unique mounting position of the components, Liebherr wheel loaders offer exceptional accessibility for maintenance. The positioning of the cooling package directly behind the operator's cab lowers contamination of the cooling system, reducing maintenance and cleaning requirements and saving time and money.

## Safe and Free Service Access

All points requiring day-to-day maintenance can be reached comfortably, safely and cleanly. Cleaning of the cooling system is carried out while standing on the machine, anti-slip steps and sturdy handrails provide a high degree of safety.

## Short Service Times for More Productivity

At L 524 – L 550 the entire engine compartment is accessible via just one access panel. Service points are easy to see and reach. Maintenance work can be carried out comfortably and safely from the ground. This ensures time-saving maintenance and increases productivity.

At L 566 – L 580 most access points for daily maintenance can be reached from ground level, by opening one access panel. Work on the diesel engine and pump distributor gear is carried out while standing on the machine. Great care has been taken to ensure maximum safety in these areas as well.

### Low Maintenance

- Less contamination of the radiator thanks to its clever position behind the operator's cab
- Quick and safe control saves time and money

### Optimum Service Accessibility

- Most access points for daily maintenance are accessible via just one enclosure
- Most important points for daily maintenance can be reached from the ground
- Short downtimes means more efficiency

### Perfect Service for Optimum Machine Availability

- Quick and effective support thanks to an extensive service network
- Quick replacement part provision
- Quick and reliable service carried out by qualified service specialists



# Strong Service Partner

## Safe Partnership with Strong Service

When buying a Liebherr wheel loader the customer not only looks to a long-lived high-end product but also a reliable longterm partnership. A service network combined with a highly-modern central warehouse is available for optimum service and quick replacement part provision. This guarantees short routes and rapid support in the event of service. Round-the-clock if required.

## Competent Liebherr Service Offers Maximum Reliability

Comprehensive know-how ensures a first-class execution of all service and maintenance work. This contributes decisively to the availability and profitability of your machine. Employees at Liebherr service partners are trained on an ongoing basis. They have extensive knowledge of quick and safe service performance. They can turn to the expertise of manufacturing plants at any time.

# Wheel Loaders L 524 - L 580

## Overview

---

### Sturdy Attachment

- + Quick working cycles
- + Robust, durable lift arm
- + Flexible in use
- + Efficient and cost-optimised use by specially adapted lift arm variants

- ✓ High-quality hydraulic components
- ✓ Strong steel construction
- ✓ Wide range of attachments
- ✓ Z-bar linkage and parallel linkage/industrial lift arm optional

### Powerful and Efficient Liebherr Driveline

- + Fuel benefit of up to 25 %
- + High performance
- + High safe and versatile usage
- + Maximum productivity by high tipping load
- + Tyre wear reduced by up to 25 %
- + Practically no brake wear
- + Maximum stability and safety on all terrains

- ✓ Most efficient hydrostatic driveline
- ✓ Drive components optimally suited to each other
- ✓ Rugged and durable driveline
- ✓ Ideal weight distribution by intelligent arrangement of drive components
- ✓ Continuous tractive force prevents wheelspin
- ✓ Self-locking hydraulic brake system





### **Comfortable Operator's Cab**

- + Increased performance and productivity
- + Focused operator work is supported
- + Easy and safe operation
- + Excellent all-round visibility

- ✓ Modern and ergonomic cab design
- ✓ Control of working and travel functions with one control lever
- ✓ Generous glass surfaces

### **Intelligent Cooling System**

- + Constant and reliable cooling
- + Increased service life of components
- + High machine availability through minimal cleaning expenses

- ✓ Controlled cooling
- ✓ Heat sensors ensure reliable control
- ✓ The radiator is installed directly behind the operator's cab – the cleanest position of the wheel loader

### **Optimum Service Accessibility**

- + Time savings in daily maintenance
- + Short service times for more productivity
- + High availability and fast support from the manufacturer

- ✓ Rapid control of the most important maintenance points from the ground
- ✓ Safe, simple and quick access to all points important for operations
- ✓ LiDAT – fleet park management for machinery data recording and diagnostics

# Technical Data

L 524 / L 538



## Engine

	L 524	L 538
<b>Diesel engine</b>	4045HF286	4045HF286
Design	Water-cooled, turbo charged, intercooled	
Cylinder inline	4	4
Fuel injection process	Electronic Common Rail high-pressure injection	
Max. gross output to ISO 3046	kW/HP 86/117	104/141
and SAE J1995	at RPM 2,200	2,200
Max. net output to ISO 9249	kW/HP 85/116	102/139
and SAE J1349	at RPM 2,200	2,200
Rated output to ISO 14396	kW/HP 86/117	104/141
	at RPM 2,400	2,400
Max. net torque to ISO 9249	Nm 416	508
and SAE J1349	at RPM 1,400	1,400
Displacement	litres 4.5	4.5
Bore/Stroke	mm 106/127	106/127
<b>Air cleaner system</b>	Dry air filter with main and safety element, pre-cleaner, service indicator	
<b>Electrical system</b>		
Operating voltage	V 24	24
Battery	Ah 2 x 135	2 x 135
Alternator	V/A 28/100	28/100
Starter	V/kW 24/7	24/7

The exhaust emissions are below the limits in stage IIIA.



## Driveline

### Continuous hydrostatic driveline

Design	Swash plate type variable flow pump and two variable axial piston motors in closed loop circuit and axle transfer case. Direction of travel is reversed by changing the flow-direction of the variable-displacement pump
Filtration	Suction return line filter for closed circuit
Control	By travel and inching pedal. The inching pedal makes it possible to control the tractive and thrust forces steplessly at full engine speed. The Liebherr control lever is used to control forward and reverse travel
<b>Travel speed range</b>	Speed range 1 _____ 0 – 4 km/h Speed range A1 – 2 _____ 0 – 15 km/h Speed range A1 – 3 _____ 0 – 40 km/h forward and reverse Speeds quoted apply with the tyres indicated as standard on loader model.

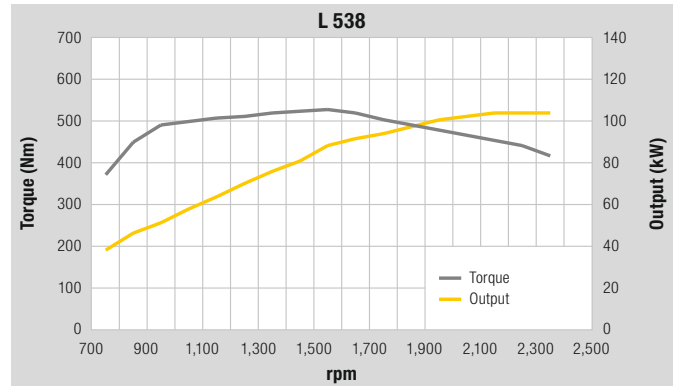
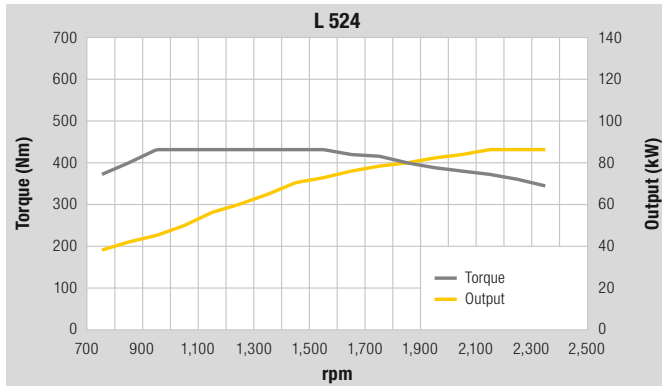



## Axles

	L 524	L 538
<b>Four-wheel drive</b>		
<b>Front axle</b>	Fixed	
<b>Rear axle</b>	Centre pivot, with 10° oscillating angle to each side	
Height of obstacles which can be driven over	mm 470	470
	with all four wheels remaining in contact with the ground	
<b>Differentials</b>	Automatic limited-slip differentials	
<b>Reduction gear</b>	Planetary final drive in wheel hubs	
<b>Track width</b>	1,960 mm with all types of tyres (L 524) 1,900 mm with all types of tyres (L 538)	



## Brakes

<b>Wear-free service brake</b>	Self-locking of the hydrostatic driveline (acting on all four wheels) and additional pumpaccumulator brake system with wet multi-disc brakes located in the differential housing (two separate brake circuits)
<b>Parking brake</b>	Electro-hydraulically actuated spring-loaded disc brake system on the front axle

The braking system meets the requirements of the ISO 3450.



## Tyres

<b>Standard size L 524</b>	17.5R25 L3
<b>Standard size L 538</b>	20.5R25 L3
<b>Special tyres</b>	By arrangement with the manufacturer



## Steering

<b>Design</b>	"Load-sensing" swash plate type variable flow pump with pressure cut-off and flow control. Central pivot with two double-acting steering cylinders
<b>Angle of articulation</b>	40° to each side
<b>Emergency steering</b>	Electro-hydraulic emergency steering system, optional



## Attachment Hydraulics

	L 524	L 538
<b>Design</b>	"Load-sensing" swash plate type variable flow pump with output and flow control, and pressure cut-off in the control block	
<b>Cooling</b>	Hydraulic oil cooling using thermostatically controlled fan and oil cooler	
<b>Filtration</b>	Return line filter in the hydraulic reservoir	
<b>Control</b>	Liebherr control lever with hydraulic servo control	
<b>Lift circuit</b>	Lifting, neutral, lowering Float position controlled by Liebherr control lever with detent	
<b>Tilt circuit</b>	Tilt back, neutral, dump Automatic bucket return to dig as standard	
<b>Max. flow</b>	l/min. 102	170
<b>Max. pressure</b>	bar 315	350



## Attachment

	L 524	L 538
<b>Geometry variants</b>		
Optional	Powerfull Z-bar linkage with tilt cylinder and steel cross-tube	Parallel linkage with two tilt cylinders and steel cross-tube
<b>Bearings</b>	Sealed	
<b>Cycle time at nominal load</b>	ZK	PK
Lifting	s 6.6	6.6
Dumping	s 1.8	3.5
Lowering (empty)	s 4.0	4.0



## Operator's Cab

<b>Design</b>	Elastic mounted, noise-proof cab ROPS roll over protection per EN ISO 3471 / EN 474-1 FOPS falling objects protection per EN ISO 3449 / EN 474-1, Cat. II. Operator's door with 105° opening angle, ventilation opening on the right hand side, front windscreen made of laminated safety glass, green tinted as standard, side panels with single-pane safety glass, grey tinted, heated rear window. Continuously adjustable steering column and joystick control as standard
<b>Liebherr operator's seat</b>	6 way adjustable, vibration-damped operator's seat "Standard" (mechanically sprung, adjustable to operator's weight)
<b>Cab heating and ventilation</b>	4-level air control, cooling water heating, mechanical controlled heating and air conditioning system as standard



## Sound Level

	L 524	L 538
<b>Sound pressure level to ISO 6396</b>		
L <sub>pA</sub> (inside cab)	dB(A) 69	69
<b>Sound power level to 2000/14/EC</b>		
L <sub>WA</sub> (surround noise)	dB(A) 102	103



## Capacities

	L 524	L 538
<b>Fuel tank</b>	l 225	225
<b>Engine oil (inclusive filter change)</b>	l 14.7	14.7
<b>Transmission</b>	l 3.8	3.8
<b>Coolant</b>	l 36	36
<b>Front axle</b>	l 16.3/2.6	16.3/2.6
<b>Rear axle</b>	l 15/2.6	15/2.6
<b>Hydraulic tank</b>	l 110	110
<b>Hydraulic system, total</b>	l 170	180

# Dimensions

## Z-bar Linkage

L 524 / L 538

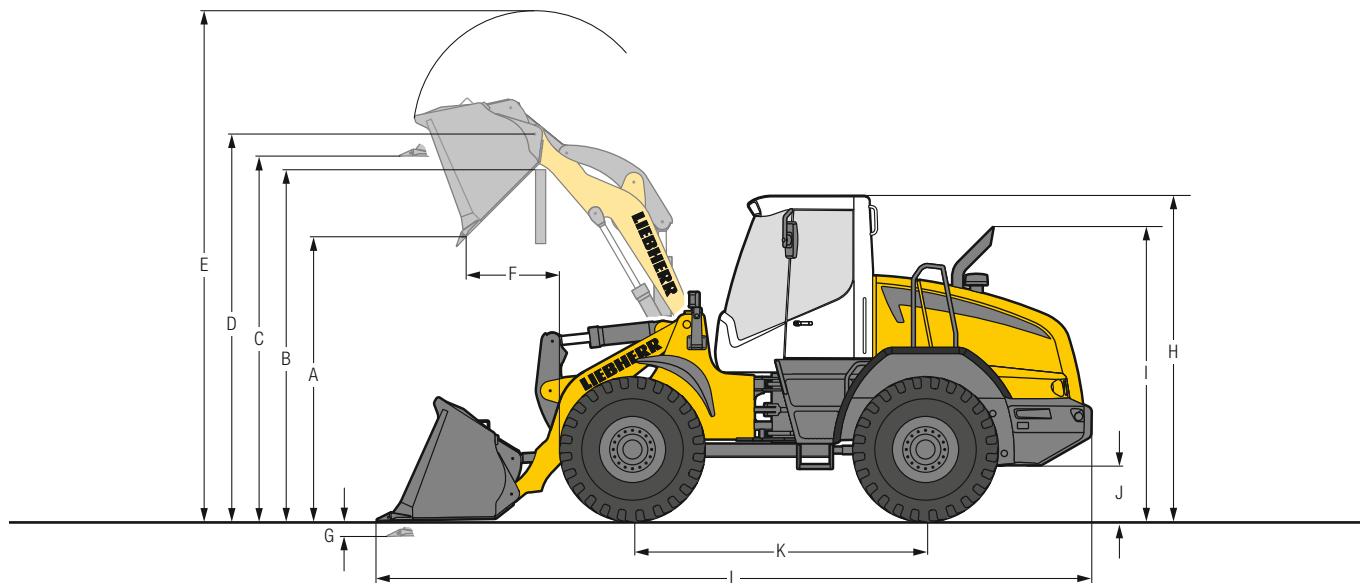

### Excavation Bucket

	L 524		L 538	
	ZK	ZK-QC	ZK	ZK-QC
<b>Geometry</b>				
<b>Cutting tools</b>	T	T	T	T
<b>Lift arm length</b>	mm 2,400	2,400	2,500	2,500
<b>Bucket capacity according to ISO 7546**</b>	m <sup>3</sup> 2.0	1.7	2.5	2.2
<b>Specific material density</b>	t/m <sup>3</sup> 1.8	1.8	1.8	1.8
<b>Bucket width</b>	mm 2,500	2,500	2,500	2,500
<b>A Dumping height at max. lift height and 45° discharge</b>	mm 2,870	2,765	2,900	2,845
<b>B Dump-over height</b>	mm 3,335	3,320	3,480	3,475
<b>C Max. height of bucket bottom</b>	mm 3,530	3,530	3,680	3,680
<b>D Max. height of bucket pivot point</b>	mm 3,775	3,775	3,930	3,930
<b>E Max. operating height</b>	mm 4,860	4,915	5,170	5,260
<b>F Reach at max. lift height and 45° discharge</b>	mm 850	900	960	1,005
<b>G Digging depth</b>	mm 80	80	80	80
<b>H Height above operator's cab</b>	mm 3,200	3,200	3,250	3,250
<b>I Height above exhaust</b>	mm 2,860	2,860	2,910	2,910
<b>J Ground clearance</b>	mm 460	460	490	490
<b>K Wheelbase</b>	mm 2,850	2,850	2,975	2,975
<b>L Overall length</b>	mm 6,820	6,935	7,150	7,225
<b>Turning circle radius over outside bucket edge</b>	mm 5,690	5,720	5,840	5,870
<b>Turning circle radius over tyres</b>	mm 5,170	5,170	5,350	5,350
<b>Width over tyres</b>	mm 2,460	2,460	2,470	2,470
<b>Breakout force (SAE)</b>	kN 91	85	117	114
<b>Tipping load, straight*</b>	kg 8,500	7,900	10,700	10,500
<b>Tipping load, fully articulated*</b>	kg 7,500	7,000	9,500	9,300
<b>Operating weight*</b>	kg 10,400	10,800	12,800	13,000
<b>Tyre size</b>	17.5R25 L3		20.5R25 L3	

\* The figures shown here are valid with tyres above (optional tyres will change the vertical dimensions), includes all lubricants, a full fuel tank, the ROPS/FOPS cab and the operator. Different tyres and optional equipment will change the operating weight and tipping load. (Tipping load, fully articulated according to ISO 14397-1)

\*\* Actual bucket capacity may be approx. 10% larger than the calculation according to ISO 7546 standard. The degree to which the bucket can be filled depends on the material – see page 22.

ZK = Z-bar linkage

ZK-QC = Z-bar linkage incl. quick coupler

T = Welded-on tooth holder with add-on teeth

# Attachment

## Light Material Bucket

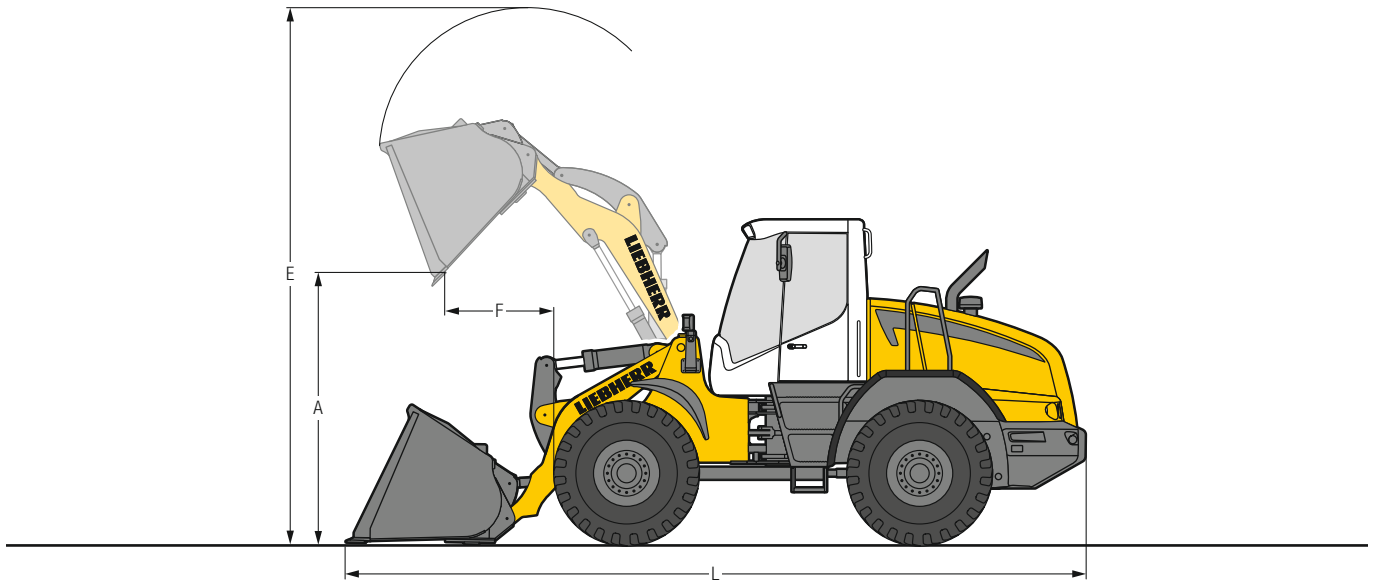

### Light Material Bucket



		L 524				L 538	
		ZK	ZK	ZK	ZK-QC	ZK	ZK-QC
<b>Geometry</b>		ZK	ZK	ZK	ZK-QC	ZK	ZK-QC
<b>Cutting tools</b>		BOCE	BOCE	BOCE	BOCE	BOCE	BOCE
<b>Bucket capacity</b>	m <sup>3</sup>	2.4	3.0	4.0	4.0	3.5	4.0
<b>Specific material density</b>	t/m <sup>3</sup>	1.0	0.8	0.5	0.5	1.0	0.8
<b>Bucket width</b>		mm	2,500	2,500	2,700	2,700	2,700
<b>A Dumping height at max. lift height</b>	mm	2,755	2,640	2,490	2,370	2,730	2,715
<b>E Max. operating height</b>	mm	5,025	5,160	5,300	5,430	5,360	5,440
<b>F Reach at maximum lift height</b>	mm	990	1,110	1,260	1,300	1,140	1,300
<b>L Overall length</b>		mm	7,345	7,130	7,340	7,410	7,360
<b>Tipping load, straight*</b>		kg	8,450	8,260	7,970	7,370	10,420
<b>Tipping load, fully articulated*</b>		kg	7,450	7,290	7,040	6,510	9,190
<b>Operating weight*</b>		kg	10,850	10,980	11,105	11,290	13,180
<b>Tyre size</b>		17.5R25 L3				20.5R25 L3	

\* The figures shown here are valid with tyres above (optional tyres will change the vertical dimensions), includes all lubricants, a full fuel tank, the ROPS/FOPS cab and the operator. Different tyres and optional equipment will change the operating weight and tipping load. (Tipping load, fully articulated according to ISO 14397-1)

ZK = Z-bar linkage

ZK-QC = Z-bar linkage incl. quick coupler

BOCE = Bolt-on cutting edge

# Dimensions

## Parallel Linkage

L 524 / L 538

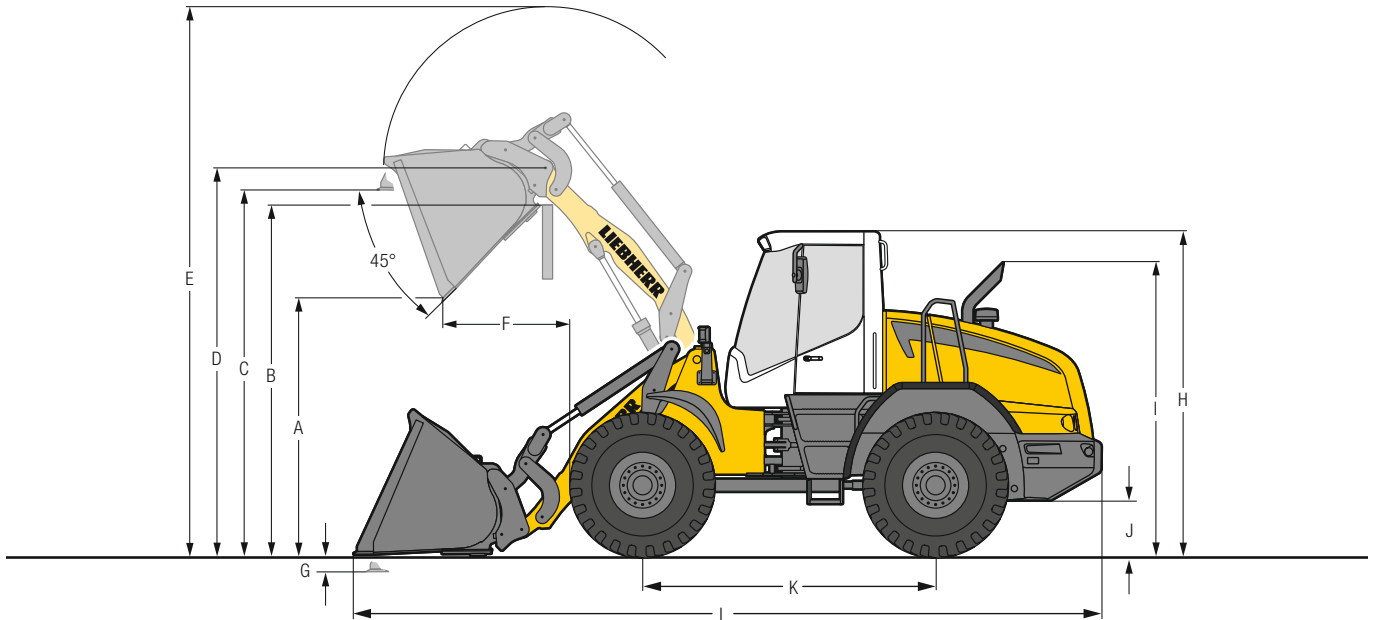

### Light Material Bucket

	L 524		L 538	
	PK-QC	PK-QC	PK-QC	PK-QC
<b>Geometry</b>	PK-QC	PK-QC	PK-QC	PK-QC
<b>Cutting tools</b>	BOCE	BOCE	BOCE	BOCE
<b>Lift arm length</b>	mm	2,500	2,500	2,500
<b>Bucket capacity according to ISO 7546**</b>	m <sup>3</sup>	3.0	5.5	4.0
<b>Specific material density</b>	t/m <sup>3</sup>	1.0	0.5	1.0
<b>Bucket width</b>	mm	2,750	2,750	2,700
<b>A Dumping height at max. lift height and 45° discharge</b>	mm	2,630	2,230	2,520
<b>B Dump-over height</b>	mm	3,380	3,380	3,430
<b>C Max. height of bucket bottom</b>	mm	3,595	3,595	3,645
<b>D Max. height of bucket pivot point</b>	mm	3,835	3,835	3,890
<b>E Max. operating height</b>	mm	5,290	5,670	5,460
<b>F Reach at max. lift height and 45° discharge</b>	mm	1,220	1,630	1,300
<b>G Digging depth</b>	mm	55	55	35
<b>H Height above operator's cab</b>	mm	3,200	3,200	3,250
<b>I Height above exhaust</b>	mm	2,860	2,860	2,910
<b>J Ground clearance</b>	mm	460	460	490
<b>K Wheelbase</b>	mm	2,850	2,850	2,975
<b>L Overall length</b>	mm	7,355	7,930	7,765
<b>Turning circle radius over outside bucket edge</b>	mm	5,765	5,930	6,070
<b>Turning circle radius over tyres</b>	mm	5,170	5,170	5,350
<b>Width over tyres</b>	mm	2,460	2,460	2,470
<b>Breakout force (SAE)</b>	kN	63		87
<b>Tipping load, straight*</b>	kg	7,920	7,330	9,900
<b>Tipping load, fully articulated*</b>	kg	6,980	6,470	8,730
<b>Operating weight*</b>	kg	11,800	12,200	13,600
<b>Tyre sizes</b>		17.5R25 L3		20.5R25 L3

\* The figures shown here are valid with tyres above (optional tyres will change the vertical dimensions), includes all lubricants, a full fuel tank, the ROPS/FOPS cab and the operator. Different tyres and optional equipment will change the operating weight and tipping load. (Tipping load, fully articulated according to ISO 14397-1)

\*\* Actual bucket capacity may be approx. 10% larger than the calculation according to ISO 7546 standard. The degree to which the bucket can be filled depends on the material – see page 22.

PK-QC = Parallel linkage incl. quick coupler

BOCE = Bolt-on cutting edge

# Attachment

## Fork Carrier and Fork

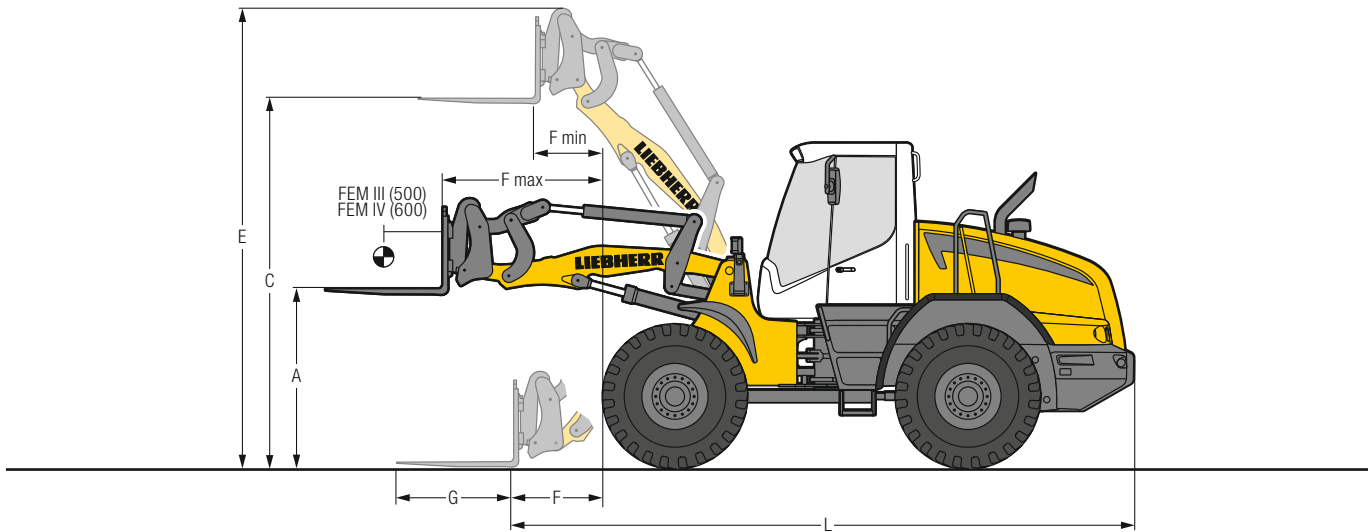

### FEM III Fork Carrier and Fork

		L 524		L 538		
Geometry		ZK-QC	PK-QC	ZK-QC	PK-QC	
<b>A</b>	Lifting height at max. reach	mm	1,690	1,690	1,781	1,739
<b>C</b>	Max. lifting height	mm	3,580	3,645	3,738	3,697
<b>E</b>	Max. operating height	mm	4,510	4,560	4,662	4,612
<b>F</b>	Reach at loading position	mm	975	1,110	939	975
<b>F max.</b>	Max. reach	mm	1,625	1,720	1,635	1,635
<b>F min.</b>	Reach at max. lifting height	mm	695	780	694	695
<b>G</b>	Fork length	mm	1,200	1,200	1,200	1,200
<b>L</b>	Length – basic machine	mm	6,190	6,325	6,350	6,390
	Tipping load, straight *	kg	6,000	6,480	7,880	8,150
	Tipping load, fully articulated *	kg	5,300	5,700	6,940	7,200
	Recommended payload for uneven ground = 60% of tipping load, articulated <sup>1)</sup>	kg	3,180	3,420	4,150	4,320
	Recommended payload for smooth surfaces = 80% of tipping load, articulated <sup>1)</sup>	kg	4,010 <sup>3)</sup>	4,580	5,000 <sup>2)</sup>	5,000 <sup>3)</sup>
	Operating weight*	kg	10,600	11,260	12,700	12,900
	Tyre size		17.5R25 L3		20.5R25 L3	

\* The figures shown here are valid with tyres above (optional tyres will change the vertical dimensions), includes all lubricants, a full fuel tank, the ROPS/FOPS cab and the operator. Different tyres and optional equipment will change the operating weight and tipping load. (Tipping load, fully articulated according to ISO 14397-1)

<sup>1)</sup> According to EN 474-3

<sup>2)</sup> Load capacity for the fork carrier and forks is limited to 5,000 kg

<sup>3)</sup> Payload on forks is limited by tilt cylinder

ZK-QC = Z-bar linkage incl. quick coupler

PK-QC = Parallel linkage incl. quick coupler

# Bucket Selection

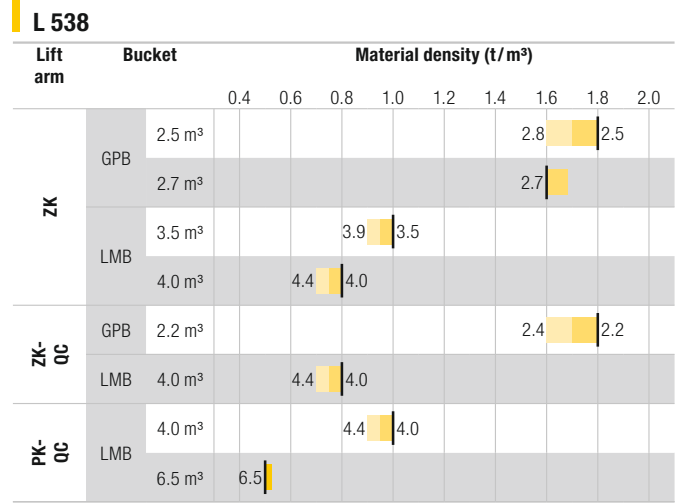
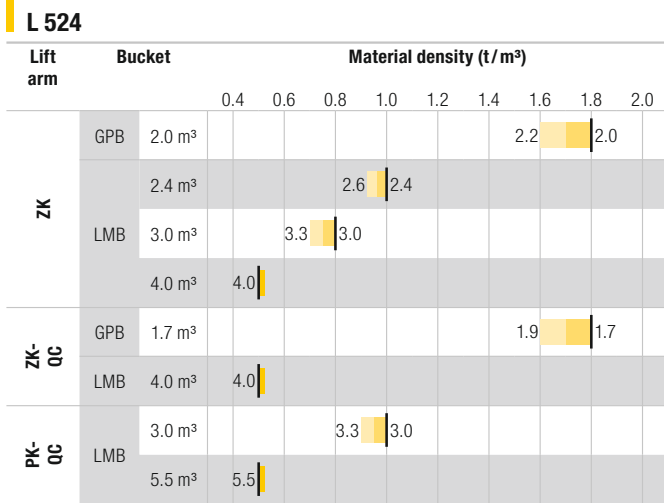

### Lift Arm

<b>ZK</b>	Z-bar linkage, standard lift arm length
<b>ZK-QC</b>	Z-bar linkage, with quick coupler, standard lift arm length
<b>PK-QC</b>	Parallel linkage with quick coupler, standard lift arm length

### Bucket

<b>GPB</b>	General purpose bucket (Excavation bucket)
<b>LMB</b>	Light material bucket

### Bulk Material Densities and Bucket Filling Factors

		t/m³	%			t/m³	%			t/m³	%
<b>Gravel</b>	moist	1.9	105	<b>Earth</b>	dry	1.3	115	<b>Glass waste</b>	broken	1.4	100
	dry	1.6	105		wet excavated	1.6	110		solid	1.0	100
	crushed stone	1.5	100	<b>Topsoil</b>		1.1	110	<b>Compost</b>	dry	0.8	105
<b>Sand</b>	dry	1.5	105	<b>Basalt</b>		1.95	100	wet	1.0	110	
	wet	1.9	110	<b>Granite</b>		1.8	95	<b>Wood chips / Saw dust</b>		0.5	110
<b>Gravel and Sand</b>	dry	1.7	105	<b>Sandstone</b>		1.6	100	<b>Paper</b>	shredded/loose	0.6	110
	wet	2.0	100	<b>Slate</b>		1.75	100	recovered paper / cardboard	1.0	110	
<b>Sand / Clay</b>		1.6	110	<b>Bauxite</b>		1.4	100	<b>Coal</b>	heavy material density	1.2	110
<b>Clay</b>	natural	1.6	110	<b>Limestone</b>		1.6	100	light material density	0.9	110	
	dry	1.4	110	<b>Gypsum</b>	broken	1.8	100	<b>Waste</b>	domestic waste	0.5	100
<b>Clay / Gravel</b>	dry	1.4	110	<b>Coke</b>		0.5	110	bulky waste	1.0	100	
	wet	1.6	100	<b>Slag</b>	broken	1.8	100				

# Technical Data



## Engine

	L 550	L 566	L 580
<b>Diesel engine</b>	6068HFL84	Stage II: 6090HFL75	Stage II: 6090HFL75 Stage IIIA: 6090HFL85
Design	Water-cooled, turbo charged, intercooled		
Cylinder inline	6	6	6
Fuel injection process	Electronic Common Rail high-pressure injection		
Max. gross output to ISO 3046 and SAE J1995	kW/HP 147/200 at RPM 1,600	209/284 1,600	209/284 1,600
Max. net output to ISO 9249 and SAE J1349	kW/HP 146/199 at RPM 2,000	206/280 1,600	206/280 1,600
Rated output to ISO 14396	kW/HP 140/190 at RPM 2,400	200/272 2,000	200/272 2,000
Max. net torque to ISO 9249 and SAE J1349	Nm 848 at RPM 1,300	1,300 1,500	1,300 1,500
Displacement	litres 6.8	9.0	9.0
Bore/Stroke	mm 106/127	118.4/136	118.4/136
<b>Air cleaner system</b>	Dry air filter with main and safety element, pre-cleaner, service indicator		
<b>Electrical system</b>			
Operating voltage	V 24	24	24
Battery	Ah 2 x 140	2 x 180	2 x 180
Alternator	V/A 28/100	28/100	28/100
Starter	V/kW 24/7.8	24/7.8	24/7.8

L 550: Available for exhaust emission limits of stage II, China III, Bharat stage III (India).

L 566/L 580: Availability of models with exhaust standards of stage II or stage IIIA depends on emission regulations in respective countries.



## Driveline

### Continuous hydrostatic driveline

**Design** Swash plate type variable flow pump and two variable axial piston motors in closed loop circuit and axle transfer case. Direction of travel is reversed by changing the flow-direction of the variable-displacement pump

**Filtration** Suction return line filter for closed circuit

**Control** By travel and inching pedal. The inching pedal makes it possible to control the tractive and thrust forces steplessly at full engine speed. The Liebherr control lever is used to control forward and reverse travel

### Travel speed range

#### L 550:

Speed range 1 \_\_\_\_\_ 0 – 4 km/h

Speed range A1 – 2 \_\_\_\_\_ 0 – 15 km/h

Speed range A1 – 3 \_\_\_\_\_ 0 – 40 km/h forward and reverse

#### L 566/L 580:

Speed range 1 \_\_\_\_\_ 0 – 10 km/h

Speed range 2 and A2 \_\_\_\_\_ 0 – 20 km/h

Speed range A3 \_\_\_\_\_ 0 – 40 km/h forward and reverse

Speeds quoted apply with the tyres indicated as standard on loader model.

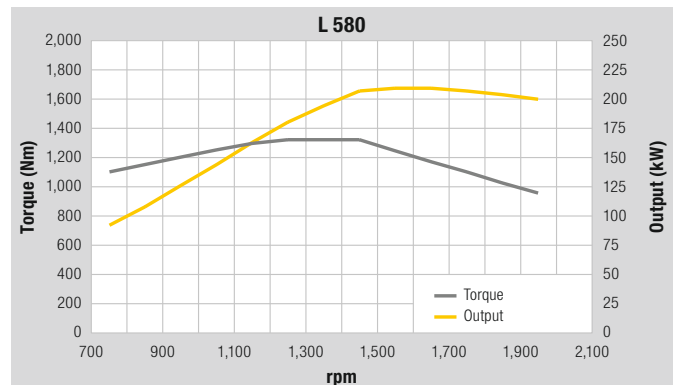
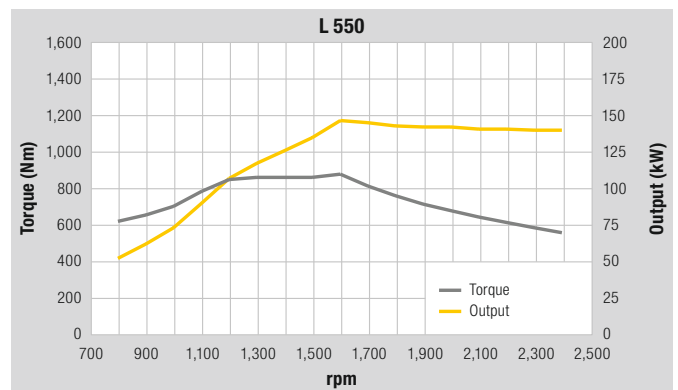
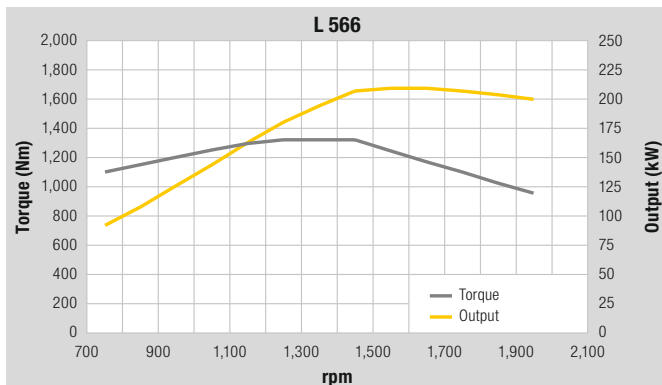

# Technical Data

## Axles

	L 550	L 566	L 580
<b>Four-wheel drive</b>			
<b>Front axle</b>	Fixed		
<b>Rear axle</b>	Centre pivot, with 13° oscillating angle to each side		
Height of obstacles which can be driven over	mm 460	490	490
	with all four wheels remaining in contact with the ground		
<b>Differentials</b>	Automatic limited-slip differentials		
<b>Reduction gear</b>	Planetary final drive in wheel hubs		
<b>Track width</b>	2,000 mm with all types of tyres (L 550) 2,230 mm with all types of tyres (L 566, L 580)		

## Brakes

<b>Wear-free service brake</b>	Self-locking of the hydrostatic driveline (acting on all four wheels) and additional pumpaccumulator brake system with wet multi-disc brakes (two separate brake circuits)
<b>Parking brake</b>	Electro-hydraulically actuated spring-loaded disc brake system on the transmission

The braking system meets the requirements of the ISO 3450.

## Tyres

<b>Standard size L 550</b>	23.5R25 L3
<b>Standard size L 566</b>	26.5R25 L3
<b>Standard size L 580</b>	26.5R25 L3
<b>Special tyres</b>	By arrangement with the manufacturer

## Steering

<b>Design</b>	"Load-sensing" swash plate type variable flow pump with pressure cut-off and flow control. Central pivot with two double-acting, damped steering cylinders
<b>Angle of articulation</b>	40° to each side
<b>Emergency steering</b>	Electro-hydraulic emergency steering system, optional

## Attachment Hydraulics

	L 550	L 566	L 580
<b>Design</b>	"Load-sensing" swash plate type variable flow pump with output and flow control, and pressure cut-off in the control block		
<b>Cooling</b>	Hydraulic oil cooling using thermostatically controlled fan and oil cooler		
<b>Filtration</b>	Return line filter in the hydraulic reservoir		
<b>Control</b>	Liebherr control lever with hydraulic servo control		
<b>Lift circuit</b>	Lifting, neutral, lowering Float position controlled by Liebherr control lever with detent		
<b>Tilt circuit</b>	Tilt back, neutral, dump Automatic bucket return to dig as standard		
<b>Max. flow</b>	l/min. 234	290	290
<b>Max. pressure</b>	bar 360	380	380

## Attachment

	L 550	L 566	L 580			
<b>Geometry variants</b>						
Optional	Powerful Z-bar linkage with tilt cylinder and cast steel cross-tube Industrial lift arm with tilt cylinder, hydraulic quick coupler as standard					
<b>Bearings</b>	Sealed					
<b>Cycle time at nominal load</b>	ZK	IND	ZK	IND	ZK	IND
Lifting	s 5.5	5.5	5.5	5.5	5.5	5.5
Dumping	s 2.3	3.5	2.0	3.0	2.0	3.2
Lowering (empty)	s 2.7	2.7	3.5	3.5	3.5	3.5

## Operator's Cab

<b>Design</b>	Elastic mounted, noise-proof cab ROPS roll over protection per EN ISO 3471 / EN 474-1 FOPS falling objects protection per EN ISO 3449 / EN 474-1, Cat. II Operator's door with 105° (L 550) / 180° (L 566, L 580) opening angle, ventilation opening on the right hand side, front windscreen made of laminated safety glass, green tinted as standard, side panels with single-pane safety glass, grey tinted, heated rear window. Continuously adjustable steering column and joystick control as standard
<b>Liebherr operator's seat</b>	6 way adjustable, vibration-damped operator's seat "Standard" (mechanically sprung, adjustable to operator's weight)
<b>Cab heating and ventilation</b>	4-level air control, cooling water heating, mechanical controlled heating and air conditioning system as standard

## Sound Level

	L 550	L 566	L 580
<b>Sound pressure level to ISO 6396</b>			
L <sub>pA</sub> (inside cab)	dB(A) 75	71	71
<b>Sound power level to 2000/14/EC</b>			
L <sub>WA</sub> (surround noise)	dB(A) 105	106	106

## Capacities

	L 550	L 566	L 580
<b>Fuel tank</b>	l 300	400	400
<b>Engine oil (inclusive filter change)</b>	l 19.5	34	34
<b>Pump distribution gearbox</b>	l	2.5	2.5
<b>Transmission</b>	l 4.1	11.5	11.5
<b>Coolant</b>	l 38	42	42
<b>Front axle</b>	l 35	42	42
<b>Rear axle</b>	l 35	42	42
<b>Hydraulic tank</b>	l 135	135	135
<b>Hydraulic system, total</b>	l 240	290	290



# Dimensions

## Z-bar Linkage

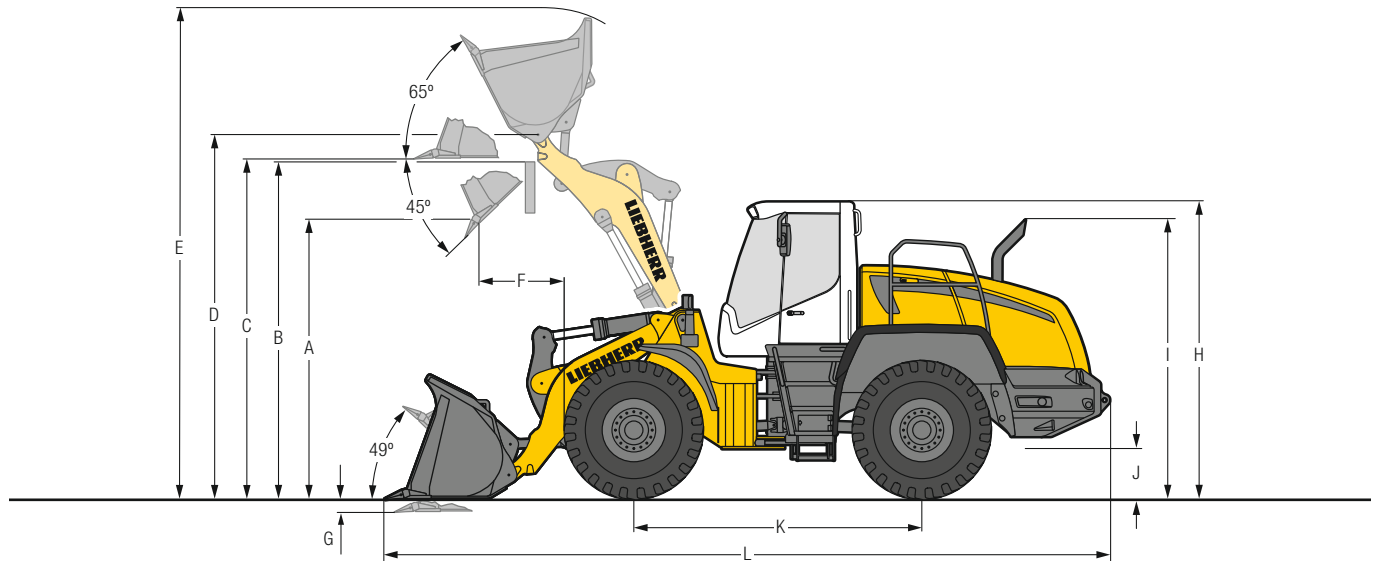

L 550 / L 566 / L 580

### Excavation Bucket



	L 550			L 566			L 580			
	STD	STD	HL	STD	STD	HL	STD	STD	HL	
<b>Geometry</b>	ZK	ZK	ZK	ZK	ZK	ZK	ZK	ZK	ZK	
<b>Cutting tools</b>	T	T	T	T	T	T	T	T	T	
<b>Lift arm length</b>	mm	2,750	2,750	3,050	2,920	2,920	3,250	3,050	3,050	3,250
<b>Bucket capacity according to ISO 7546**</b>	m <sup>3</sup>	3.2	3.6	3.2	4.0	4.5	4.0	5.0	5.5	5.0
<b>Specific material density</b>	t/m <sup>3</sup>	1.8	1.6	1.6	1.8	1.6	1.6	1.8	1.6	1.6
<b>Bucket width</b>	mm	2,700	2,700	2,700	3,000	3,000	3,000	3,300	3,300	3,300
<b>A Dumping height at max. lift height and 45° discharge</b>	mm	3,140	3,050	3,590	3,240	3,185	3,665	3,320	3,250	3,530
<b>B Dump-over height</b>	mm	3,700	3,700	4,100	3,900	3,900	4,300	4,100	4,100	4,300
<b>C Max. height of bucket bottom</b>	mm	3,920	3,920	4,330	4,050	4,050	4,470	4,270	4,270	4,470
<b>D Max. height of bucket pivot point</b>	mm	4,180	4,180	4,600	4,360	4,360	4,780	4,580	4,580	4,780
<b>E Max. operating height</b>	mm	5,660	5,750	6,100	5,870	5,960	6,285	6,340	6,420	6,540
<b>F Reach at max. lift height and 45° discharge</b>	mm	1,020	1,100	960	1,180	1,240	1,070	1,150	1,220	1,215
<b>G Digging depth</b>	mm	85	85	130	100	100	140	100	100	140
<b>H Height above operator's cab</b>	mm	3,360	3,360	3,360	3,590	3,590	3,590	3,590	3,590	3,590
<b>I Height above exhaust</b>	mm	3,015	3,015	3,015	3,000	3,000	3,000	3,000	3,000	3,000
<b>J Ground clearance</b>	mm	490	490	490	535	535	535	535	535	535
<b>K Wheelbase</b>	mm	3,305	3,305	3,305	3,780	3,780	3,780	3,900	3,900	3,900
<b>L Overall length</b>	mm	8,300	8,400	8,720	9,260	9,340	9,715	9,645	9,745	9,915
<b>Turning circle radius over outside bucket edge</b>	mm	6,480	6,540	6,700	7,580	7,600	7,765	7,910	7,940	8,025
<b>Turning circle radius over tyres</b>	mm	5,885	5,885	5,885	6,995	6,995	6,995	7,150	7,150	7,150
<b>Width over tyres</b>	mm	2,650	2,650	2,650	2,960	2,960	2,960	2,960	2,960	2,960
<b>Breakout force (SAE)</b>	kN	140	130	120	200	190	175	190	175	175
<b>Tipping load, straight*</b>	kg	14,150	13,950	12,240	18,000	17,800	15,015	20,750	20,550	19,020
<b>Tipping load, fully articulated*</b>	kg	12,350	12,150	10,800	15,550	15,350	13,245	18,000	17,800	16,845
<b>Operating weight*</b>	kg	17,350	17,450	17,440	23,100	23,200	23,620	24,720	24,870	25,540
<b>Tyre sizes</b>		23.5R25 L3			26.5R25 L3			26.5R25 L3		

\* The figures shown here are valid with tyres above (optional tyres will change the vertical dimensions), includes all lubricants, a full fuel tank, the ROPS/FOPS cab and the operator. Different tyres and optional equipment will change the operating weight and tipping load. (Tipping load, fully articulated according to ISO 14397-1)

\*\* Actual bucket capacity may be approx. 10% larger than the calculation according to ISO 7546 standard. The degree to which the bucket can be filled depends on the material – see page 29.

STD = Standard lift arm length

HL = High Lift

ZK = Z-bar linkage

T = Welded-on tooth holder with add-on teeth

# Dimensions

## Industrial Lift Arm

L 550 / L 566 / L 580

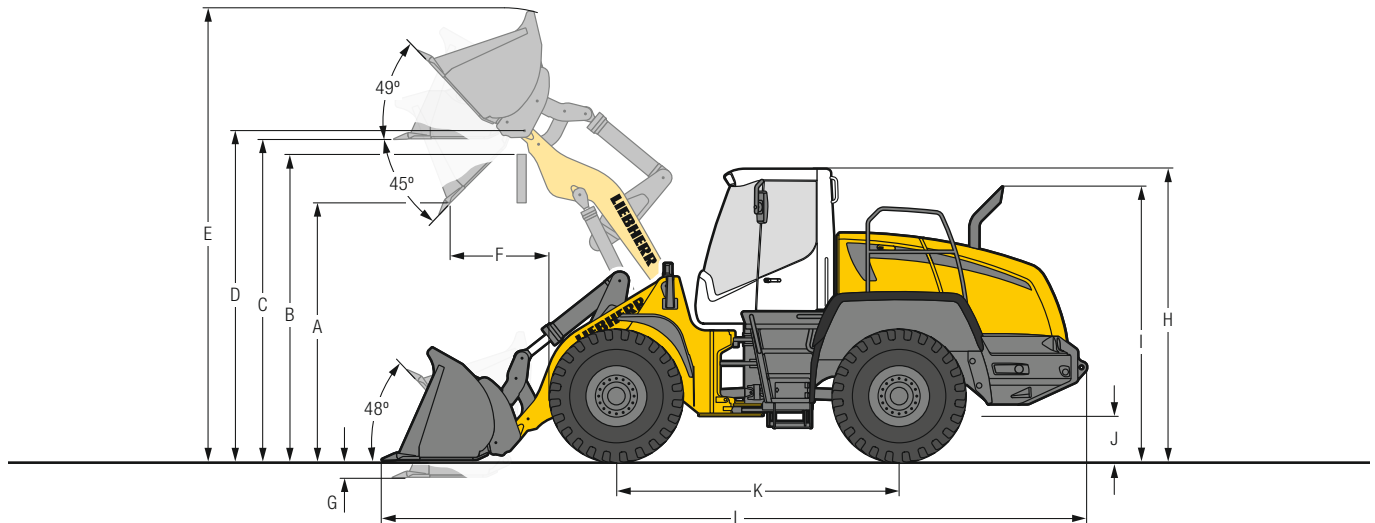

### Excavation Bucket



		L 550	L 566	L 580
Geometry		IND-QC	IND-QC	IND-QC
Cutting tools		T	T	T
Lift arm length	mm	2,600	2,900	2,900
Bucket capacity according to ISO 7546**	m <sup>3</sup>	3.0	3.5	4.5
Specific material density	t/m <sup>3</sup>	1.8	1.8	1.8
Bucket width	mm	2,700	3,000	3,000
A Dumping height at max. lift height and 45° discharge	mm	2,880	3,210	3,070
B Dump-over height	mm	3,500	3,900	3,900
C Max. height of bucket bottom	mm	3,795	4,145	4,145
D Max. height of bucket pivot point	mm	4,075	4,490	4,490
E Max. operating height	mm	5,580	6,045	6,265
F Reach at max. lift height and 45° discharge	mm	1,135	1,270	1,290
G Digging depth	mm	80	100	100
H Height above operator's cab	mm	3,360	3,590	3,590
I Height above exhaust	mm	3,015	3,000	3,000
J Ground clearance	mm	490	535	535
K Wheelbase	mm	3,305	3,780	3,900
L Overall length	mm	8,350	9,345	9,545
Turning circle radius over outside bucket edge	mm	6,500	7,575	7,720
Turning circle radius over tyres	mm	5,885	6,995	7,150
Width over tyres	mm	2,650	2,960	2,960
Breakout force (SAE)	kN	125	200	200
Tipping load, straight*	kg	12,700	15,650	19,800
Tipping load, fully articulated*	kg	10,950	13,400	17,100
Operating weight*	kg	17,950	24,150	25,750
Tyre sizes		23.5R25 L3	26.5R25 L3	26.5R25 L3

\* The figures shown here are valid with tyres above (optional tyres will change the vertical dimensions), includes all lubricants, a full fuel tank, the ROPS/FOPS cab and the operator. Different tyres and optional equipment will change the operating weight and tipping load. (Tipping load, fully articulated according to ISO 14397-1)

\*\* Actual bucket capacity may be approx. 10 % larger than the calculation according to ISO 7546 standard. The degree to which the bucket can be filled depends on the material – see page 29.

IND-QC = Industrial lift arm with parallel guidance incl. quick coupler

T = Welded-on tooth holder with add-on teeth

# Attachment

## Light Material Bucket

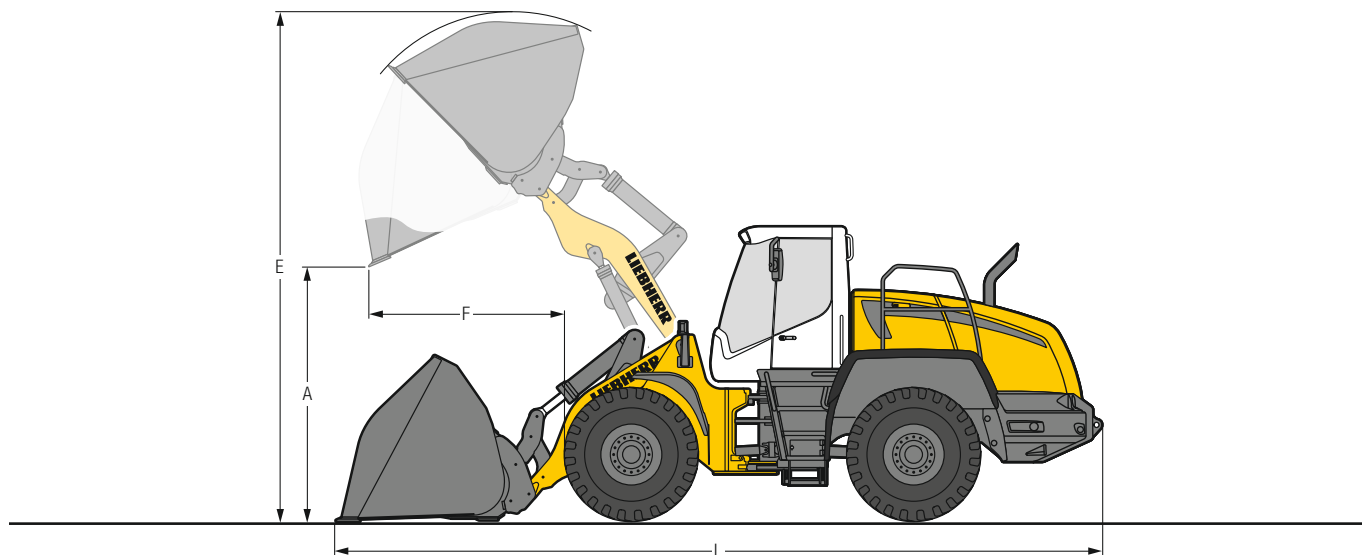

L 550 / L 566 / L 580

### Light Material Bucket



		L 550		L 566		L 580	
<b>Geometry</b>		IND-QC	IND-QC	IND-QC	IND-QC	IND-QC	IND-QC
<b>Cutting tools</b>		BOCE	BOCE	BOCE	BOCE	BOCE	BOCE
<b>Bucket capacity</b>	<b>m<sup>3</sup></b>	5.0	9.0	6.5	12.0	7.5	14.0
<b>Specific material density</b>	<b>t/m<sup>3</sup></b>	1.0	0.5	1.0	0.45	1.0	0.45
<b>Bucket width</b>	<b>mm</b>	2,950	3,400	3,200	3,700	3,400	4,000
<b>A Dumping height at max. lift height</b>	<b>mm</b>	2,550	2,340	2,885	2,620	2,810	2,480
<b>E Max. operating height</b>	<b>mm</b>	5,900	6,110	6,470	6,700	6,580	6,800
<b>F Reach at maximum lift height</b>	<b>mm</b>	1,450	1,705	1,485	1,860	1,550	1,950
<b>L Overall length</b>	<b>mm</b>	8,600	8,970	9,620	10,100	9,715	10,200
<b>Tipping load, straight*</b>	<b>kg</b>	11,950	11,450	14,600	13,850	18,700	16,450
<b>Tipping load, fully articulated*</b>	<b>kg</b>	10,300	9,750	12,400	12,100	16,000	14,400
<b>Operating weight*</b>	<b>kg</b>	18,250	18,950	24,700	25,650	26,400	27,300
<b>Tyre size</b>		23.5R25 L3		26.5R25 L3		26.5R25 L3	

\* The figures shown here are valid with tyres above (optional tyres will change the vertical dimensions), includes all lubricants, a full fuel tank, the ROPS/FOPS cab and the operator. Different tyres and optional equipment will change the operating weight and tipping load. (Tipping load, fully articulated according to ISO 14397-1)

IND-QC = Industrial lift arm with parallel guidance incl. quick coupler

BOCE = Bolt-on cutting edge

# Attachment

## Log Grapple

L 550 / L 566 / L 580

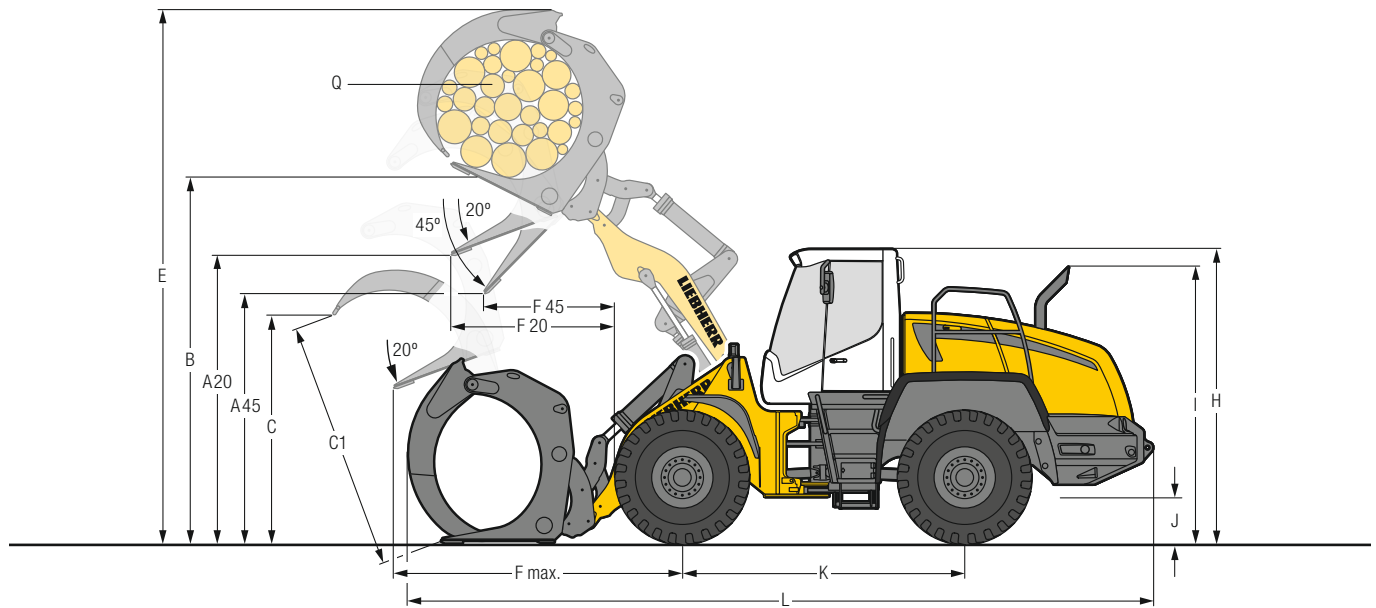

### Log Grapple

		L 550	L 566	L 580
	<b>Geometry</b>	IND-QC	IND-QC	IND-QC
A20	Discharge height at 20°	mm	3,570	3,520
A45	Discharge height at 45°	mm	2,950	2,805
B	Manipulation height	mm	4,530	5,125
C	Max. grapple opening in loading position	mm	2,740	2,930
C1	Max. grapple opening	mm	2,990	3,340
E	Max. height	mm	6,480	7,400
F20	Reach at max. lifting height at 20° discharge	mm	1,890	2,165
F45	Reach at max. lifting height at 45° discharge	mm	1,530	1,625
F max.	Max. reach	mm	2,820	3,110
H	Height above operator's cab	mm	3,360	3,590
I	Height above exhaust	mm	3,015	3,000
J	Ground clearance	mm	490	535
K	Wheelbase	mm	3,305	3,780
L	Overall length	mm	8,700	9,880
	Width over tyres	mm	2,650	2,970
Q	Grapple diameter	m <sup>2</sup>	2.4	3.1
	Grapple width	mm	1,600	1,800
	Payload*	kg	6,400	8,200
	Operating weight*	kg	19,450	25,750
	Tyre size		23.5R25 L3	26.5R25 L3

\* The figures shown here are valid with tyres above (optional tyres will change the vertical dimensions), includes all lubricants, a full fuel tank, the ROPS/FOPS cab and the operator. Different tyres and optional equipment will change the operating weight and payload.

IND-QC = Industrial lift arm with parallel guidance incl. quick coupler

# Bucket Selection

## L 550

Lift arm	Bucket	Material density (t/m <sup>3</sup> )									
		0.4	0.6	0.8	1.0	1.2	1.4	1.6	1.8	2.0	
ZK	GPB 3.2 m <sup>3</sup>									3.5	3.2
	GPB 3.6 m <sup>3</sup>									4.0	3.6
ZK-HL	GPB 3.2 m <sup>3</sup>									3.5	3.2
IND-QC	GPB 3.0 m <sup>3</sup>									3.3	3.0
	LMB 5.0 m <sup>3</sup>									5.5	5.0
	LMB 9.0 m <sup>3</sup>									9.0	

## L 566

Lift arm	Bucket	Material density (t/m <sup>3</sup> )										
		0.4	0.6	0.8	1.0	1.2	1.4	1.6	1.8	2.0		
ZK	GPB 4.0 m <sup>3</sup>										4.4	4.0
	GPB 4.5 m <sup>3</sup>										5.0	4.5
ZK-HL	GPB 4.0 m <sup>3</sup>										4.4	4.0
IND-QC	GPB 3.5 m <sup>3</sup>										3.9	3.5
	LMB 6.5 m <sup>3</sup>										7.2	6.5
	LMB 12.0 m <sup>3</sup>										12.0	

## L 580

Lift arm	Bucket	Material density (t/m <sup>3</sup> )										
		0.4	0.6	0.8	1.0	1.2	1.4	1.6	1.8	2.0		
ZK	GPB 5.0 m <sup>3</sup>										5.5	5.0
	GPB 5.5 m <sup>3</sup>										6.0	5.5
ZK-HL	GPB 5.0 m <sup>3</sup>										5.5	5.0
IND-QC	GPB 4.5 m <sup>3</sup>										5.0	4.5
	LMB 7.5 m <sup>3</sup>										8.3	7.5
	LMB 14.0 m <sup>3</sup>										14.0	

## Bucket Filling Factor

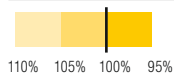

## Lift Arm

<b>ZK</b>	Z-bar linkage, standard lift arm length
<b>ZK-HL</b>	Z-bar linkage, High Lift
<b>IND-QC</b>	Industrial lift arm with quick coupler, standard lift arm length

## Bucket

<b>GPB</b>	General purpose bucket (Excavation bucket)
<b>LMB</b>	Light material bucket

## Bulk Material Densities and Bucket Filling Factors

		t/m <sup>3</sup>	%			t/m <sup>3</sup>	%			t/m <sup>3</sup>	%
<b>Gravel</b>	moist	1.9	105	<b>Earth</b>	dry	1.3	115	<b>Glass waste</b>	broken	1.4	100
	dry	1.6	105		wet excavated	1.6	110		solid	1.0	100
	crushed stone	1.5	100	<b>Topsoil</b>		1.1	110	<b>Compost</b>	dry	0.8	105
<b>Sand</b>	dry	1.5	105	<b>Basalt</b>		1.95	100		wet	1.0	110
	wet	1.9	110	<b>Granite</b>		1.8	95	<b>Wood chips/Saw dust</b>		0.5	110
<b>Gravel and Sand</b>	dry	1.7	105	<b>Sandstone</b>		1.6	100	<b>Paper</b>	shredded/loose	0.6	110
	wet	2.0	100	<b>Slate</b>		1.75	100		recovered paper/cardboard	1.0	110
<b>Sand/Clay</b>		1.6	110	<b>Bauxite</b>		1.4	100	<b>Coal</b>	heavy material density	1.2	110
<b>Clay</b>	natural	1.6	110	<b>Limestone</b>		1.6	100		light material density	0.9	110
	dry	1.4	110	<b>Gypsum</b>	broken	1.8	100	<b>Waste</b>	domestic waste	0.5	100
<b>Clay/Gravel</b>	dry	1.4	110	<b>Coke</b>		0.5	110		bulky waste	1.0	100
	wet	1.6	100	<b>Slag</b>	broken	1.8	100				

# Tipping Load



### What is tipping load?

Load at centre of gravity of working equipment, so that the wheel loader just begins to tip over the front axle. This is the most unfavourable static-load position for the wheel loader. Lifting arms horizontal, wheel loader fully articulated at centre pivot.

### Pay load.

The pay load must not exceed 50% of the tipping load when articulated. This is equivalent to a static stability-margin factor of 2.0.

### Bucket capacity.

The bucket volume is determined from the pay load.

$$\text{Pay load} = \frac{\text{Tipping load, articulated}}{2}$$

$$\text{Bucket capacity} = \frac{\text{Pay load (t)}}{\text{Specific bulk weight of material (t/m}^3\text{)}}$$

# The Liebherr Wheel Loaders

Wheel Loader		L 524	L 538	L 550	L 566	L 580
Tipping load	kg	7,500	9,500	12,350	15,550	18,000
Bucket capacity	m <sup>3</sup>	2.0	2.5	3.2	4.0	5.0
Operating weight	kg	10,400	12,800	17,350	23,100	24,720
Engine output (ISO 14396)	kW/HP	86/117	104/141	140/190	200/272	200/272

06.17

## Environmental Protection Can Help You Earn Money!

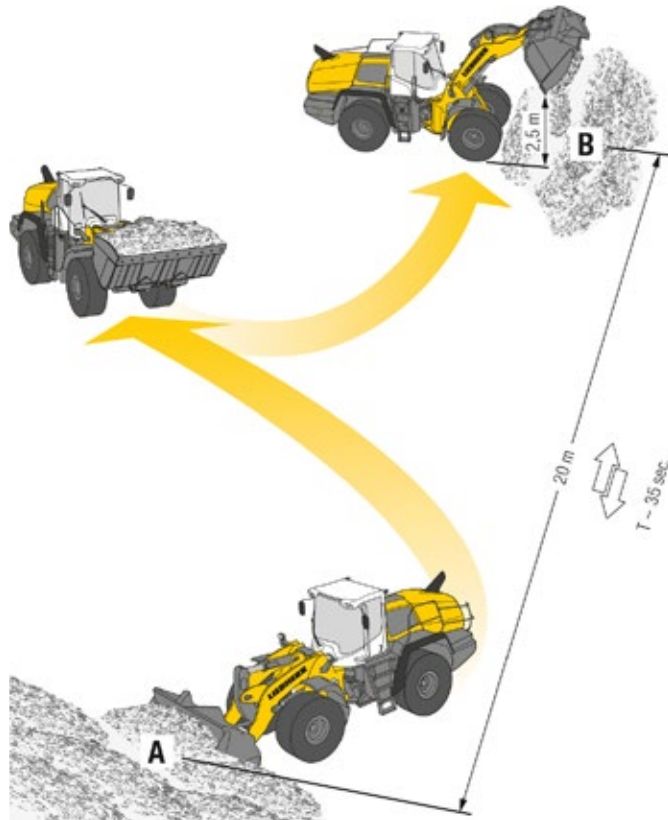

### The Liebherr Standard Consumption Test – easy to reproduce and practical.

The Liebherr Standard Consumption Test determines the number of loading cycles that can be carried out with 5 litres of diesel. The material is taken from pile A and carried over a distance of 20 metres to point B. The time needed for each working cycle should be 35 seconds. Discharge at point B should take place from a height of 2.5 m. The working cycles continue until the 5 litres of diesel in the external measuring tank have been used up. The loader's fuel consumption per operating hour is calculated as follows:

$$\frac{400}{\text{Number of loading cycles}} = \text{Consumption per hour}$$

### Values for the Liebherr Wheel Loaders

	Numbers of working cycles	Litres/ 100 tons	Litres/ hour
L 524: 2.0 m <sup>3</sup>	n = 47	2.9	8.5
L 538: 2.5 m <sup>3</sup>	n = 39	2.9	10.3
L 550: 3.2 m <sup>3</sup>	n = 30	2.9	13.5
L 566: 4.0 m <sup>3</sup>	n = 23	3.0	17.3
L 580: 5.0 m <sup>3</sup>	n = 21	2.6	19.1

# Equipment

 <b>Basic Wheel Loader</b>	L 524	L 538	L 550	L 566	L 580
Crash protection, rear	+	+	+	+	+
Automatic central lubrication system	+	+	+	+	+
Battery main switch (lockable)	•	•	•	•	•
Ride control	+	+	+	+	+
Parking brake	•	•	•	•	•
Fluff trap for radiator	+	+	+	+	+
Speed limiter V <sub>max</sub> adjustable key on the control unit	•	•	•	•	•
Pre-heat system for cold starting	•	•	•	•	•
Rear license panel light	+	+	+	+	+
Combined inching-braking system	•	•	•	•	•
Steel mudguard	•	•	•	•	•
Steel fuel tank	•	•	•	•	•
Fuel pre-filter	•	•	•	•	•
Fuel pre-filter with pre-heating	•	•	•	•	•
Large-mesh radiator	+	+	+	+	+
Cooling water pre-heating 230 V	+	+	+	+	+
Multi-disc limited slip differentials in both axles	•	•	•	•	•
Reversible fan drive	+	+	+	+	+
Headlights rear, single design (on tail flap), halogen	•	•	•	•	•
Auxiliary heater (Additional heating with engine preheating)	+	+	+	+	+
Lockable doors and engine hood	•	•	•	•	•
Chassis protection rear	+	+	+	+	+
Chassis protection front	+	+	+	+	+
Chock	+	+	+	+	+
Air pre-cleaner TOP SPIN	+	+	+	+	+
Toolbox with toolkit	•	•	•	•	•
Towing hitch	•	•	•	•	•

 <b>Equipment</b>	L 524	L 538	L 550	L 566	L 580
Working hydraulics lockout	•	•	•	•	•
Automatic hoist kick-out – adjustable	–	–	+	+	+
Automatic bucket return – adjustable	•	•	•	•	•
Fork carrier and pallet forks	+	+	+	+	+
High-dump bucket	+	+	+	+	+
Log grapple	+	+	+	+	+
High Lift arms	–	–	+	+	+
Industrial lift arm	–	–	+	+	+
Lift arm parallel linkage	+	+	–	–	–
Lift arm Z-bar linkage	•	•	•	•	•
Hydraulic quick coupler	+	+	+	+	+
Tilt cylinder protection	+	+	+	+	+
Loading buckets incl. a range of cutting tools	+	+	+	+	+
Light material bucket	+	+	+	+	+
Load holding valves	+	+	+	+	+
Float position	•	•	•	•	•
3rd hydraulic control circuit	+	+	+	+	+

# Equipment

 <b>Operator's Cab</b>	L 524	L 538	L 550	L 566	L 580
Exterior mirror, tiltable and adjustable	•	•	•	•	•
Operating hour meter (integrated in display unit)	•	•	•	•	•
Storage box	•	•	•	•	•
Operator's seat – air sprung	+	+	+	+	+
Operator seat "Comfort" – air sprung with seat heating	+	+	+	+	+
Operator seat "Standard" – mechanically sprung	•	•	•	•	•
Heater	•	•	•	•	•
Floor mat	•	•	•	•	•
Clothes hook	•	•	•	•	•
Air conditioning system	•	•	•	•	•
Headrest	+	+	+	+	+
Steering column adjustable	•	•	•	•	•
Liebherr control lever – adjustable	•	•	•	•	•
Radio Liebherr "Standard" (SD/USB/AUX)	•	•	•	•	•
Interior rear-view mirror	•	•	•	•	•
Amber beacon swiveling / fixed	+	+	+	+	+
Soundproof ROPS/FOPS cab	•	•	•	•	•
Wipe and wash system	•	•	•	•	•
Headlights rear, single design, halogen	•	•	•	•	•
Headlights rear, double design, halogen	+	+	+	-	-
Headlights rear, double design, LED	-	-	-	+	+
Headlights front, double design, halogen	•	•	•	•	•
Windscreen guard	+	+	+	+	+
Sun visor front	•	•	•	•	•
Power socket 12 V	•	•	•	•	•
Preparation for LIDAT	+	+	+	+	+
Cigarette lighter	•	•	•	•	•

 <b>Safety</b>	L 524	L 538	L 550	L 566	L 580
Country-specific versions	+	+	+	+	+
Emergency steering system	+	+	+	+	+
Back-up alarm acoustic	•	•	•	•	•
Rear space monitoring with camera	+	+	+	+	+

• = Standard  
 + = Option  
 - = not available