



JX SERIES

60 - 95HP RATED POWER



- ▶ **Safe and productive work environment.** Available with or without cab these tractors can be tailored to fit your farming or business operation.
- ▶ **Sitting in comfort.** The fully adjustable seat is readily adapted to each operator preference. In addition, cab versions can be specified with air conditioning.
- ▶ **Practical technology in every aspect.** Controls fall readily to hand and the relevant operating information is clearly displayed allowing new or novice operators to quickly become familiar.
- ▶ **All the power you need.** There are 5 JX models from 60 to 95hp(cv) with a choice of 2 or 4 wheel drive, to ensure there is a tractor with the power and ability to fit your application.

PRACTICAL TECHNOLOGY. DURABLE BUILD QUALITY.



- ▶ **A speed for every task.** Fully synchronised gears and a shuttle lever makes for predictable and safe manoeuvring within the 12 forward and 12 reverse gears. In addition you can specify an additional 8 creep gears to be sure of a speed for every task.
- ▶ **Efficient and versatile rear PTO.** Efficient driveline design ensures that JX tractors transmit maximum power to your PTO driven machinery. For greater versatility and reduced fuel consumption there is the option to add a 540 Economy, 1000rpm or ground speed option.
- ▶ **Effective hydraulic performance.** With up to 61l/min oil flow available, there is always sufficient for controlled and effective operation. Whether using the rear linkage, materials handling with a front loader or tipping a trailer, each task is handled efficiently.
- ▶ **Case IH attributes.** JX tractors are part of the Case IH family of solutions for farmers, growers and business users. As such, JX benefits from the same key attributes of robust, solid build quality, technical support and ready parts availability as other Case IH products.

CASE IH JX RANGE – THE EFFECTIVE SOLUTION

THE CASE IH JX IS DESIGNED AS A NO-FRILLS UTILITY WORKHORSE, DELIVERING UNRIVALLED VALUE FOR MONEY. AIMED AT PART-TIME TO MEDIUM SIZED GROWERS AND FARMING ENTERPRISES AS WELL AS NON-FARMING BUSINESSES, THESE TRACTORS WILL FIND THEIR NICHE IN A WIDE RANGE OF OPERATING ENVIRONMENTS. JX IS SO VERSATILE AND EASY TO USE THAT OPERATORS QUICKLY BECOME PROFICIENT.

A perfect fit within your business. The specification of JX is such that new or novice operators can quickly become familiar, enabling a JX to perform the supporting role within a large enterprise that may have many drivers. In smaller operations, the economical purchase price and low running costs makes JX a wise investment that is easy to justify.

Frugal on specification - easy to operate. Whilst JX may not boast the technological sophistication of higher powered Case IH tractors, it delivers all the essential specification in a user-friendly manner. Instead of electronic switches, low effort mechanical levers provide positive, direct control over every function for simple yet practical operation.

Proven safety and design. JX tractors comply with all the latest safety standards for operator protection and the engines meet the Tier 3 requirement for emissions to ensure a clean, safe work environment. Proven transmission design, quality components and durability of construction are combined to ensure reliability. Whatever specification you choose, you can be confident that JX will perform.



▼ The new JX Range. The versatile workhorse you can rely on.



Model	Rated engine power (Tier 3) kW/hp(CV) @ 2,500rpm
Case IH JX 60	44/60
Case IH JX 70	53/72
Case IH JX 80	60/82
Case IH JX 90	65/88
Case IH JX 95	70/95

► **Easy Access.**

Solid Steps and wide opening doors give easy access to the comfort of a JX cab.

► **Always in control.**

Logically positioned controls and clear, concise instrumentation displays all relevant operating information.

► **An organised workspace.**

A cup holder and document storage pouch keeps the cab free from clutter.

► **Implements always in view.**

With slim cab pillars and large rear view mirrors the vision to working implements or following trailers is never at issue.



CAB AND CONTROLS

JX IS GENEROUS ON COMFORT AND SAFETY.

WHETHER YOU DRIVE THE TRACTORS IN YOUR OWN BUSINESS OR THEY ARE OPERATED BY YOUR EMPLOYEES, COMFORT AND SAFETY ARE IMPORTANT FACTORS. JX WILL NOT DISAPPOINT, AS THE SPIRIT OF PRACTICAL TECHNOLOGY CONTINUES INTO THE OPERATOR AREA.

Safe for everyone to use. Operator safety is integrated into every aspect of the JX design. Wide self cleaning steps and big grab rails help prevent the minor slips, whilst the rollover protection system (ROPS) or cab will protect the driver in case of an overturn. All JX operator stations are isolated from the transmission and engine to limit heat transfer and harmful vibration in order to provide a work environment which surpasses all current European health and safety legislation.

Cleared for access. As you rarely get to spend a full day in the seat, the flat floor of JX, will makes it easy to get on and off, even with muddy boots.

Sitting in comfort. Drivers of JX quickly become comfortable, and remain at their best right through the day. Seat armrests are standard equipment, the seat is readily adjusted to their needs and the suspension smooths out the shocks from rough field conditions or road transport. For additional comfort an air suspension seat can now be specified.

Work in all weather conditions. Rain, wind, snow or full sunshine, the JX cab will protect you, with heating for the cold winter months and ventilation for summer. Side and rear windows open for fresh air and air conditioning is available as an option.

Stay until the job is finished. When you have to meet a deadline and must work late, you can have confidence in JX. With up to six roof mounted worklights available to light the way and a rotary beacon for transport work, you can safely stay until the job is finished.



▲ Optional rotary beacon and worklights, help you stay safe on the road and in the field.

► **Powerful 4 cylinder diesel engines.** With 3.2 litre or 4.5 litre displacement, the engines of JX are in a class of their own when it comes to available torque, speed of response and fuel efficiency.

► **Turbocharged and intercooled.** JX engines are equipped with turbocharger and an air to air intercooler to boost thermal efficiency and extract maximum power from every drop of fuel.

► **Awesome torque reserves.** With up to 50% torque reserve JX engines are always ready to deliver a bit extra when you need it most.

► **Low effort.** A steady progression between ranges and synchronised gear changes ensure easy, efficient and low effort operation.



► **Define your needs.** Choose between an economical 12x4 or a 12x12 mechanical shuttle which transmission best fits your application.

► **Creep speed option.** With up to 8 additional low speed creep gears, JX is ideally suited to specialist vegetable farming usage.

► **Efficient PTO.** 540rpm is standard equipment and there is a choice of either 540 Economy for low power applications or 1000rpm for high power implements.

► **Proportional Ground speed.** For specialist machinery, this option enables the shaft output speed to be synchronised with tractor travel speed.

ENGINE, TRANSMISSION AND PTO

JX DRIVING YOUR OPERATION.

WITH FIVE MODELS BETWEEN 60 AND 95HP, WHATEVER THE POWER REQUIREMENTS OF YOUR BUSINESS, THERE WILL BE A JX TO FIT YOUR NEEDS. ECONOMICAL WITHOUT COMPROMISING ON POWER AND DURABILITY, JX DELIVERS UNBEATABLE VALUE FOR MONEY.

Greater staying power. With up to 50% of torque in reserve, JX engines have the ability to power through the peak loads or haul heavy trailers at speed on the road without the need for repeated gear changing. In addition, low fuel consumption and a big 118 litre fuel tank ensures you stay productive so the working day is not interrupted by the need to re-fuel.

Practical technology. The transmission utilises helical cut gear teeth, pressure lubricated bearings and synchronisers to provide a simple, efficient yet robust driveline. Gear speeds are spaced to have a steady progression between ranges and be fully compatible with operation around the yard, in the field or on road transport.

More working choice. For specialist applications, creep speed provides an additional 8 forward speeds from 250 metres per hour at rated engine speed. During operation, these ratios are engaged and dis-engaged by a separate lever transforming JX into the ideal vegetable transplanting or harvesting machine.

Manoeuvre with confidence. Around the yard or in confined spaces, the low effort hydrostatic steering and optional shuttle enables safe, efficient manoeuvring. With identical forward and reverse speeds, the driver need simply dip the clutch pedal to move the shuttle lever and reverse the direction of travel.

Excel at handling. The shuttle is particularly useful for the repetitive forward and back driving of loader applications. When equipped with a front end loader from the Case IH LRZ loader range, your JX will excel at lifting and handling big bales or other bulk materials to make light work of the biggest task.

▼ Controls are ideally positioned for ease of operation.



◀ **Biodiesel approved.** JX engines can run on up to 100% (B100) biodiesel.

▲ The rear PTO is effective in delivering full power.

► **Big capacity.** With a rear linkage capacity of up to 3565kg and a separate pump serving the external hydraulic circuit, JX is never short on ability.

► **Easy hitch control.** Rear hitch setting levers and remote valve controls are intuitive to operate.

► **Multiple operation.** With up to 4 double acting remote valves it is possible to control complex machines with ease.

▼ **Loader.** Loaders are easy to attach or remove and in cab controls are ideally positioned for ease of use.



► **Manoevrability in the field and around the yard.** An impressive steering angle, axle oscillation and short wheelbase ensure maximum agility.

► **A clear view.** Front fenders are available as an option for both. 2WD and 4WD tractors to keep window glass clear whatever the weather conditions.

► **Agricultural tyre options,** JX is available with many tyre options including narrow tyres for inter row cultivation tasks or wide tyres for reduced ground pressure.

► **Equipped for haulage.** Powerful brakes with auto 4WD engagement on 40kph models and optional hydraulic trailer brakes ensure safe high speed transport.

HYDRAULICS AND DRIVELINE

JX IS EQUIPPED TO POWER YOUR BUSINESS.

WHATEVER THE OPERATION, FROM LIFTING AND HANDLING TASKS WITH REAR LINKAGE OR CASE IH LRZ FRONT LOADER TO POWERING PTO DRIVEN IMPLEMENTS, JX TRACTORS HAVE THE VERSATILITY TO POWER YOUR BUSINESS.

Powerful hydraulics. A dedicated hydraulic pump supplies the rear hitch and external hydraulic functions giving fast, responsive operation during linkage, loader and trailer tipping work. For high demand applications, operating hydraulic motors or multiple hydraulic functions, a higher output 61l/min pump can be specified.

Easy hitch control. The robust rear 3 point hitch is capable of lifting and handling implements of up to 3565kg with ease. Depending on the nature of your work, separate levers allow the setting of hitch position and draft control for soil engaging implements, or any mix of the two. Once set, the raise and lowering can be triggered from the conveniently positioned fender top switch.

Efficient field performance. For improved in-field traction and better safety when operating on steep slopes, the four wheel drive front axle will be the natural choice. In tricky and slippery conditions, the limited slip differential will keep you going. For less demanding work a two wheel drive axle is available.

Safe, rapid road transport. JX tractors can be specified with a top speed of 40kph for rapid road transport. These four wheel drive tractors have an enhanced braking system to improve stopping performance and contribute to safer road transport.



▼ The conveniently positioned raise / lower switch simplifies linkage operation at the headland.



◀ In light duty applications, 2 wheel drive is often sufficient.

▶ In challenging situations, 4 wheel drive gives maximum traction and safety.



PARTS & SERVICE



Maintain the productivity of your investment. Case IH and its dedicated dealer network provide excellent support when you take delivery of your new machine and whilst it remains in your ownership. On the farm, you can rely on trained service professionals to maintain the productivity of your investment.

Protect the value of your investment. Behind every Case IH product stands an extensive European parts logistics organisation, stocking more than 700,000 part numbers for products old and new. Choosing to fit genuine Case IH parts will maintain the safety, value and performance of your original investment.



MAX – the new premium service from Case IH. We are always ready for you, around the clock, the whole year. Express delivery: when and where you need it. You get top priority during the season because your harvest cannot wait. The call is free. However some European Operators may apply a charge, if the call is made from a mobile phone. For any information about charge rate, please enquire in advance from your provider.

Extended protection programme. Case IH is at your side giving you the best professional solution: Safeguard from Covéa Fleet. This is the personalised insurance coverage for your Case IH machinery. Please contact your dealer for more details. Subject to status and availability. Terms and conditions apply.

DEALERS



Demand more from your Case IH dealership.

Purchasing a stand-alone piece of new equipment? Keeping a whole fleet up-to-date? Whatever your size of operation, contact your local Case IH dealership for professional advice on finance and future-safe business investment. Case IH knows your farming needs best.

FINANCE



Your local Case IH dealer can work with CNH Capital to offer solutions that best fit your budget and business goals. At CNH Capital, we understand that no two farms or agricultural businesses are the same. That's why we work so hard to understand your needs first. We make it our job to know your business inside and out – your goals, your ideas, and your unique outlook on the future. Then we can put together financial solutions and services that are right for you.



SPECIFICATIONS

	JX 60	JX 70	JX 80	JX 90	JX 95
ENGINE					
No. of cylinders / capacity (cm ³) / type	4 / 3200 / Turbocharged and Intercooled			4 / 4500 / Turbocharged and Intercooled	
Rated engine power ECE R120 ¹⁾ @ 2,500rpm (kW/hp[CV])	44 / 60	53 / 72	60 / 82	65 / 88	70 / 95
Max torque ECE R120 ¹⁾ @ engine rpm (kW/hp[CV])	217 @ 1250	280 @ 1250	328 @ 1250	375 @ 1300	390 @ 1300
Torque rise acc. OECD (%)	29	37	41	50	44
Fuel tank capacity - standard / optional (litres)	90	90	90 / 118	90 / 118	90 / 118
TRANSMISSION*					
Standard	12 Fwd / 4 Rev		12 Fwd / 12 Rev with mechanical shuttle		
Optional	12 Fwd / 12 Rev with mechanical shuttle		-	-	-
Optional with creeper	20 Fwd / 12 Rev with mechanical shuttle				
DRIVE and STEERING					
front axle standard / optional	2WD / 4WD with limited slip differential				
4WD front axle system standard / optional	electro-hydraulic engagement / -		electro-hydraulic engagement / mechanical engagement		
Rear differential lock system 2WD	electro-hydraulic engagement				
Rear differential lock system 4WD	(mechanical engagement optional)				
4WD optional feature	-	-	brake discs integrated into front axle		
Turning radius 2WD / 4WD	3800 / 4900	3800 / 4900	3900 / 5100	3900 / 5100	3900 / 5100
POWER TAKE OFF					
Type	mechanical engagement				
Rear pto speeds standard	540 / 540E / proportional ground speed				
Rear pto speeds optional	540 / proportional ground speed or 540 / 1000 / proportional ground speed				
HYDRAULIC SYSTEM					
Max pump flow - steering / hitch and external services	26.5l/min / 45l/min (optional 61l/min)				
Remote valves	max 4 rear mounted Open Centre type				
Rear linkage control type	MHC (Mechanical Hitch Control)				
Rear lift capacity (kg)	3000	3000	3565	3565	3565
WEIGHTS* and DIMENSIONS ²⁾					
Minimum weight ³⁾ / Permissible total weight ³⁾ (kg)	3440 / 5400	3440 / 5400	3620 / 5800	3730 / 5900	3780 / 6000
A - Max length ³⁾ (mm)	4157	4157	4157	4244	4264
B - Min - Max track width ³⁾ (mm)	1425 - 1925	1425 - 1925	1400 - 2000	1400 - 2000	1400 - 2000
C - Max height ³⁾ over cab (mm)	2577	2577	2627	2627	2652
Max height over ROPS (mm)	2710	2710	2760	2760	2785
D - Wheelbase - 2WD / 4WD (mm)	2265 / 2225	2265 / 2225	2281 / 2225	2368 / 2312	2388 / 2332
STANDARD TYRES*					
Front 2WD / 4WD	7.50-16 / 11.2 R24	7.50-16 / 11.2 R24	9.00-16 / 13.6 R24	9.00-16 / 13.6 R24	9.00-16 / 13.6 R24
Rear	16.9 R30	16.9 R30	16.9 R34	16.9 R34	18.4 R34

* to comply with legislation and specification in your country

1) ECE R120 correspond to ISO TR14396 2) with standard tyres 3) 4WD cab tractor

LRZ LOADERS	LRZ 95
Max. lift capacity (kg)	2060
Max. height (mm)	3740
Power range (hp)	70-100

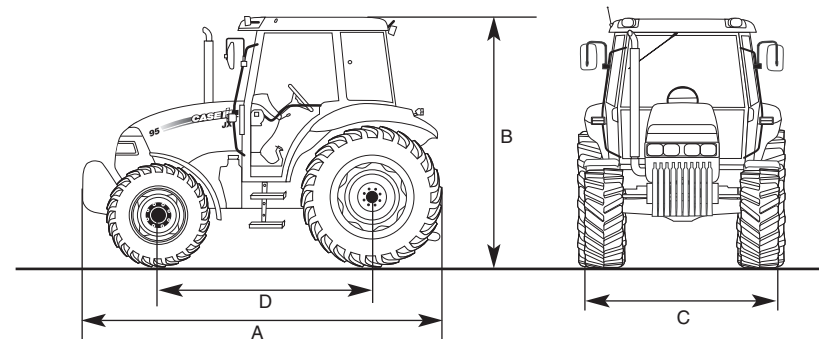

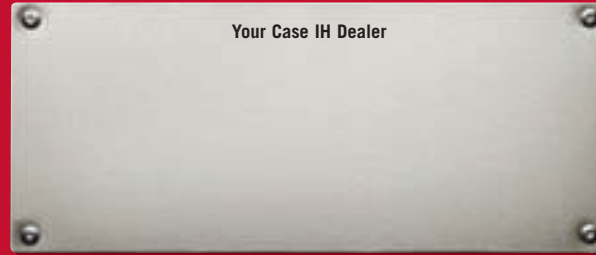

WWW.CASEIH.COM



Safety never hurts! Always read the Operator's Manual before working with any equipment. Inspect equipment before using it, and be sure it is operating properly. Follow the product safety signs, and use any safety features provided.

This literature has been published for worldwide circulation. The standard and optional equipment and the availability of individual models may vary from one country to the next. Case IH reserves the right to undertake modifications without prior notice to the design and technical equipment at all times without this resulting in any obligation whatsoever to make such modifications to units already sold. Whilst every effort is made to ensure that the specifications, descriptions and illustrations in this brochure are correct at the time of going to press, these are also subject to change without prior notice. Illustrations may show optional equipment or may not show all standard equipment.

Case IH recommends **AKCELA**™ lubricants

CNH UK Ltd., Cranes Farm Road, Basildon, Essex SS14 3AD - © 2011 CASE IH - www.caseih.com - JX Series-UK-BR - Free phone 00800 22 73 44 00 - Printed in Italy - 06/11 - TP01 - Cod. 9C0003/INB