

# MODEL RANGE

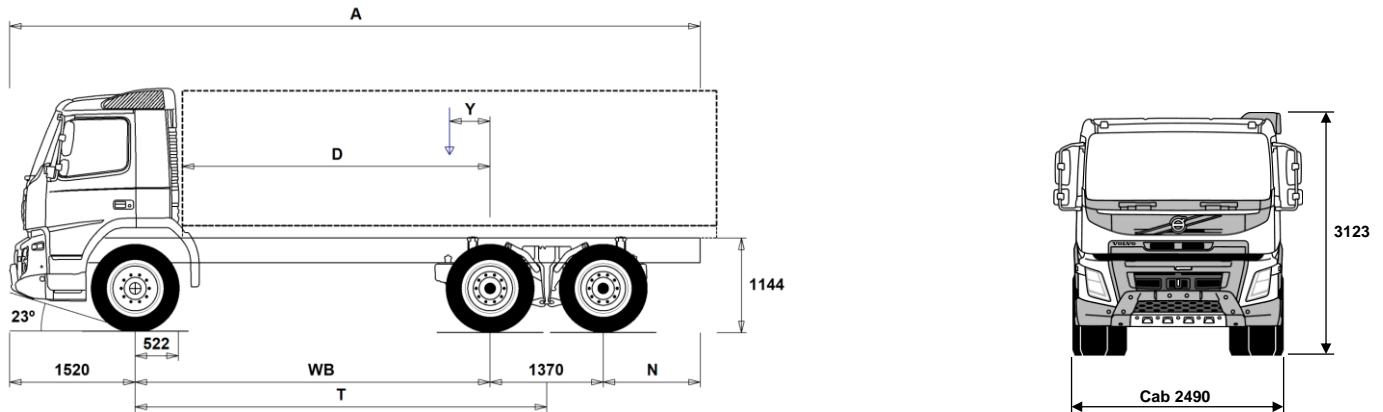

Volvo Trucks. Driving Progress

FMX13 6x4 Rigid - X-High Rear Air Suspension - N3G Straight front axle FM 64 R3CAX



## Chassis Dimensions [mm]

| WB Wheelbase                           | 3400 | 3700 | 3900 | 4300 | 4600 |
|--|------|------|------|------|------|
| A Overall Chassis Length               | 7465 | 7765 | 7665 | 8065 | 8665 |
| D Center of rear axle to front of body | 2828 | 3128 | 3328 | 3728 | 4028 |
| N Rear Overhang (Min.)                 | 825  | 825  | 825  | 825  | 825  |
| N Rear Overhang (Max.)                 | 1175 | 1175 | 875  | 875  | 1175 |
| T Theoretical Wheelbase                | 4085 | 4385 | 4585 | 4985 | 5285 |
| Y Center of Gravity for Payload (Min.) | -159 | -125 | -106 | -63  | -27  |
| Y Center of Gravity for Payload (Max.) | 73   | 124  | 154  | 221  | 275  |

## Chassis Weights [kg]

|  |       |       |       |       |       |
|--|-------|-------|-------|-------|-------|
| Front Axle                                   | 4725  | 4745  | 4775  | 4805  | 4820  |
| Rear Bogie                                   | 3620  | 3630  | 3605  | 3630  | 3675  |
| Kerb Weight                                  | 8345  | 8375  | 8380  | 8435  | 8495  |
| Payload (including body, driver, fuel, etc.) | 17655 | 17625 | 17620 | 17565 | 17505 |

## Turning Diameter [mm]

|                                      |       |       |       |       |       |
|--------------------------------------|-------|-------|-------|-------|-------|
| Turning Circle Diameter Kerb to Kerb | 14500 | 15500 | 16100 | 17300 | 18200 |
| Turning Circle Diameter Wall to Wall | 16000 | 16900 | 17500 | 18800 | 19700 |

## Plated Weights [kg]

|                          | Plated | Design |
|--------------------------|--------|--------|
| Gross Vehicle Weight     | 26000  | 29000  |
| Gross Combination Weight | 44000  | 44000  |
| Front Axle               | 8000   | 8000   |
| Rear Bogie               | 19000  | 21000  |

## Important Notes

### Chassis Dimensions

Cab Height: +416 mm for CAB-HSLP.  
 Front Axle to Back of Cab: +424 mm for CAB-HSLP and CAB-SLP.  
 D-measure includes a front clearance of 50 mm and for rigid trucks also a subframe of 100 mm.  
 Height can vary  $\pm 20$  mm for leaf and  $\pm 10$  mm for air suspension.  
 All dimensions are for unladen chassis and any tag axles down.  
 Rear overhang used for vehicle weight calculation is the maximum rear overhang (N Max.) for selected wheelbase.

Weight and dimensions are based upon the following tyres:

|                   |             |
|-------------------|-------------|
| Front Axle Tyres: | 315/80R22.5 |
| Drive Axle Tyres: | 315/80R22.5 |

**Chassis weight includes oil, water, AdBlue, 0 litres fuel and without driver. Kerb weight can vary  $\pm 3\%$ .**

Turning diameters are theoretically calculated.

Legal weights can differ from country to country.

For more detailed weight information, including optional equipment weights, ask your Volvo sales contact to enter your specification into the Volvo Weight Information system (WIS).

Do NOT use this drawing for bodybuilding. Refer to Volvo Bodybuilder Instructions and chassis assembly drawing FM64R3CAX.

# MODEL RANGE

FMX13 6x4 Rigid - X-High Rear Air Suspension - N3G Straight front axle FM 64 R3CAX

## TRUCK USE

- **RC-ROUGH** Operating class on/off road
- **GARB-PRE** Garbage preparation
- **TIPP-PRE** Tipper vehicle preparation

## CORE COMPONENTS

- **CHH-XHIG** Chassis height Extra High - For a specific loading height always check the unique BEP chassis drawing
- **RADD-G2** Rear air suspension, 2 axles - 2 driven, high ground clearance
- **FMX-DAY** Day cab - with steel safety cage design  
Designed and built to Swedish impact and ECE R29 regulations
- **FMX-HSLP** Globetrotter cab - with steel safety cage design  
Designed and built to Swedish impact and ECE R29 regulations
- **FMX-SLP** Sleeper cab - with steel safety cage design  
Designed and built to Swedish impact and ECE R29 regulations
- **EU6SCR** Emission level - Euro 6
- **D13K420** D13K420 12.8l engine developing 420hp at 14-1800rpm.  
Peak torque 2100Nm at 860 -1400rpm.
- **D13K460** D13K460 12.8l engine developing 460hp at 14-1800rpm.  
Peak torque 2300Nm at 900-1400rpm.
- **D13K500** D13K500 12.8l engine developing 500hp at 14-1800rpm.  
Peak torque 2500Nm at 1000-1400rpm.
- **D13K540** D13K540 12.8l engine developing 540hp at 14-1800rpm.  
Peak torque 2600Nm at 1000-1450rpm.
- **EBR-EPG** Exhaust brake controlled by steering column switch
- **EBR-EPGC** Exhaust pressure governor for I shift gearbox
- **EBR-VEB+** Volvo engine brake + and exhaust pressure governor, enhanced performance from additional exhaust rocker control.  
Retardation 375kW
- **AT2612F** AT2612F 12-speed "I-shift" automated mechanical gearbox suitable for gross train weights up to 60tonne only refer to sales engineering when used in conjunction with a PTO
- **ATO2612F** ATO2612F 12-speed "I-shift" overdrive automated mechanical gearbox suitable for gross train weights up to 60tonne refer to sales engineering when used in conjunction with a PTO
- **PT2606** Powertronic automatic 6-speed gearbox, max. engine torque 2600 Nm, max. permitted GCW 130000 kg
- **SPO2812** SPO2812 - 12 speed I-shift Dual Clutch automated mechanical gearbox GCW 60tonne
- **TAAXLIFT** Rear axle lift for double drive bogie  
CONTACT YOUR SALES ENGINEER to check lift capability
- **RTH2610F** RTH2610F hub reduction tandem 26tonne drive axles, GCW 100 tonnes with differential and cross locks\*  
\* Cross locks replaced by a dog clutch if tandem axle lift is specified
- **RTS2370A** RTS2370A single reduction tandem 23tonne drive axles with differential and cross locks\* - design GCW 70tonnes.  
\* Cross locks replaced by a dog clutch if tandem axle lift is specified

## PACKAGES

- **DRIVEFM** Driving package
- **DRIVEFM+** Driving plus package
- **BEDFM** One bed resting package
- **AUDHIG** High Power Audio system: RDS radio with CD player - also playing MP3/WMA files from CD -, with integrated bluetooth phone and USB/Line inputs. FM/AM antenna, speakers in dashboard, doors, and sleeping compartment.
- **MEDIA** AM/FM Bluetooth radio without CD player.  
USB and Aux line inputs.  
Speakers in dashboard, doors, and sleeping compartment.  
7" touch screen with personal apps.
- **MEDIADF** AM/FM Bluetooth radio without CD player.

- Standard Equipment
- Optional Equipment

For more detailed information about cab and powertrain equipment, please refer to separate specification sheets.

For all possible options and combinations of options please consult your Volvo sales contact who can create a specification to match your requirements using the Volvo Sales Support system (VSS).

The factory reserves the right to modify design and change equipment without previous notification.  
The specification can vary from country to country.

- **MEDIANAV** AM/FM Bluetooth radio without CD player.  
USB and Aux line inputs.  
Speakers in dashboard, doors, and sleeping compartment.  
7" touch screen with personal and professional apps.  
Dynafleet vehicle on-board data display with office internet support.
- **MEDIANDF** AM/FM Bluetooth radio without CD player.  
USB and Aux line inputs.  
Speakers in dashboard, doors, and sleeping compartment.  
7" touch screen with personal and professional apps.  
Truck based satellite navigation (live updates not included)  
Dynafleet vehicle on-board data display with office internet support.
- **VISIX15** Visibility package
- **CHASSIS**
  - **FST-PAR3** Front suspension type - 3 leaf parabolic springs
  - **FAL10.0** Front axle design capacity 10 tonnes - Ensure that you have checked the tyre load index
  - **FAL8.0** Front axle design capacity 8.0 tonnes - Ensure that you have checked the tyre load index
  - **FAL9.0** Front axle design capacity 9.0 tonnes - Ensure that you have checked the tyre load index
  - **FSM-LUB** Lubricated rear shackles on front suspension pins and bushings
  - **FSTAB** Front anti-roll bar
  - **FSTAB2** Front anti-roll bar medium stiffness
  - **FSTAB3** Front stiff anti-roll bar
  - **RAL21** Rear bogie design capacity 21 tonnes
  - **RAL23** Rear bogie design capacity 23 tonnes
  - **RAL26** Rear bogie design capacity 26 tonnes
  - **RSTAB3** Rear stiff anti-roll bar
  - **RALIM105** Rear axle load limiter, 10.5 tonnes
  - **RALIM115** Rear axle load limiter, 11.5 tonnes
  - **RALIM13** Rear axle load limiter, 13 tonnes
  - **RALIM95** Rear axle load limiter, 9.5 tonnes
  - **ASF-DL3** Air suspension with 3 driving levels
  - **ACTST-TO** Volvo Dynamic Steering (VDS) with with extra electronic pump and torque overlay
  - **ASFE-BAS** Active steering feature - Basic - Volvo Dynamic Steering only
  - **ASFE-PS** Active steering feature - Volvo Dynamic Steering with personal settings
  - **PSS-SING** Single power steering system
  - **PSP-FIX** Power steering pump with fixed displacement
  - **PSP-VAR** Power steering pump with variable displacement
  - **EBS-MED** EBS medium package including "hill" hold function
  - **AUXPARK** Additional spring parking brakes
  - **ABS** Anti lock brakes
  - **FBREG-E** Front regulating brake valve, EBS
  - **SUSPL-EC** Remote electronic control on wander-lead for air suspension levelling
  - **FRAME266** Frame rail section external height 266 mm
  - **FRAME300** Frame rail section external height 300 mm
  - **FST7070** Frame thickness - web and flange 7.0mm
  - **FST8080** Frame thickness - web and flange 8.0mm
  - **FIL-EEEB** Inner liner from end of engine to end of bogie
  - **FIL-EEEE** Inner liner from end of engine to end of frame
  - **FIL-FBEB** Inner liner over rear bogie
  - **FIL-FBEF** Inner liner from front of bogie to end of frame
  - **FIL-TXEB** Inner liner from gearbox member to end of bogie

# MODEL RANGE

## FMX13 6x4 Rigid - X-High Rear Air Suspension - N3G Straight front axle FM 64 R3CAX

- FIL-TXEF** Inner liner from gearbox member to end of frame
- BBOX-L** Battery box located on left hand side
- 2BAT210B** 2 x 210 Ah capacity Gel batteries
- 2BATT170** 2 x 170 Ah capacity batteries
- 2BATT225** 2 x 225 Ah capacity batteries
- BATTAMP** Battery voltage and ampere gauge
- BATTIND** Battery charge indication
- ADR2** ADR package for transportation of dangerous goods on road (Note does NOT include safe loading pass package if required this is quoted separately)
- MSWI-A** Main switch - ADR switch circuit shut down
- MSWI-C** Main switch - Chassis mounted toggle switch by battery box
- MSWI-R** Main switch - Key fob operated remote controlled
- R315A56** Right aluminium 560 mm D-shaped fuel tank, 315 litres volume  
Min volume 255l  
Max volume 885l
- UL-FUEL** Without left fuel tank  
Min volume 160l  
Max volume 730l
- ADTP-L** AdBlue tank on left hand side
- ADTP-R** AdBlue tank on right hand side
- ADB048** AdBlue tank usable volume 48 litres
- ADB064** AdBlue tank usable volume 64 litres
- ADB068** AdBlue tank usable volume 68 litres
- ADB090** AdBlue tank usable volume 90 litres
- ADB100** AdBlue tank usable volume 100 litres
- FCAP-L** Locking fuel filler cap
- FUFF-AS** Fuel filling anti-spillage device
- FUFF-ATS** Fuel filling anti-theft and anti-spillage devices
- ESH-LEFT** Horizontal silencer, left exhaust outlet
- ESH-REAR** Horizontal silencer, rear exhaust outlet
- ESH-RIGH** Horizontal silencer, right exhaust outlet
- ESH-VERT** Horizontal silencer, vertical exhaust outlet
- EXST-SSP** Stainless steel exhaust stack - NOT polished
- EXST-ST** Steel exhaust stack
- HS-NAR** Narrow heat shield
- WHC-FIX2** Two fixed wheel chocks
- WHC-FOL2** Two foldable wheel chocks
- WHCP-F** Wheel chock(s) stored in the front part of the vehicle
- WHCP-M** Wheel chock(s) stored in the middle part of the vehicle
- WHCP-R** Wheel chock(s) stored in the rear part of the vehicle
- WHCP-T** Transport mounted wheel chock(s) stored in cab outer luggage locker
- TB-L80** Toolbox 800 mm, left side
- TB-R80** Toolbox 800 mm, right side
- CHAIN-S** Snow chains
- HOOK-SC** Snow chain hooks
- TOWF-HD1** One heavy duty front towing device
- TOWMBR1** Towing member, high mounted in centre of frame, D = 190
- TOWMBRL1** Towing member, low mounted under the frame
- TOWMBRM** Towing member, medium mounted in line with frame lower flange
- RFEC-L** Rear frame end, lower flange cut for centre axle drawbar.
- RFEC-S** Rear frame end, straight cut for regular platform applications
- RFEC-U** Rear frame end, upper cut for tipper applications.
- C-RI4040** Towing coupling, Ringfeder 4040 G-150
- C-RI5055** Towing coupling, Ringfeder 5055 G-150
- C-RO400G** Towing coupling, Rockinger 400 G-150 for 40mm eyes
- C-RO50** Rockinger RO 50 50mm for centre axle trailer
- TOWR-ONE** Towing hitch attached to rear crossmember
- TREL-PK** Trailer electrical preparation kit - chassis/cab wiring
- TREL14** Single 14 pole electrical trailer connector
- TREL15** Single 15 pole electrical trailer connector - ADR certified
- TREL7** 7 pole - 24N trailer electrical suzie
- TREL7-7** 24N and 24S trailer electrical suzies
- TBC-DUO** Duomatic type air line connectors
- TBC-EC** Palm coupling type air line connectors
- TRBR-HCF** Full pressure hand controlled trailer brake
- TRBR-STA** Stationary trailer brake control
- TRB-STRE** Stretch Brake - Automatic low speed trailer brake activation to avoid jack-knifing and improve steerability
- RUP-FOSL** Folding & sliding EC approved aluminium rear underrun
- RFEND-B** Three piece EC approved rear mud wings and spray flaps
- RFEND-T** Rear mud wings, transport mounted
- RFH-BAS** Basic rear wing height
- RFH-HIG** High rear wing height - higher wing tops
- RFH-LOW** Lower rear wing height - shallower wing tops
- AUXATNK** Auxiliary airtank
- ATANK-AL** Aluminium air tanks
- ATANK-ST** Steel air tanks
- RESTS-W** White conspicuity markings on chassis - sideguards, toolbox and rear overhang
- REST-RUP**
- TL-LED** LED Tail lights
- BLIGHT-E** Emergency brake light
- WHEELS & TYRES**
- RT-AL** Alcoa brushed aluminium rims with standard holes for long stud fixing on all axles
- RT-ALDP** Alcoa Dura-Bright EVO aluminium rims with standard holes long stud fixing on all axles, requires cleaning with a ph neutral solution - washing up liquid.
- RT-ALDPD** Alcoa Dura-Bright EVO aluminium rims with countersunk holes for short stud fixing on all axles, requires cleaning with a ph neutral solution - washing up liquid.
- RT-ALDU** Alcoa brushed aluminium rims with countersunk holes for short stud fixing on all axles
- RT-SPOKE** Spoke rims on all axles
- RT-STEEL** Steel rims on all axles
- WCAP** Aerodynamic hub caps
- BRREC001** Bridgestone ECOPIA H - Energy rating C
- COREC002** Continental ECOPLUS HS3/HD3 - Energy rating B or C depending on size
- GYREC001** Good Year FUELMAX S/HL/D - Energy rating B or C depending on size
- GYREC002** Good Year FUELMAX S/D - Energy rating B or C depending on size
- GYREC003** Good Year FUELMAX S/(O)/D - Fuel tyre Recommendation 3
- MIREC002** Michelin XZA2/X-LINE Energy - Fuel tyre Recommendation 2
- MIREC003** Michelin X-LINE Energy - Fuel tyre Recommendation 3
- MIREC004** Michelin X Line Energy F/D2 - Energy rating A
- SPWT-D** Spare wheel & tyre with rear tyre pattern
- SPWT-F** Spare wheel & tyre with front tyre pattern
- SWCP-LF** Spare wheel carrier on left side of chassis ahead of rear axle
- SWCP-R** Rear mounted spare wheel carrier
- SWCP-T** Spare wheel supplied temporarily strapped to chassis
- SWCP-TP** Temporary spare wheel carrier on top of chassis frame
- JACK-12T** 12 tonne bottle jack
- JACK-15T** 15 tonne bottle jack
- JACK-20T** 20 tonne bottle jack
- TOOL-BAS** Basic Toolkit
- TOOLKIT** Complete tool kit
- INFLAHOS** Tyre inflation hose
- GAUGE-TP** Tyre pressure gauge

Standard Equipment

Optional Equipment

For more detailed information about cab and powertrain equipment, please refer to separate specification sheets.

For all possible options and combinations of options please consult your Volvo sales contact who can create a specification to match your requirements using the Volvo Sales Support system (VSS).

The factory reserves the right to modify design and change equipment without previous notification. The specification can vary from country to country.

# MODEL RANGE

## FMX13 6x4 Rigid - X-High Rear Air Suspension - N3G Straight front axle FM 64 R3CAX

- OBDEP-C** Euro 6 Step C emission level
- OBDEP-D** Euro 6 Step D emission level
- DRIVELINE EQUIPMENT**
- ASO-C** Crawler gear -  
Ratio direct top gearbox 19:1  
Ratio Overdrive gearbox 17:1
- ASO-ULC** Ultra low crawler and crawler gear -  
Ratios direct top gearbox 32:1 and 19:1  
Ratios Overdrive box 32:1 and 17:1
- TRAP-HD** Reinforced gearbox application
- TP-CON** Construction Package
- TP-DIST** Distribution Package
- TP-HD** I-shift software - Heavy duty for high GCW  
Special conditions apply consult Sales Engineering
- TP-LONG** Long Haul Package
- AMSO-AUT** Enhanced I-shift software with manual shift available in auto mode and kickdown facility on accelerator pedal
- AVO-ENH** Enhanced software for off road driveability and starting
- APF-ENH** I-shift enhanced PTO functions
- CD43-O** Dual plate clutch, plate diameter 430 mm
- CS43B-O** Single plate 430mm (17") clutch
- RET-TH** Gearbox mounted retarder
- RET-TPT** Hydraulic Retarder for Powertronic gearbox
- TC-HWO** Automatic gearbox oil cooler - water to oil
- TC-MAOH2** Extra high performance transmission oil cooler - air to oil with front mounted radiator
- TC-MWO** Basic transmission oil cooler - water to oil
- TC-MWOH2** High performance transmission oil cooler - water to oil
- 2COM1100** Two cylinder, air compressor, 1100 litres per minute
- 2COMP900** Two cylinder, air compressor, 900 litres per minute
- CLU-AIRC** Clutchable air compressor
- AIRIN-HI** Roof mounted air intake behind cab on left hand side
- AIRIN-LO** Low level air intake behind cab on left hand side
- ACL1ST-S** Two stage air filter
- 24AL110B** 110 amp alternator
- 24AL120B** 120 amp alternator
- 24AL150B** 150 amp alternator
- CCV-C** Closed crankcase engine ventilation
- CCV-O** Open crankcase engine breather
- CCV-OX** Closed crankcase ventilation for cold markets
- PRIM-EL** Electrical priming pump
- PRIM-MAN** Manual priming pump
- FUEQ-EH** Fuel line electric heater
- AF-R** Hot fuel recirculation heated fuel filter
- FUEFE2LW** Large engine mounted dual fuel filter with water separator
- FUEFE2SW** Small engine mounted dual fuel filter with water separator
- EST-AID** Air inlet manifold starting heater element
- 220EBH15** 220V/1.5Kw electric engine block heater
- PTER-100** Rear engine mounted power-take-off with DIN 100 / ISO 7646 flange
- PTER-DIN** Rear engine mounted PTO with DIN5462 (female) splined shaft for a close coupled pump.  
Models with 3 steering axles will use this to drive the steering pump (AUXPSP)
- PTER1400** Rear engine mounted power-take-off with SAE 1410 flange
- HPE-F101** Parker F1-101, engine mounted, fixed displacement, single flow, engine mounted hydraulic pump
- HPE-F41** Parker F1-41, engine mounted, fixed displacement, single flow, engine mounted hydraulic pump
- HPE-F51** Parker F1-51, engine mounted, fixed displacement, single flow, engine mounted hydraulic pump
- HPE-F61** Parker F1-61, engine mounted, fixed displacement, single flow, engine mounted hydraulic pump
- HPE-F81** Parker F1-81, engine mounted, fixed displacement, single flow, engine mounted hydraulic pump
- HPE-T53** Parker F2-53/53, engine mounted, Fixed displacement, Twin flow engine mounted hydraulic pump
- HPE-T70** Parker F2-70/35, engine mounted, Fixed displacement, Twin flow engine mounted hydraulic pump
- HPE-V45** Parker VP1-45, variable displacement, single flow, engine mounted hydraulic pump
- HPE-V75** Parker VP1-75, variable displacement, single flow, engine mounted hydraulic pump
- PTPT-D** Powertronic PTO, 1 front/upper DIN connection for plug-in pump (max. 850 Nm)
- PTPT-F** Powertronic PTO, 1 front/upper rear facing SAE flange conn. for prop shaft (max.850 Nm)
- PTR-D** Gearbox PTO for plug-in pump, 0.71xeng speed
- PTR-DH** Gearbox driven high speed PTO for one plug-in hydraulic pump
- PTR-DM** Gearbox driven medium speed PTO for one plug-in hydraulic pump
- PTR-F** Gearbox driven PTO with rear flange connection
- PTR-FH** Gearbox driven high speed PTO with SAE drive flange
- PTR-FL** Gearbox driven low speed PTO with SAE drive flange
- PTRD-D** Gearbox driven HIGH SPEED PTO for two plug-in hydraulic pumps
- PTRD-D1** PTRD-D1 Gearbox driven HIGH SPEED PTO (1 SAE flange & 1 plug-in hydraulic pump)
- PTRD-D2** Gearbox driven HIGH SPEED PTO (2 SAE flanges & 1 plug-in hyd pump)
- PTRD-F** PTO with 1 DIN + 1 flange connection rear, manual gearbox
- HPG-F101** Parker F1-101 gearbox mounted, fixed displacement, single flow, hydraulic pump
- HPG-F41** Parker F1-41 gearbox mounted, fixed displacement, single flow, hydraulic pump
- HPG-F51** Parker F1-51 gearbox mounted, fixed displacement, single flow, hydraulic pump
- HPG-F61** Parker F1-61 gearbox mounted, fixed displacement, single flow, hydraulic pump
- HPG-F81** Parker F1-81 gearbox mounted, fixed displacement, single flow, hydraulic pump
- EIDLESD** Engine idle shut down
- STWPOS-L** LEFT HAND DRIVE
- STWPOS-R** RIGHT HAND DRIVE
- STWM-LE** Leather steering wheel
- STGW-AD2** Adjustable steering wheel with neck tilt
- STGW-ADJ** Adjustable steering wheel
- AIRBAG** SRS Driver's air bag
- DRC-AMII** DPF Regeneration control switch - for manual and switching off regeneration
- 1DAYDIG** Continental VDO DTCO 3.0 digital tachograph  
This tachograph can ONLY offer remote download if the option of Dynafleet or an FMS gateway has been specified with this order.
- 1DAYDIG2** Continental VDO DTCO 4.0 smart tachograph  
This tachograph can ONLY offer remote download if the option of Dynafleet or an FMS gateway has been specified with this order.
- 1DAYDIGP** Continental VDO DTCO 3.0 digital tachograph  
For vehicles with long lead time - this includes prep kit for the retrofit of DTCO 4.0 tachograph.  
For updating to new legal demand for trick registration from 15th June 2019.  
This tachograph can ONLY offer remote download if the option of Dynafleet or an FMS gateway has been specified with this order.
- ARSL** Additional road speed limit - switch in dashboard

■ Standard Equipment

□ Optional Equipment

For more detailed information about cab and powertrain equipment, please refer to separate specification sheets.

For all possible options and combinations of options please consult your Volvo sales contact who can create a specification to match your requirements using the Volvo Sales Support system (VSS).

The factory reserves the right to modify design and change equipment without previous notification. The specification can vary from country to country.

# MODEL RANGE

## FMX13 6x4 Rigid - X-High Rear Air Suspension - N3G Straight front axle FM 64 R3CAX

- |  |   |
|--|---|
| <ul style="list-style-type: none"> <li><input type="checkbox"/> <b>SPEED-DU</b> Dual speed limiter</li> <li><input type="checkbox"/> <b>CRUIS-E</b> Eco cruise control (with eco-roll and I-cruise, controls in steering wheel)</li> <li><input checked="" type="checkbox"/> <b>CRUISEC</b> Cruise control, standard</li> <li><input checked="" type="checkbox"/> <b>ESP-BAS1</b> Electronic Stability Control</li> <li><input type="checkbox"/> <b>ESPC-RO</b> ESP (Electronic Stability Program) functionality control - Reduced / Off</li> <li><input type="checkbox"/> <b>HWSS-ACB</b> Adaptive cruise control with forward collision warning and advanced emergency braking</li> <li><input type="checkbox"/> <b>HWSS-FCB</b> Forward collision warning with basic cruise control and advanced emergency brake</li> <li><input type="checkbox"/> <b>LSS-DW</b> Lane departure warning system</li> <li><input type="checkbox"/> <b>LCS</b> Lane change support</li> <li><input type="checkbox"/> <b>DAS-W</b> Driver Alert Support system</li> <li><input type="checkbox"/> <b>RSSENS-W</b> Rain sensing windscreen wipers</li> <li><input type="checkbox"/> <b>CU-ECC</b> Electrically controlled air conditioning with sun sensor</li> <li><input type="checkbox"/> <b>CU-ECC2</b> Electrically controlled air conditioning with sun sensor, mist sensor, air quality sensor and carbon filter</li> <li><input checked="" type="checkbox"/> <b>CU-MCC</b> Climate unit with manual controlled air conditioning</li> <li><input checked="" type="checkbox"/> <b>IMMOBIL</b> Thatcham H2 approved immobiliser</li> <li><input type="checkbox"/> <b>ALARM-B</b> Thatcham H1 approved vehicle alarm - Cab only</li> <li><input type="checkbox"/> <b>ALARM-E</b> Enhanced vehicle alarm - Thatcham H1 approved - Cab plus external sensor for body/trailer</li> <li><input type="checkbox"/> <b>ALCOLOCK</b> Alcolock</li> <li><input type="checkbox"/> <b>PHONE-PK</b> Telephone preparation kit (antenna, antenna attachm. cable incl.)</li> <li><input type="checkbox"/> <b>WLIFT-AD</b> Electrical window lift, automatic up/down driver side</li> <li><input checked="" type="checkbox"/> <b>WLIFT-EB</b> Electrical window lift</li> <li><input type="checkbox"/> <b>WLIFT-ME</b> Mechanical window lift</li> <li><input type="checkbox"/> <b>ISUNS-BS</b> Side interior sun visor on both sides</li> <li><input checked="" type="checkbox"/> <b>ISUNS-DS</b> Driver's side interior sun visor</li> <li><input checked="" type="checkbox"/> <b>ISUNF-B</b> Interior front sun visor without mirror</li> <li><input type="checkbox"/> <b>ISUNF-MD</b> Interior front sun visor with mirror on driver side</li> <li><input type="checkbox"/> <b>ISUNF-RE</b> Electrically operated textile interior sun blind</li> <li><input type="checkbox"/> <b>ISUNF-RM</b> Manually operated textile interior sun blind</li> <li><input type="checkbox"/> <b>ADFS</b> Two extra DIN slots in front shelf - can be fitted with card or drawer available as an accessory</li> <li><input checked="" type="checkbox"/> <b>BUPALARM</b> Reverse alarm</li> <li><input type="checkbox"/> <b>BUPMON</b> Back up monitor with built in 7" screen on dash and one colour camera supplied loose for fitment by bodybuilder.</li> <li><input type="checkbox"/> <b>RTOLL-PK</b> Road toll PREPARATION kit for trucks operating with "Toll Collect" in Germany</li> <li><input type="checkbox"/> <b>LOADIND</b> Load indicator with central dashboard display</li> <li><input type="checkbox"/> <b>REMC-MF</b> Multi-functio wireless remote control</li> <li><input type="checkbox"/> <b>FIREXT3S</b> 3kg fire extinguisher mounted on seat base</li> <li><input type="checkbox"/> <b>WARNVEST</b> High visibility warning vest - no sleeves</li> <li><input type="checkbox"/> <b>AIDKIT</b> First aid kit</li> <li><input type="checkbox"/> <b>AIDKIT1B</b> First aid kit</li> <li><input type="checkbox"/> <b>WARNLAMP</b> Portable warning lamp</li> <li><input type="checkbox"/> <b>LAMP-IN</b> Inspection lamp</li> <li><input type="checkbox"/> <b>BULBKIT</b> Bulb and fuse kit</li> <li><input type="checkbox"/> <b>WRITEPAD</b> Writing pad</li> <li><input type="checkbox"/> <b>UPHTRI10</b> Seats: Black embossed textile insert with light grey sides, black vinyl side bolster with blue vinyl side insert.<br/>Interior trim: Raven black bunk and curtains &amp; blue textile side walls</li> <li><input checked="" type="checkbox"/> <b>UPHTRI11</b> Seats: Light grey embossed textile insert, black raven metallic</li> </ul> | <ul style="list-style-type: none"> <li><input type="checkbox"/> <b>UPHTRI12</b> Seats: Blue soft textile insert, black vinyl bolster.<br/>Interior trim: Raven black bunk and curtains &amp; blue textile side walls</li> <li><input type="checkbox"/> <b>UPHTRI13</b> Seats: Dark grey leather insert and black leather bolster.<br/>Interior trim: Raven black bunk and curtains &amp; grey vinyl side walls</li> <li><input type="checkbox"/> <b>UPHTRI14</b> Seat: Dark grey leather insert and black leather bolster.<br/>Interior trim: Raven black bunk and curtains &amp; blue textile side walls</li> <li><input checked="" type="checkbox"/> <b>DST-CF4</b> Driver seat, comfort, suspended, belt in seat</li> <li><input type="checkbox"/> <b>DST-CF5</b> Driver seat, comfort, suspended, belt in seat, electrically heated</li> <li><input type="checkbox"/> <b>DST-CF6</b> Driver seat, comfort, suspended, belt in seat, electrically heated, ventilated</li> <li><input type="checkbox"/> <b>SBD-RED</b> Red seat belts</li> <li><input type="checkbox"/> <b>SBPRE-DS</b> Driver seat belt pretensioner</li> <li><input checked="" type="checkbox"/> <b>PST-BAS1</b> Passenger seat - Fixed non suspended fold up with seatbelt mounted in cab</li> <li><input type="checkbox"/> <b>PST-BENC</b> Bench passenger seat</li> <li><input type="checkbox"/> <b>PST-CF4</b> Passenger seat - Comfort suspended with seatbelt mounted in seat</li> <li><input type="checkbox"/> <b>PST-CF5</b> Passenger seat - Comfort suspended &amp; heated with seatbelt mounted in seat</li> <li><input type="checkbox"/> <b>PST-STD2</b> Passenger seat - Fixed non suspended with seatbelt mounted in cab</li> <li><input type="checkbox"/> <b>PST-STD4</b> Passenger seat - Standard suspended with seatbelt mounted in cab</li> <li><input type="checkbox"/> <b>SBPRE-PS</b> Passenger seat belt pretensioner</li> <li><input type="checkbox"/> <b>ARM-DBPS</b> Two armrests on driver seat and one (outer) on passenger seat</li> <li><input type="checkbox"/> <b>ARMRE-BB</b> Two armrests on both driver and passenger seat.</li> <li><input type="checkbox"/> <b>ARMRE-DB</b> Two armrests, on driver seat only</li> <li><input type="checkbox"/> <b>ARMRE-PB</b> Two armrests, on passenger seat only</li> <li><input type="checkbox"/> <b>ARMRE-PS</b> Single armrest (next to driver) on passenger seat</li> <li><input type="checkbox"/> <b>ARU-BAS</b> Vinyl upholstered armrest</li> <li><input type="checkbox"/> <b>ARU-LEA</b> Leather upholstered armrest</li> <li><input checked="" type="checkbox"/> <b>FMAT-RU2</b> Rubber floor mats, extended</li> <li><input type="checkbox"/> <b>FMAT-RUB</b> Rubber floor mats</li> <li><input type="checkbox"/> <b>FMAT-T2E</b></li> <li><input type="checkbox"/> <b>FMAT-TX2</b> Textile and rubber floor mats</li> <li><input type="checkbox"/> <b>LBK-RES</b> Foldable rest bunk</li> <li><input type="checkbox"/> <b>LBK70</b> Lower bunk 700 x2000 mm, fixed</li> <li><input checked="" type="checkbox"/> <b>ULBK</b> Without lower bunk</li> <li><input type="checkbox"/> <b>MATL-FI</b> Firm lower bunk pocket sprung mattress</li> <li><input type="checkbox"/> <b>MATL-SF</b> Lower flexizone mattress - semi-firm, pocket springs up to 100kg - 16 stone</li> <li><input type="checkbox"/> <b>MATL-SO</b> Lower flexizone mattress - soft, pocket springs up to 85kg - 13.5 stone</li> <li><input type="checkbox"/> <b>OLMAT-BA</b> 35mm mattress overlay protector</li> <li><input type="checkbox"/> <b>OLMAT-PR</b> 50mm premium mattress overlay protector</li> <li><input type="checkbox"/> <b>TBK60F</b> Fixed foldable top bunk 600 x 1900mm</li> <li><input type="checkbox"/> <b>TBK70F</b> Fixed foldable top bunk 700 x 1900mm</li> <li><input type="checkbox"/> <b>PH-CAB2</b> 1.8kW Air to air night heater</li> <li><input type="checkbox"/> <b>PH-ENGCA</b> Engine and cab night heater</li> <li><input type="checkbox"/> <b>PH-SS</b> Short stop heater</li> <li><input type="checkbox"/> <b>SLCP-BAS</b> Basic sleeper control panel - includes interior light, parking heater, roof hatch and door lock</li> <li><input type="checkbox"/> <b>SAFE</b> Safe box for driver's personal items</li> <li><input type="checkbox"/> <b>ETSB-F</b> Storage on engine tunnel - on front top</li> <li><input type="checkbox"/> <b>ETSB-FR</b> Storage on engine tunnel - on front top and at rear cab wall</li> <li><input type="checkbox"/> <b>ETSB-FRS</b> Storage on engine tunnel - on front top &amp; at rear cab wall &amp; storage recessed into tunnel on right hand side</li> <li><input type="checkbox"/> <b>ETSB-FS</b> Storage on engine tunnel - on front top and storage recessed</li> </ul> |
|--|---|

Standard Equipment

Optional Equipment

For more detailed information about cab and powertrain equipment, please refer to separate specification sheets.

For all possible options and combinations of options please consult your Volvo sales contact who can create a specification to match your requirements using the Volvo Sales Support system (VSS).

The factory reserves the right to modify design and change equipment without previous notification. The specification can vary from country to country.

# MODEL RANGE

## FMX13 6x4 Rigid - X-High Rear Air Suspension - N3G Straight front axle FM 64 R3CAX

- |   |   |   |   |
|---|---|---|---|
| <input type="checkbox"/> <b>ETSB-R</b>              | into tunnel on right hand side  | <input type="checkbox"/> <b>AD-ROOF</b>             | Roof air deflector  |
| <input type="checkbox"/> <b>ETSB-RS</b>             | Storage on engine tunnel - box at rear cab wall   | <input type="checkbox"/> <b>AD-SIDEL</b>            | Side air deflector extension panels   |
| <input type="checkbox"/> <b>ETSB-S</b>              | Storage on engine tunnel - recessed into tunnel on right hand side  | <input type="checkbox"/> <b>AD-SIDES</b>            | Short cab side air deflector for rigid bodywork   |
| <input type="checkbox"/> <b>RUS-BAS</b>             | Rear cab upper storage 154 litres - 300 mm high   | <input checked="" type="checkbox"/> <b>HL-BAS2</b>  | Halogen H1 head lamps   |
| <input type="checkbox"/> <b>RUS-HIG</b>             | Rear cab upper storage 245 litres - 440 mm high   | <input checked="" type="checkbox"/> <b>HL-BASIC</b> | Halogen H7 head lamps   |
| <input type="checkbox"/> <b>TABLE</b>               | Folding and height adjustable table - on lower bunk   | <input type="checkbox"/> <b>HL-BHID2</b>            | Dynamic high intensity Bi-Xenon head lamps<br>These follow the steering movement and direction of the truck   |
| <input type="checkbox"/> <b>REF-ICPK</b>            | Refrigerator preparation kit, engine tunnel mounted   | <input type="checkbox"/> <b>HL-CLEAN</b>            | Head lamp cleaner - washer jets   |
| <input type="checkbox"/> <b>REFR-RUS</b>            | 28 litre rear upper wall mounted refrigerator with dividers   | <input type="checkbox"/> <b>HLP-ST</b>              | Headlamp protection   |
| <input type="checkbox"/> <b>BOTH-D</b>              | One bottle holder under dashboard centre section  | <input type="checkbox"/> <b>HL-ADJ</b>              | Adjustable headlights with switch in the cab  |
| <input type="checkbox"/> <b>COFMA-PK</b>            | Coffee maker, preparation kit.  | <input checked="" type="checkbox"/> <b>UDRIVL</b>   | Without auxiliary driving lights  |
| <input checked="" type="checkbox"/> <b>INLI-BAS</b> | Basic white interior lights   | <input type="checkbox"/> <b>ASL-RF2</b>             | Two Hella H11 70W spotlamps in sign box - only available with the basic headlight and no lower driving lights.<br>Preparation kit for two spotlamps in sign box |
| <input type="checkbox"/> <b>INLI-NL</b>             | Interior white and red night light with no dimmer   | <input type="checkbox"/> <b>ASL-RFPK</b>            |   |
| <input type="checkbox"/> <b>INLI-NLD</b>            | Interior white and red night light with dimmer function   | <input type="checkbox"/> <b>BEACOA2F</b>            | Two front roof mounted amber beacon rotating warning lamps  |
| <input type="checkbox"/> <b>ARL-FLEX</b>            | Two flexible reading lamps (snake lamps)  | <input type="checkbox"/> <b>BEACOA2R</b>            | Two rear roof mounted (on accessory bracket) amber beacon flashing warning LED lamps  |
| <input type="checkbox"/> <b>RH-EE</b>               | Without roof hatch  | <input type="checkbox"/> <b>BEACON-P</b>            | Roof beacon wire preparation  |
| <input type="checkbox"/> <b>RH-ETR</b>              | Roof & escape hatch - Electrically operated, tinted glass with rear opening   | <input type="checkbox"/> <b>BEACONA4</b>            | Four roof mounted (2 front/2 rear) amber beacon rotating warning lamps  |
| <input type="checkbox"/> <b>RH-MSR</b>              | Steel roof hatch - Manually operated with rear opening  | <input type="checkbox"/> <b>CABPT-R1</b>            | Single outlet for roof mounted accessories  |
| <input type="checkbox"/> <b>RH-MTR</b>              | Roof & escape hatch - Manually operated, tinted glass with rear opening   | <input checked="" type="checkbox"/> <b>CABPT-R2</b> | Twin outlets for roof mounted accessories.  |
| <input checked="" type="checkbox"/> <b>URH</b>      | Without roof hatch  | <input type="checkbox"/> <b>SPOTP-F</b>             | Spotlamp preparation in front, max 280W   |
| <input type="checkbox"/> <b>SWIND-BS</b>            | Extra side window on both sides behind "B" pillar   | <input type="checkbox"/> <b>SPOTP-R</b>             | Spotlamp preparation on roof, max 280W  |
| <input type="checkbox"/> <b>SWIND-PS</b>            | Rear side window, passenger side  | <input type="checkbox"/> <b>SPOTP-RF</b>            | Spotlamp preparation on cab roof and in cab front, max 2x280W   |
| <input type="checkbox"/> <b>VANMIR</b>              | Vanity mirror in front shelf  | <input type="checkbox"/> <b>CSGN-FMX</b>            | "Volvo FMX" headboard logo  |
| <input type="checkbox"/> <b>AS-FUS</b>              | Extra shelf in front upper storage compartments   | <input checked="" type="checkbox"/> <b>HORN-F1S</b> | Single tone Jericho air horn chassis mounted  |
| <input type="checkbox"/> <b>INFOT-PK</b>            | Preparation kit for the mounting of a flat screen TV in cab above the driver's door, includes bracket, electrical and speaker connections | <input type="checkbox"/> <b>HORN-R2S</b>            | Two roof mounted air horns  |
- CAB EXTERIOR**
- |  |   |  |  |
|--|---|--|--|
| <input checked="" type="checkbox"/> <b>PAICS-B</b>   | Basic cab paint - mirrors, sunvisor, instep and bumper supplied in natural finish - grey                                      | <input type="checkbox"/> <b>ANT-CBR</b>  | Roof mounted antenna for CB radio, single aerial     |
| <input checked="" type="checkbox"/> <b>GLAS-TIN</b>  | Tinted windows.   | <input type="checkbox"/> <b>ACCBP-AP</b> | Front, middle & rear roof mounted accessory brackets |
| <input type="checkbox"/> <b>AWIND-RF</b>             | Rear window   | <input type="checkbox"/> <b>ACCBP-F</b>  | Front roof mounted accessory bracket                 |
| <input type="checkbox"/> <b>DGLAS-L</b>              | Laminated door glass  | <input type="checkbox"/> <b>ACCBP-FM</b> | Front & middle roof mounted accessory brackets       |
| <input checked="" type="checkbox"/> <b>LOCK-MAN</b>  | Manual door locking   | <input type="checkbox"/> <b>ACCBP-FR</b> | Front & rear roof mounted accessory brackets         |
| <input type="checkbox"/> <b>LOCK-MRP</b>             | Manual door locking with internal remote control (from driver side) of passenger door   | <input type="checkbox"/> <b>ACCBP-M</b>  | Middle roof mounted accessory bracket                |
| <input type="checkbox"/> <b>LOCK-REM</b>             | Central locking with remote control   | <input type="checkbox"/> <b>ACCBP-R</b>  | Rear roof mounted accessory bracket                  |
| <input checked="" type="checkbox"/> <b>BUMP-HD</b>   | Heavy duty front bumper   | <input type="checkbox"/> <b>ACCBP-RM</b> | Rear & middle roof mounted accessory brackets        |
| <input type="checkbox"/> <b>AUXFS</b>                | Lower swinging cab step   | <input type="checkbox"/> <b>REFS-CW</b>  | White cab conspicuity markings mounted on cab side   |
| <input type="checkbox"/> <b>GUARD-EH</b>             | Engine guard to protect sump and engine hoses   | <input type="checkbox"/> <b>REFS-TW</b>  | White cab conspicuity markings by packed in cab      |
| <input checked="" type="checkbox"/> <b>BUGNET</b>    | Insect screen in front of radiator  | <input type="checkbox"/> <b>REFS-TY</b>  | Yellow cab conspicuity markings by packed in cab     |
| <input type="checkbox"/> <b>CTILT-P-E</b>            | Electrically operated hydraulic cab tilt  |  |  |
| <input checked="" type="checkbox"/> <b>CTILT-P-M</b> | Manually operated hydraulic cab tilt  |  |  |
| <input type="checkbox"/> <b>FCABS-A</b>              | Front cab - Air suspension  |  |  |
| <input checked="" type="checkbox"/> <b>FCABS-M</b>   | Front cab - Mechanical spring suspension  |  |  |
| <input type="checkbox"/> <b>RCABS-A</b>              | Rear cab suspension - Air   |  |  |
| <input checked="" type="checkbox"/> <b>RCABS-M</b>   | Rear cab suspension - Mechanical spring   |  |  |
| <input type="checkbox"/> <b>MIRCOMFX</b>             | Electrically heated and operated exterior mirrors with wide angle mirror on both sides and kerb view mirror on passenger side |  |  |
| <input checked="" type="checkbox"/> <b>MIRSTDX</b>   | Electrically heated exterior mirrors with wide angle mirror on both sides and kerb view mirror on passenger side              |  |  |
| <input checked="" type="checkbox"/> <b>AMIR-F20</b>  | Auxiliary front view mirror with a 200mm radius   |  |  |
| <input type="checkbox"/> <b>SUNV-H</b>               | External smoke grey sunvisor  |  |  |
- Standard Equipment       Optional Equipment

### SUPERSTRUCTURE PREPARATIONS

- |  |  |
|--|--|
| <input type="checkbox"/> <b>BP-MI02</b>  |  |
| <input type="checkbox"/> <b>BP-TI03</b>  |  |
| <input type="checkbox"/> <b>SRWL-PK</b>  | Wiring preparation for side & rear work/reverse lamps on side of chassis and a three-position switch, maximum 280W |
| <input type="checkbox"/> <b>SWL-2FW</b>  | Two H3 70W white front chassis mounted (LH/RH side) working lamps and a 2-position switch (On/Off)                 |
| <input type="checkbox"/> <b>SWL-2RW</b>  | Two H3 70W white rear chassis mounted (LH/RH side) working lamps and a 2-position switch (On/Off)                  |
| <input type="checkbox"/> <b>SWL-4W</b>   | 4 H3 70W white front (2) & rear (2) chassis mtd (LH/RH side) working lamps & 2-pos switch (On/Off)                 |
| <input type="checkbox"/> <b>SWL-PK</b>   | Wiring preparation for side work/reverse lamps on side of chassis and a three-position switch, maximum 280W        |
| <input type="checkbox"/> <b>WLC-H2A</b>  | Two H3/70W working lamps with amber coloured lens high mounted back of cab   |
| <input type="checkbox"/> <b>WLC-H2W</b>  | Two H3/70W white working lamps high mounted on the back of cab   |
| <input type="checkbox"/> <b>WLC-PKCH</b> | Preparation kit (cables and switch) for cab mounted chassis working lamp   |
| <input type="checkbox"/> <b>WLC-PKH</b>  | Preparation kit, cables and switch for high mounted working lamps back of cab                                      |
| <input type="checkbox"/> <b>WLC-PKL</b>  | Preparation kit, cables and switch for low mounted working lamps back of cab                                       |
| <input type="checkbox"/> <b>WLC-PKLH</b> | Preparation kit - cables and switch for low and high mounted   |

For more detailed information about cab and powertrain equipment, please refer to separate specification sheets.

For all possible options and combinations of options please consult your Volvo sales contact who can create a specification to match your requirements using the Volvo Sales Support system (VSS).

The factory reserves the right to modify design and change equipment without previous notification. The specification can vary from country to country.

# MODEL RANGE

FMX13 6x4 Rigid - X-High Rear Air Suspension - N3G Straight front axle FM 64 R3CAX

---

working lamps back of cab.

- ECBB-BAS** Body builder electrical centre without body builder module
- ECBB-HIG** Body builder electrical centre with body builder module
- BBCHAS1** One 7-pole connector for Body builder interface
- BBCHAS3** Three 7-pole connectors for Body builder interface
- BEPR-T2** Body builder electrical software preparation for tipper with remote control
- EXSTER** External steering control, with VDS and bodybuilder module
- TD-BAS** Trailer detection WITHOUT LED sensing
- TD-LED** Trailer detection with LED sensing
- FRFS-BS** Frame rail free space on both sides to give space for crane legs or other equipment.
- FBA-BTF** Lower front body attachments for torsionally flexible - platform body
- FBA-BTSF** Lower front body attachments for torsionally semi-flexible body - box or curtainsider
- HBA-FSFB** Holes for body attachments - flexible/semi-flexible body
- HBA-SB** Holes for body attachments - stiff body
- RBA-T2** Lower rear body attachments for helper frame
- CRANEPK1** Crane plates mounted to frame, for cranes up to 10 tonne metre capacity
- CRANEPK2** Crane plates mounted to frame, for cranes up to 20 tonne metre capacity
- CRANEPK4** Crane plates mounted to frame, for cranes up to 40 tonne metre capacity
- AUXL-SPK** Electrical preparation kit - wiring and switch for snow plough lights
- TAILPRE2** Tail lift preparation kit, wireless remote operation
- TAILPREP** Taillift preparation kit - cab switch and warning in driver display
- AESW2** Two Body builder bistable electrical switches (marked AUX1 / AUX2)
- AESW2PK** 2 Body builder bistable el.switches (marked AUX1/AUX2) and prep. for 4 more switches
- AUXSW-4** Wiring for 4 extra switches (from Body builder electrical centre to switch positions)

## DELIVERY SERVICES

- TGW-3GWL** Telematics gateway with GSM/GPRS/3G modem and wireless lan WLAN
- FMS-PK** Fleet Management System gateway
- DRUT** "My Truck App" Two years subscription to driver utility application

**VOLVO**

Volvo Truck Corporation  
volvotrucks.com