

MODEL RANGE

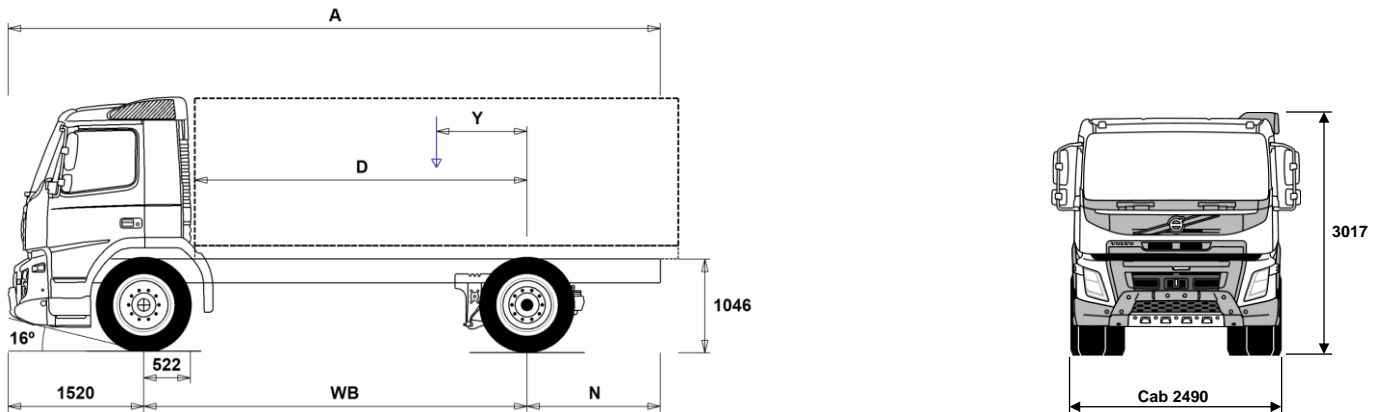

Volvo Trucks. Driving Progress

FMX13 4x2 Platform - Rear Air Suspension FM 42 R3HAX



Chassis Dimensions [mm]

WB Wheelbase	3400	3700	4000	4300	4600	4900	5200	5600	6000	6300	6500	6700
A Overall Chassis Length	6815	7265	7665	8165	8665	9115	9615	10215	10815	11365	11715	11965
D Center of rear axle to front of body	2828	3128	3428	3728	4028	4328	4628	5028	5428	5728	5928	6128
N Rear Overhang (Min.)	1395	1395	1395	1395	1395	1395	1395	1395	1395	1395	1395	1395
N Rear Overhang (Max.)	1895	2045	2145	2345	2545	2695	2895	3095	3295	3545	3695	3745
Y Center of Gravity for Payload (Min.)	575	623	671	718	765	813	862	924	985	1040	1074	1105
Y Center of Gravity for Payload (Max.)	752	816	880	944	1008	1072	1138	1223	1306	1378	1423	1465

Chassis Weights [kg]

Front Axle	4605	4615	4620	4640	4650	4660	4665	4680	4695	4685	4685	4690
Rear Axle	1850	1870	1890	1935	1975	1995	2025	2065	2100	2125	2145	2155
Kerb Weight	6455	6485	6510	6575	6625	6655	6690	6745	6795	6810	6830	6845
Payload (including body, driver, fuel, etc.)	11545	11515	11490	11425	11375	11345	11310	11255	11205	11190	11170	11155

Turning Diameter [mm]

Turning Circle Diameter Kerb to Kerb	12400	13400	14300	15200	16100	17000	17900	19200	20400	21300	21900	22500
Turning Circle Diameter Wall to Wall	13900	14800	15800	16700	17600	18500	19400	20700	21900	22800	23400	24000

Plated Weights [kg]

	Plated	Design
Gross Vehicle Weight	18000	20100
Gross Combination Weight	40000	44000
Front Axle	7100	7100
Rear Axle	11500	13000

Important Notes

Chassis Dimensions

Cab Height: +416 mm for CAB-HSLP, +554 mm for CAB-XHSL.
Front Axle to Back of Cab: +424 mm for CAB-HSLP and CAB-SLP and CAB-XHSL.

D-measure includes a front clearance of 50 mm and for rigid trucks also a subframe of 100 mm.

Height can vary ± 20 mm for leaf and ± 10 mm for air suspension.

All dimensions are for unladen chassis and any tag axles down. Chassis height used: CHH-HIGH.

Rear overhang used for vehicle weight calculation is the maximum rear overhang (N Max.) for selected wheelbase.

Height change when chassis height CHH-MED, FRAME266: 0 mm.

Weight and dimensions are based upon the following tyres:

Front Axle Tyres:	315/80R22.5
Drive Axle Tyres:	315/80R22.5

Chassis weight includes oil, water, AdBlue, 0 litres fuel and without driver. Kerb weight can vary $\pm 3\%$.

Turning diameters are theoretically calculated.

Legal weights can differ from country to country.

For more detailed weight information, including optional equipment weights, ask your Volvo sales contact to enter your specification into the Volvo Weight Information system (WIS).

Do NOT use this drawing for bodybuilding. Refer to Volvo Bodybuilder Instructions and chassis assembly drawing FM42R3HAX.

MODEL RANGE

FMX13 4x2 Platform - Rear Air Suspension FM 42 R3HAX

TRUCK USE

- RC-ROUGH** Operating class on/off road
- RC-SMOOT** Operating class highway
- GARB-PRE** Garbage preparation
- TIPP-PRE** Tipper vehicle preparation
- UNIFORM** Basic platform vehicle

CORE COMPONENTS

- CHH-HIGH** Chassis height standard - For a specific loading height always check the unique BEP chassis drawing
- CHH-MED** Chassis height medium - For a specific loading height always check the unique BEP chassis drawing
- RAD-GR** Rear air suspension, 1 axle - 1 driven
- FMX-DAY** Day cab - with steel safety cage design
Designed and built to Swedish impact and ECE R29 regulations
- FMX-HSLP** Globetrotter cab - with steel safety cage design
Designed and built to Swedish impact and ECE R29 regulations
- FMX-SLP** Sleeper cab - with steel safety cage design
Designed and built to Swedish impact and ECE R29 regulations
- EU6SCR** Emission level - Euro 6
- D13K420** D13K420 12.8l engine developing 420hp at 14-1800rpm.
Peak torque 2100Nm at 860 -1400rpm.
- D13K460** D13K460 12.8l engine developing 460hp at 14-1800rpm.
Peak torque 2300Nm at 900-1400rpm.
- D13K500** D13K500 12.8l engine developing 500hp at 14-1800rpm.
Peak torque 2500Nm at 1000-1400rpm.
- D13K540** D13K540 12.8l engine developing 540hp at 14-1800rpm.
Peak torque 2600Nm at 1000-1450rpm.
- EBR-EPG** Exhaust brake controlled by steering column switch
- EBR-EPGC** Exhaust pressure governor for I shift gearbox
- EBR-VEB+** Volvo engine brake + and exhaust pressure governor, enhanced performance from additional exhaust rocker control. Retardation 375kW
- AT2412F** AT2412F 12-speed "I-shift" automated mechanical gearbox suitable for gross train weights up to 44tonne only refer to sales engineering when used in conjunction with a PTO
- AT2612F** AT2612F 12-speed "I-shift" automated mechanical gearbox suitable for gross train weights up to 60tonne only refer to sales engineering when used in conjunction with a PTO
- ATO2612F** ATO2612F 12-speed "I-shift" overdrive automated mechanical gearbox suitable for gross train weights up to 60tonne refer to sales engineering when used in conjunction with a PTO
- PT2606** Powertronic automatic 6-speed gearbox, max. engine torque 2600 Nm, max. permitted GCW 130000 kg
- SPO2812** SPO2812 - 12 speed I-shift Dual Clutch automated mechanical gearbox GCW 60tonne
- RSH1370F** RSH1370F hub reduction rear axle with differential lock - design GCW 70 tonne
- RSS1344D** RS1344D single reduction rear axle with differential lock - design GCW 44tonne
- RSS1356** RSS1356 single reduction rear axle with differential lock - design GCW 56 tonne
- RSS1360** RSS1360 single reduction rear axle with differential lock - design GCW 60 tonne

PACKAGES

- DRIVEFM** Driving package
- DRIVEFM+** Driving plus package
- BEDFM** One bed resting package
- AUDHIG** High Power Audio system: RDS radio with CD player - also playing MP3/WMA files from CD -, with integrated bluetooth phone and USB/Line inputs. FM/AM antenna, speakers in

Standard Equipment

Optional Equipment

For more detailed information about cab and powertrain equipment, please refer to separate specification sheets.

For all possible options and combinations of options please consult your Volvo sales contact who can create a specification to match your requirements using the Volvo Sales Support system (VSS).

The factory reserves the right to modify design and change equipment without previous notification. The specification can vary from country to country.

- MEDIA** dashboard, doors, and sleeping compartment.
AM/FM Bluetooth radio without CD player.
USB and Aux line inputs.
Speakers in dashboard, doors, and sleeping compartment.
7" touch screen with personal apps.
 - MEDIADF** AM/FM Bluetooth radio without CD player.
USB and Aux line inputs.
Speakers in dashboard, doors, and sleeping compartment.
7" touch screen with personal and professional apps.
Dynafleet vehicle on-board data display with office internet support.
 - MEDIANAV** AM/FM Bluetooth radio without CD player.
USB and Aux line inputs.
Speakers in dashboard, doors, and sleeping compartment.
7" touch screen with personal and professional apps.
Truck based satellite navigation (live updates not included)
 - MEDIANDF** AM/FM Bluetooth radio without CD player.
USB and Aux line inputs.
Speakers in dashboard, doors, and sleeping compartment.
7" touch screen with personal and professional apps.
Truck based satellite navigation (live updates not included)
Dynafleet vehicle on-board data display with office internet support.
 - VISIX15** Visibility package
 - ASAF15** New Active safety package
 - RCHAPAC1** Chassis Package Rigid
- ### CHASSIS
- FST-AIR** Front suspension type - air
 - FST-PAR** Front suspension type - 2 leaf parabolic springs
 - FST-PAR3** Front suspension type - 3 leaf parabolic springs
 - FAL10.0** Front axle design capacity 10 tonnes - Ensure that you have checked the tyre load index
 - FAL7.1** Front axle design capacity 7.1 tonnes
 - FAL7.5** Front axle design capacity 7.5 tonnes
 - FAL8.0** Front axle design capacity 8.0 tonnes - Ensure that you have checked the tyre load index
 - FAL8.5** Front axle design capacity 8.5 tonnes
 - FAL9.0** Front axle design capacity 9.0 tonnes - Ensure that you have checked the tyre load index
 - FSM-LUB** Lubricated rear shackles on front suspension pins and bushings
 - FSTAB** Front anti-roll bar
 - FSTAB2** Front anti-roll bar medium stiffness
 - FSTAB3** Front stiff anti-roll bar
 - RAL13** Rear axle design capacity 13 tonnes
 - RSTAB3** Rear stiff anti-roll bar
 - ASF-DL1** Air suspension with 1 driving level
 - ASF-DL3** Air suspension with 3 driving levels
 - ACTST-TO** Volvo Dynamic Steering (VDS) with with extra electronic pump and torque overlay
 - ASFE-BAS** Active steering feature - Basic - Volvo Dynamic Steering only
 - ASFE-PS** Active steering feature - Volvo Dynamic Steering with personal settings
 - PSS-SING** Single power steering system
 - PSP-FIX** Power steering pump with fixed displacement
 - PSP-VAR** Power steering pump with variable displacement
 - EBS-MED** EBS medium package including "hill" hold function
 - AUXPARK** Additional spring parking brakes
 - ABS** Anti lock brakes
 - FBREG-E** Front regulating brake valve, EBS
 - SUSPL-EC** Remote electronic control on wander-lead for air suspension levelling
 - FRAME266** Frame rail section external height 266 mm

MODEL RANGE

FMX13 4x2 Platform - Rear Air Suspension FM 42 R3HAX

- FRAME300** Frame rail section external height 300 mm
- FST6060** Frame thickness - web and flange 6.0mm
- FST7070** Frame thickness - web and flange 7.0mm
- FST8080** Frame thickness - web and flange 8.0mm
- FIL-EEEB** Inner liner from end of engine to end of bogie
- FIL-EEEF** Inner liner from end of engine to end of frame
- FIL-TXEB** Inner liner from gearbox member to end of bogie
- FIL-TXEF** Inner liner from gearbox member to end of frame
- BBOX-L** Battery box located on left hand side
- BATS-D** Dual energy battery system - 2 living batteries and 2 starter batteries.
- BATS-S** Single energy battery system (2 batteries)
- 2BAT210B** 2 x 210 Ah capacity Gel batteries
- 2BATT170** 2 x 170 Ah capacity batteries
- 2BATT225** 2 x 225 Ah capacity batteries
- BATTAMP** Battery voltage and ampere gauge
- BATTIND** Battery charge indication
- ADR2** ADR package for transportation of dangerous goods on road (Note does NOT include safe loading pass package if required this is quoted separately)
- MSWI-A** Main switch - ADR switch circuit shut down
- MSWI-C** Main switch - Chassis mounted toggle switch by battery box
- MSWI-R** Main switch - Key fob operated remote controlled
- R330A71** Right aluminium 710 mm D-shaped fuel tank, 330 litres volume
Min volume 255l
Max volume 885l
- UL-FUEL** Without left fuel tank
Min volume 160l
Max volume 730l
- ADTP-L** AdBlue tank on left hand side
- ADTP-R** AdBlue tank on right hand side
- ADB048** AdBlue tank usable volume 48 litres
- ADB064** AdBlue tank usable volume 64 litres
- ADB068** AdBlue tank usable volume 68 litres
- ADB090** AdBlue tank usable volume 90 litres
- ADB100** AdBlue tank usable volume 100 litres
- ADTC-BF** AdBlue tank cover with satin alloy look decorative cover
- FCAP-L** Locking fuel filler cap
- FUFF-AS** Fuel filling anti-spillage device
- FUFF-ATS** Fuel filling anti-theft and anti-spillage devices
- ESH-LEFT** Horizontal silencer, left exhaust outlet
- ESH-REAR** Horizontal silencer, rear exhaust outlet
- ESH-RIGH** Horizontal silencer, right exhaust outlet
- ESH-VERT** Horizontal silencer, vertical exhaust outlet
- EXST-SSP** Stainless steel exhaust stack - NOT polished
- EXST-ST** Steel exhaust stack
- HS-NAR** Narrow heat shield
- WHC-FIX1** One fixed wheel chock
- WHC-FIX2** Two fixed wheel chocks
- WHC-FOL1** One foldable wheel chock
- WHC-FOL2** Two foldable wheel chocks
- WHCP-F** Wheel chock(s) stored in the front part of the vehicle
- WHCP-M** Wheel chock(s) stored in the middle part of the vehicle
- WHCP-R** Wheel chock(s) stored in the rear part of the vehicle
- WHCP-T** Transport mounted wheel chock(s) stored in cab outer luggage locker
- TB-R80** Toolbox 800 mm, right side
- SUP-BAS** EC approved chassis side guards
- CHAIN-S** Snow chains
- HOOK-SC** Snow chain hooks
- TOWF-HD1** One heavy duty front towing device
- TOWMBRH** Towing member, high mounted in centre of frame, D = 190
- TOWMBRL1** Towing member, low mounted under the frame
- TOWMBRL2** Towing member, low and forward mounted under the frame
- TOWMBRL3** Towing member, low and far forward mounted under the frame
- TOWMBRM** Towing member, medium mounted in line with frame lower flange
- RFEC-L** Rear frame end, lower flange cut for centre axle drawbar.
- RFEC-S** Rear frame end, straight cut for regular platform applications
- RFEC-U** Rear frame end, upper cut for tipper applications.
- C-RI4040** Towing coupling, Ringfeder 4040 G-150
- C-RI5055** Towing coupling, Ringfeder 5055 G-150
- C-RO400G** Towing coupling, Rockinger 400 G-150 for 40mm eyes
- C-RO50** Rockinger RO 50 50mm for centre axle trailer
- TOWR-ONE** Towing hitch attached to rear crossmember
- TREL-PK** Trailer electrical preparation kit - chassis/cab wiring
- TREL14** Single 14 pole electrical trailer connector
- TREL15** Single 15 pole electrical trailer connector - ADR certified
- TREL7** 7 pole - 24N trailer electrical suzie
- TREL7-7** 24N and 24S trailer electrical suzies
- TBC-DUO** Duomatic type air line connectors
- TBC-EC** Palm coupling type air line connectors
- TRBR-HCF** Full pressure hand controlled trailer brake
- TRBR-STA** Stationary trailer brake control
- TRB-STRE** Stretch Brake - Automatic low speed trailer brake activation to avoid jack-knifing and improve steerability
- RUP-FOLD** Folding EC approved aluminium rear underrun
- RUP-FOSL** Folding & sliding EC approved aluminium rear underrun
- RFEND-B** Three piece EC approved rear mud wings and spray flaps
- RFEND-T** Rear mud wings, transport mounted
- RFH-BAS** Basic rear wing height
- RFH-HIG** High rear wing height - higher wing tops
- RFH-LOW** Lower rear wing height - shallower wing tops
- ATANK-AL** Aluminium air tanks
- ATANK-ST** Steel air tanks
- TL-LED** LED Tail lights
- BLIGHT-E** Emergency brake light

WHEELS & TYRES

- RT-AL** Alcoa brushed aluminium rims with standard holes for long stud fixing on all axles
- RT-ALDP** Alcoa Dura-Bright EVO aluminium rims with standard holes long stud fixing on all axles, requires cleaning with a ph neutral solution - washing up liquid.
- RT-ALDPD** Alcoa Dura-Bright EVO aluminium rims with countersunk holes for short stud fixing on all axles, requires cleaning with a ph neutral solution - washing up liquid.
- RT-ALDU** Alcoa brushed aluminium rims with countersunk holes for short stud fixing on all axles
- RT-STEEL** Steel rims on all axles
- WCAP** Aerodynamic hub caps
- BRREC001** Bridgestone ECOPIA H - Energy rating C
- COREC001** Continental ECOPLUS HS3 XL/HD3 - Energy rating B or C depending on size
- COREC002** Continental ECOPLUS HS3/HD3 - Energy rating B or C depending on size
- COREC003** Continental Efficient Pro S/D - Fuel Tyre Recommendation 3 Reduced mileage compared to Conti EcoPlus long haul pattern please consider when selecting these tyres.
- GYREC001** Good Year FUELMAX S/HL/D - Energy rating B or C depending on size
- GYREC002** Good Year FUELMAX S/D - Energy rating B or C depending on size
- GYREC003** Good Year FUELMAX S/(O)/D - Fuel tyre Recommendation 3
- MIREC001** Michelin XFA2/X-LINE Energy - Fuel tyre Recommendation 1
- MIREC002** Michelin XZA2/X-LINE Energy - Fuel tyre Recommendation 2
- MIREC003** Michelin X-LINE Energy - Fuel tyre Recommendation 3

Standard Equipment Optional Equipment

For more detailed information about cab and powertrain equipment, please refer to separate specification sheets.

For all possible options and combinations of options please consult your Volvo sales contact who can create a specification to match your requirements using the Volvo Sales Support system (VSS).

The factory reserves the right to modify design and change equipment without previous notification. The specification can vary from country to country.

MODEL RANGE

FMX13 4x2 Platform - Rear Air Suspension FM 42 R3HAX

<input type="checkbox"/> MIREC004	Michelin X Line Energy F/D2 - Energy rating A	<input type="checkbox"/> EST-AID	Air inlet manifold starting heater element
<input type="checkbox"/> SPWT-D	Spare wheel & tyre with rear tyre pattern	<input type="checkbox"/> 220EBH15	220V/1.5Kw electric engine block heater
<input type="checkbox"/> SPWT-F	Spare wheel & tyre with front tyre pattern	<input type="checkbox"/> PTER-100	Rear engine mounted power-take-off with DIN 100 / ISO 7646 flange
<input type="checkbox"/> SWCP-LF	Spare wheel carrier on left side of chassis ahead of rear axle	<input type="checkbox"/> PTER-DIN	Rear engine mounted PTO with DIN5462 (female) splined shaft for a close coupled pump. Models with 3 steering axles will use this to drive the steering pump (AUXPSP)
<input type="checkbox"/> SWCP-R	Rear mounted spare wheel carrier	<input type="checkbox"/> PTER1400	Rear engine mounted power-take-off with SAE 1410 flange
<input type="checkbox"/> SWCP-T	Spare wheel supplied temporarily strapped to chassis	<input type="checkbox"/> HPE-F101	Parker F1-101, engine mounted, fixed displacement, single flow, engine mounted hydraulic pump
<input type="checkbox"/> SWCP-TP	Temporary spare wheel carrier on top of chassis frame	<input type="checkbox"/> HPE-F41	Parker F1-41, engine mounted, fixed displacement, single flow, engine mounted hydraulic pump
<input type="checkbox"/> JACK-12T	12 tonne bottle jack	<input type="checkbox"/> HPE-F51	Parker F1-51, engine mounted, fixed displacement, single flow, engine mounted hydraulic pump
<input type="checkbox"/> JACK-15T	15 tonne bottle jack	<input type="checkbox"/> HPE-F61	Parker F1-61, engine mounted, fixed displacement, single flow, engine mounted hydraulic pump
<input type="checkbox"/> JACK-20T	20 tonne bottle jack	<input type="checkbox"/> HPE-F81	Parker F1-81, engine mounted, fixed displacement, single flow, engine mounted hydraulic pump
<input checked="" type="checkbox"/> TOOL-BAS	Basic Toolkit	<input type="checkbox"/> HPE-T53	Parker F2-53/53, engine mounted, Fixed displacement, Twin flow engine mounted hydraulic pump
<input type="checkbox"/> TOOLKIT	Complete tool kit	<input type="checkbox"/> HPE-T70	Parker F2-70/35, engine mounted, Fixed displacement, Twin flow engine mounted hydraulic pump
<input type="checkbox"/> INFLAHOS	Tyre inflation hose	<input type="checkbox"/> HPE-V45	Parker VP1-45, variable displacement, single flow, engine mounted hydraulic pump
<input type="checkbox"/> GAUGE-TP	Tyre pressure gauge	<input type="checkbox"/> HPE-V75	Parker VP1-75, variable displacement, single flow, engine mounted hydraulic pump
<input type="checkbox"/> OBDEP-C	Euro 6 Step C emission level	<input type="checkbox"/> PTPT-D	Powertronic PTO, 1 front/upper DIN connection for plug-in pump (max. 850 Nm)
<input type="checkbox"/> OBDEP-D	Euro 6 Step D emission level	<input type="checkbox"/> PTPT-F	Powertronic PTO, 1 front/upper rear facing SAE flange conn. for prop shaft (max.850 Nm)
DRIVELINE EQUIPMENT		<input type="checkbox"/> PTR-D	Gearbox PTO for plug-in pump, 0.71xeng speed
<input type="checkbox"/> ASO-C	Crawler gear - Ratio direct top gearbox 19:1 Ratio Overdrive gearbox 17:1	<input type="checkbox"/> PTR-DH	Gearbox driven high speed PTO for one plug-in hydraulic pump
<input type="checkbox"/> ASO-ULC	Ultra low crawler and crawler gear - Ratios direct top gearbox 32:1 and 19:1 Ratios Overdrive box 32:1 and 17:1	<input type="checkbox"/> PTR-DM	Gearbox driven medium speed PTO for one plug-in hydraulic pump
<input type="checkbox"/> TRAP-HD	Reinforced gearbox application	<input type="checkbox"/> PTR-F	Gearbox driven PTO with rear flange connection
<input type="checkbox"/> TP-CON	Construction Package	<input type="checkbox"/> PTR-FH	Gearbox driven high speed PTO with SAE drive flange
<input type="checkbox"/> TP-DIST	Distribution Package	<input type="checkbox"/> PTR-FL	Gearbox driven low speed PTO with SAE drive flange
<input type="checkbox"/> TP-LONG	Long Haul Package	<input type="checkbox"/> PTRD-D	Gearbox driven HIGH SPEED PTO for two plug-in hydraulic pumps
<input type="checkbox"/> AMSO-AUT	Enhanced I-shift software with manual shift available in auto mode and kickdown facility on accelerator pedal	<input type="checkbox"/> PTRD-D1	PTRD-D1 Gearbox driven HIGH SPEED PTO (1 SAE flange & 1 plug-in hydraulic pump)
<input type="checkbox"/> AVO-ENH	Enhanced software for off road driveability and starting	<input type="checkbox"/> PTRD-D2	Gearbox driven HIGH SPEED PTO (2 SAE flanges & 1 plug-in hyd pump)
<input type="checkbox"/> APF-ENH	I-shift enhanced PTO functions	<input type="checkbox"/> PTRD-F	PTO with 1 DIN + 1 flange connection rear, manual gearbox
<input type="checkbox"/> CD43-O	Dual plate clutch, plate diameter 430 mm	<input type="checkbox"/> HPG-F101	Parker F1-101 gearbox mounted, fixed displacement, single flow, hydraulic pump
<input checked="" type="checkbox"/> CS43B-O	Single plate 430mm (17") clutch	<input type="checkbox"/> HPG-F41	Parker F1-41 gearbox mounted, fixed displacement, single flow, hydraulic pump
<input type="checkbox"/> RET-TH	Gearbox mounted retarder	<input type="checkbox"/> HPG-F51	Parker F1-51 gearbox mounted, fixed displacement, single flow, hydraulic pump
<input type="checkbox"/> RET-TPT	Hydraulic Retarder for Powertronic gearbox	<input type="checkbox"/> HPG-F61	Parker F1-61 gearbox mounted, fixed displacement, single flow, hydraulic pump
<input type="checkbox"/> TC-HWO	Automatic gearbox oil cooler - water to oil	<input type="checkbox"/> HPG-F81	Parker F1-81 gearbox mounted, fixed displacement, single flow, hydraulic pump
<input type="checkbox"/> TC-MAOH2	Extra high performance transmission oil cooler - air to oil with front mounted radiator	<input type="checkbox"/> EIDLESD	Engine idle shut down
<input type="checkbox"/> TC-MWO	Basic transmission oil cooler - water to oil	<input type="checkbox"/> STWPOS-L	LEFT HAND DRIVE
<input type="checkbox"/> TC-MWOH2	High performance transmission oil cooler - water to oil	<input checked="" type="checkbox"/> STWPOS-R	RIGHT HAND DRIVE
<input type="checkbox"/> 1COMP530	Single cylinder, air compressor, 530 litres per minute	<input type="checkbox"/> STWM-LE	Leather steering wheel
<input type="checkbox"/> 2COM1100	Two cylinder, air compressor, 1100 litres per minute	<input type="checkbox"/> STGW-AD2	Adjustable steering wheel with neck tilt
<input checked="" type="checkbox"/> 2COMP900	Two cylinder, air compressor, 900 litres per minute	<input checked="" type="checkbox"/> STGW-ADJ	Adjustable steering wheel
<input type="checkbox"/> CLU-AIRC	Clutchable air compressor	<input checked="" type="checkbox"/> AIRBAG	SRS Driver's air bag
<input checked="" type="checkbox"/> AIRIN-HI	Roof mounted air intake behind cab on left hand side	<input checked="" type="checkbox"/> DRC-AMII	DPF Regeneration control switch - for manual and switching off regeneration
<input type="checkbox"/> AIRIN-LO	Low level air intake behind cab on left hand side	<input type="checkbox"/> 1DAYDIG	Continental VDO DTCO 3.0 digital tachograph This tachograph can ONLY offer remote download if the option of Dynafleet or an FMS gateway has been specified with this
<input type="checkbox"/> ACL1ST-S	Two stage air filter		
<input checked="" type="checkbox"/> 24AL110B	110 amp alternator		
<input type="checkbox"/> 24AL120B	120 amp alternator		
<input type="checkbox"/> 24AL150B	150 amp alternator		
<input checked="" type="checkbox"/> CCV-C	Closed crankcase engine ventilation		
<input type="checkbox"/> CCV-O	Open crankcase engine breather		
<input type="checkbox"/> CCV-OX	Closed crankcase ventilation for cold markets		
<input checked="" type="checkbox"/> PRIM-EL	Electrical priming pump		
<input type="checkbox"/> PRIM-MAN	Manual priming pump		
<input type="checkbox"/> FUEQ-EH	Fuel line electric heater		
<input type="checkbox"/> AF-R	Hot fuel recirculation heated fuel filter		
<input type="checkbox"/> FUEFE2LW	Large engine mounted dual fuel filter with water separator		
<input checked="" type="checkbox"/> FUEFE2SW	Small engine mounted dual fuel filter with water separator		

Standard Equipment

Optional Equipment

For more detailed information about cab and powertrain equipment, please refer to separate specification sheets.

For all possible options and combinations of options please consult your Volvo sales contact who can create a specification to match your requirements using the Volvo Sales Support system (VSS).

The factory reserves the right to modify design and change equipment without previous notification. The specification can vary from country to country.

MODEL RANGE

FMX13 4x2 Platform - Rear Air Suspension FM 42 R3HAX

- | | |
|--|--|
| <ul style="list-style-type: none"> ■ 1DAYDIG2 order.
Continental VDO DTCO 4.0 smart tachograph
This tachograph can ONLY offer remote download if the option of Dynafleet or an FMS gateway has been specified with this order. □ 1DAYDIGP Continental VDO DTCO 3.0 digital tachograph
For vehicles with long lead time - this includes prep kit for the retrofit of DTCO 4.0 tachograph.
For updating to new legal demand for trick registration from 15th June 2019.
This tachograph can ONLY offer remote download if the option of Dynafleet or an FMS gateway has been specified with this order. □ ARSL Additional road speed limit - switch in dashboard □ SPEED-DU Dual speed limiter □ CRUIS-E Eco cruise control (with eco-roll and I-cruise, controls in steering wheel) ■ CRUISEC Cruise control, standard ■ ESP-BAS1 Electronic Stability Control □ ESPC-RO ESP (Electronic Stability Program) functionality control - Reduced / Off □ HWSS-ACB Adaptive cruise control with forward collision warning and advanced emergency braking ■ HWSS-FCB Forward collision warning with basic cruise control and advanced emergency brake ■ LSS-DW Lane departure warning system □ LCS Lane change support □ DAS-W Driver Alert Support system □ RSENS-W Rain sensing windscreen wipers □ CU-ECC Electrically controlled air conditioning with sun sensor □ CU-ECC2 Electrically controlled air conditioning with sun sensor, mist sensor, air quality sensor and carbon filter ■ CU-MCC Climate unit with manual controlled air conditioning ■ IMMOBIL Thatcham H2 approved immobiliser □ ALARM-B Thatcham H1 approved vehicle alarm - Cab only □ ALARM-E Enhanced vehicle alarm - Thatcham H1 approved - Cab plus external sensor for body/trailer □ ALCOLOCK Alcolock □ PHONE-PK Telephone preparation kit (antenna, antenna attachm. cable incl.) □ WLIFT-AD Electrical window lift, automatic up/down driver side ■ WLIFT-EB Electrical window lift □ WLIFT-ME Mechanical window lift □ ISUNS-BS Side interior sun visor on both sides ■ ISUNS-DS Driver's side interior sun visor ■ ISUNF-B Interior front sun visor without mirror □ ISUNF-MD Interior front sun visor with mirror on driver side □ ISUNF-RE Electrically operated textile interior sun blind □ ISUNF-RM Manually operated textile interior sun blind □ ADFS Two extra DIN slots in front shelf - can be fitted with card or drawer available as an accessory ■ BUPALARM Reverse alarm □ BUPMON Back up monitor with built in 7" screen on dash and one colour camera supplied loose for fitment by bodybuilder. □ RTOLL-PK Road toll PREPARATION kit for trucks operating with "Toll Collect" in Germany □ LOADIND Load indicator with central dashboard display □ REMC-MF Multi-functio wireless remote control □ FIREXT3S 3kg fire extinguisher mounted on seat base | <ul style="list-style-type: none"> □ WARNVEST High visibility warning vest - no sleeves □ AIDKIT First aid kit □ AIDKIT1B First aid kit □ WARNLAMP Portable warning lamp □ LAMP-IN Inspection lamp □ BULBKIT Bulb and fuse kit □ WRITEPAD Writing pad □ UPHTRI10 Seats: Black embossed textile insert with light grey sides, black vinyl side bolster with blue vinyl side insert.
Interior trim: Raven black bunk and curtains & blue textile side walls ■ UPHTRI11 Seats: Light grey embossed textile insert, black raven metallic vinyl bolster with red vinyl side insert.
Interior trim: Raven black bunk and curtains & grey vinyl side walls □ UPHTRI12 Seats: Blue soft textile insert, black vinyl bolster.
Interior trim: Raven black bunk and curtains & blue textile side walls □ UPHTRI13 Seats: Dark grey leather insert and black leather bolster.
Interior trim: Raven black bunk and curtains & grey vinyl side walls □ UPHTRI14 Seat: Dark grey leather insert and black leather bolster.
Interior trim: Raven black bunk and curtains & blue textile side walls ■ DST-CF4 Driver seat, comfort, suspended, belt in seat □ DST-CF5 Driver seat, comfort, suspended, belt in seat, electrically heated □ DST-CF6 Driver seat, comfort, suspended, belt in seat, electrically heated, ventilated □ SBD-RED Red seat belts □ SBPRE-DS Driver seat belt pretensioner ■ PST-BAS1 Passenger seat - Fixed non suspended fold up with seatbelt mounted in cab □ PST-BENC Bench passenger seat □ PST-CF4 Passenger seat - Comfort suspended with seatbelt mounted in seat □ PST-CF5 Passenger seat - Comfort suspended & heated with seatbelt mounted in seat □ PST-STD2 Passenger seat - Fixed non suspended with seatbelt mounted in cab □ PST-STD4 Passenger seat - Standard suspended with seatbelt mounted in cab □ SBPRE-PS Passenger seat belt pretensioner □ ARM-DBPS Two armrests on driver seat and one (outer) on passenger seat □ ARMRE-BB Two armrests on both driver and passenger seat. □ ARMRE-DB Two armrests, on driver seat only □ ARMRE-PB Two armrests, on passenger seat only □ ARMRE-PS Single armrest (next to driver) on passenger seat □ ARU-BAS Vinyl upholstered armrest □ ARU-LEA Leather upholstered armrest ■ FMAT-RU2 Rubber floor mats, extended □ FMAT-RUB Rubber floor mats □ FMAT-T2E □ FMAT-TX2 Textile and rubber floor mats □ LBK-RES Foldable rest bunk □ LBK70 Lower bunk 700 x2000 mm, fixed ■ ULBK Without lower bunk □ MATL-FI Firm lower bunk pocket sprung mattress □ MATL-SF Lower flexizone mattress - semi-firm, pocket springs up to 100kg - 16 stone □ MATL-SO Lower flexizone mattress - soft, pocket springs up to 85kg - 13.5 stone □ OLMAT-BA 35mm mattress overlay protector □ OLMAT-PR 50mm premium mattress overlay protector |
|--|--|
- Standard Equipment □ Optional Equipment

For more detailed information about cab and powertrain equipment, please refer to separate specification sheets.

For all possible options and combinations of options please consult your Volvo sales contact who can create a specification to match your requirements using the Volvo Sales Support system (VSS).

The factory reserves the right to modify design and change equipment without previous notification. The specification can vary from country to country.

MODEL RANGE

FMX13 4x2 Platform - Rear Air Suspension FM 42 R3HAX

- TBK60F** Fixed foldable top bunk 600 x 1900mm
 - TBK70F** Fixed foldable top bunk 700 x 1900mm
 - PH-CAB2** 1.8kW Air to air night heater
 - PH-ENGCA** Engine and cab night heater
 - PH-SS** Short stop heater
 - SLCP-BAS** Basic sleeper control panel - includes interior light, parking heater, roof hatch and door lock
 - SAFE** Safe box for driver's personal items
 - ETSB-F** Storage on engine tunnel - on front top
 - ETSB-FR** Storage on engine tunnel - on front top and at rear cab wall
 - ETSB-FRS** Storage on engine tunnel - on front top & at rear cab wall & storage recessed into tunnel on right hand side
 - ETSB-FS** Storage on engine tunnel - on front top and storage recessed into tunnel on right hand side
 - ETSB-R** Storage on engine tunnel - box at rear cab wall
 - ETSB-RS** Storage on engine tunnel - at rear cab wall and storage recessed into tunnel on right hand side
 - ETSB-S** Storage on engine tunnel - recessed into tunnel on right hand side
 - RUS-BAS** Rear cab upper storage 154 litres - 300 mm high
 - RUS-HIG** Rear cab upper storage 245 litres - 440 mm high
 - TABLE** Folding and height adjustable table - on lower bunk
 - REF-ICPK** Refrigerator preparation kit, engine tunnel mounted
 - REFR-FRS** 28 litre rear upper wall mounted refrigerator with dividers
 - BOTH-D** One bottle holder under dashboard centre section
 - COFMA-PK** Coffee maker, preparation kit.
 - INLI-BAS** Basic white interior lights
 - INLI-NL** Interior white and red night light with no dimmer
 - INLI-NLD** Interior white and red night light with dimmer function
 - ARL-FLEX** Two flexible reading lamps (snake lamps)
 - RH-EE** Without roof hatch
 - RH-ETR** Roof & escape hatch - Electrically operated, tinted glass with rear opening
 - RH-MSR** Steel roof hatch - Manually operated with rear opening
 - RH-MTR** Roof & escape hatch - Manually operated, tinted glass with rear opening
 - URH** Without roof hatch
 - SWIND-BS** Extra side window on both sides behind "B" pillar
 - SWIND-PS** Rear side window, passenger side
 - VANMIR** Vanity mirror in front shelf
 - AS-FUS** Extra shelf in front upper storage compartments
 - INFOT-PK** Preparation kit for the mounting of a flat screen TV in cab above the driver's door, includes bracket, electrical and speaker connections
- ### CAB EXTERIOR
- PAICS-B** Basic cab paint - mirrors, sunvisor, instep and bumper supplied in natural finish - grey
 - GLAS-TIN** Tinted windows.
 - AWIND-RF** Rear window
 - DGLAS-L** Laminated door glass
 - LOCK-MAN** Manual door locking
 - LOCK-MRP** Manual door locking with internal remote control (from driver side) of passenger door
 - LOCK-REM** Central locking with remote control
 - BUMP-HD** Heavy duty front bumper
 - GUARD-EH** Engine guard to protect sump and engine hoses
 - BUGNET** Insect screen in front of radiator
 - CTILT-P-E** Electrically operated hydraulic cab tilt
 - CTILT-P-M** Manually operated hydraulic cab tilt
- FCABS-A** Front cab - Air suspension
 - FCABS-M** Front cab - Mechanical spring suspension
 - RCABS-A** Rear cab suspension - Air
 - RCABS-M** Rear cab suspension - Mechanical spring
 - MIRCOMFX** Electrically heated and operated exterior mirrors with wide angle mirror on both sides and kerb view mirror on passenger side
 - MIRSTDX** Electrically heated exterior mirrors with wide angle mirror on both sides and kerb view mirror on passenger side
 - AMIR-F20** Auxiliary front view mirror with a 200mm radius
 - SUNV-H** External smoke grey sunvisor
 - AD-ROOF** Roof air deflector
 - AD-SIDEL** Side air deflector extension panels
 - AD-SIDES** Short cab side air deflector for rigid bodywork
 - HL-BAS2** Halogen H1 head lamps
 - HL-BASIC** Halogen H7 head lamps
 - HL-BHID2** Dynamic high intensity Bi-Xenon head lamps
These follow the steering movement and direction of the truck
 - HL-CLEAN** Head lamp cleaner - washer jets
 - HLP-ST** Headlamp protection
 - HL-ADJ** Adjustable headlights with switch in the cab
 - ASL-RF2** Two Hella H11 70W spotlamps in sign box - only available with the basic headlight and no lower driving lights.
 - ASL-RFPK** Preparation kit for two spotlamps in sign box
 - BEACOA2F** Two front roof mounted amber beacon rotating warning lamps
 - BEACOA2R** Two rear roof mounted (on accessory bracket) amber beacon flashing warning LED lamps
 - BEACON-P** Roof beacon wire preparation
 - BEACONA4** Four roof mounted (2 front/2 rear) amber beacon rotating warning lamps
 - CABPT-R1** Single outlet for roof mounted accessories
 - CABPT-R2** Twin outlets for roof mounted accessories.
 - SPOTP-F** Spotlamp preparation in front, max 280W
 - SPOTP-R** Spotlamp preparation on roof, max 280W
 - SPOTP-RF** Spotlamp preparation on cab roof and in cab front, max 2x280W
 - CSGN-FMX** "Volvo FMX" headboard logo
 - HORN-F1S** Single tone Jericho air horn chassis mounted
 - HORN-R2S** Two roof mounted air horns
 - ANT-CBR** Roof mounted antenna for CB radio, single aerial
 - ACCBP-AP** Front, middle & rear roof mounted accessory brackets
 - ACCBP-F** Front roof mounted accessory bracket
 - ACCBP-FM** Front & middle roof mounted accessory brackets
 - ACCBP-FR** Front & rear roof mounted accessory brackets
 - ACCBP-M** Middle roof mounted accessory bracket
 - ACCBP-R** Rear roof mounted accessory bracket
 - ACCBP-RM** Rear & middle roof mounted accessory brackets
 - REFS-TW** White cab conspicuity markings by packed in cab
 - REFS-TY** Yellow cab conspicuity markings by packed in cab

SUPERSTRUCTURE PREPARATIONS

- SRWL-PK** Wiring preparation for side & rear work/reverse lamps on side of chassis and a three-position switch, maximum 280W
- SWL-2FW** Two H3 70W white front chassis mounted (LH/RH side) working lamps and a 2-position switch (On/Off)
- SWL-2RW** Two H3 70W white rear chassis mounted (LH/RH side) working lamps and a 2-position switch (On/Off)
- SWL-4W** 4 H3 70W white front (2) & rear (2) chassis mtd (LH/RH side) working lamps & 2-pos switch (On/Off)
- SWL-PK** Wiring preparation for side work/reverse lamps on side of chassis and a three-position switch, maximum 280W
- WLC-H2A** Two H3/70W working lamps with amber coloured lens high mounted back of cab

■ Standard Equipment

□ Optional Equipment

For more detailed information about cab and powertrain equipment, please refer to separate specification sheets.

For all possible options and combinations of options please consult your Volvo sales contact who can create a specification to match your requirements using the Volvo Sales Support system (VSS).

The factory reserves the right to modify design and change equipment without previous notification. The specification can vary from country to country.

MODEL RANGE

FMX13 4x2 Platform - Rear Air Suspension FM 42 R3HAX

- **WLC-H2W** Two H3/70W white working lamps high mounted on the back of cab
- **WLC-PKCH** Preparation kit (cables and switch) for cab mounted chassis working lamp
- **WLC-PKH** Preparation kit, cables and switch for high mounted working lamps back of cab
- **WLC-PKL** Preparation kit, cables and switch for low mounted working lamps back of cab
- **WLC-PKLH** Preparation kit - cables and switch for low and high mounted working lamps back of cab.

- **ECBB-BAS** Body builder electrical centre without body builder module
- **ECBB-HIG** Body builder electrical centre with body builder module

- **BBCHAS1** One 7-pole connector for Body builder interface
- **BBCHAS3** Three 7-pole connectors for Body builder interface

- **BEPR-T2** Body builder electrical software preparation for tipper with remote control

- **EXSTER** External steering control, with VDS and bodybuilder module
- **TD-BAS** Trailer detection WITHOUT LED sensing
- **TD-LED** Trailer detection with LED sensing

- **FRFS-BS** Frame rail free space on both sides to give space for crane legs or other equipment.

- **FBA-BTF** Lower front body attachments for torsionally flexible - platform body
- **FBA-BTSF** Lower front body attachments for torsionally semi-flexible body - box or curtainsider

- **HBA-FSFB** Holes for body attachments - flexible/semi-flexible body
- **HBA-SB** Holes for body attachments - stiff body

- **RBA-T2** Lower rear body attachments for helper frame

- **CRANEPK1** Crane plates mounted to frame, for cranes up to 10 tonne metre capacity
- **CRANEPK2** Crane plates mounted to frame, for cranes up to 20 tonne metre capacity
- **CRANEPK4** Crane plates mounted to frame, for cranes up to 40 tonne metre capacity

- **AUXL-SPK** Electrical preparation kit - wiring and switch for snow plough lights

- **TAILPRE2** Tail lift preparation kit, wireless remote operation
- **TAILPREP** Taillift preparation kit - cab switch and warning in driver display

- **AESW2** Two Body builder bistable electrical switches (marked AUX1 / AUX2)
- **AESW2PK** 2 Body builder bistable el.switches (marked AUX1/AUX2) and prep. for 4 more switches

- **AUXSW-4** Wiring for 4 extra switches (from Body builder electrical centre to switch positions)

DELIVERY SERVICES

- **TGW-3GWL** Telematics gateway with GSM/GPRS/3G modem and wireless lan WLAN

- **FMS-PK** Fleet Management System gateway

- **DRUT** "My Truck App" Two years subscription to driver utility application

VOLVO

Volvo Truck Corporation
volvotrucks.com