

# MODEL RANGE

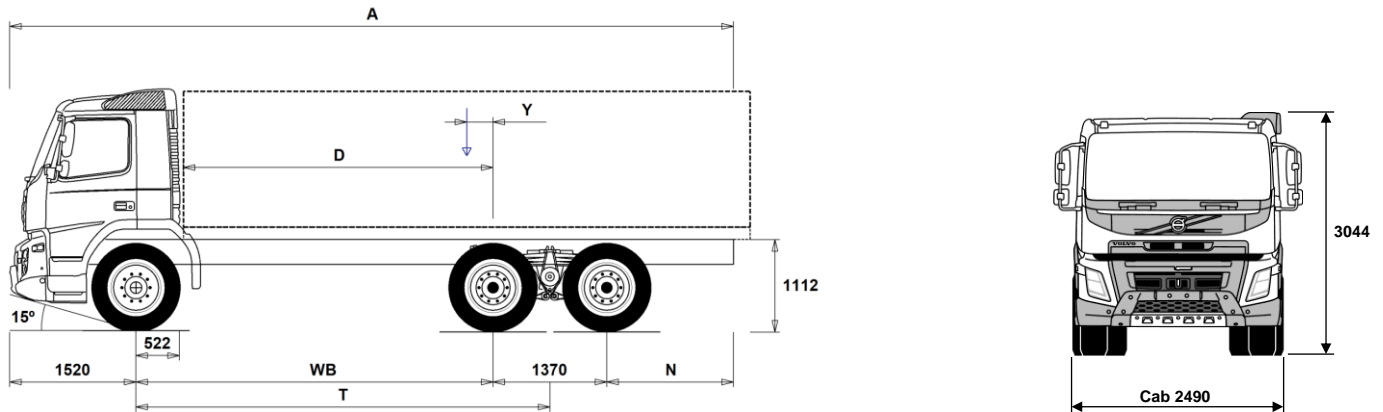

Volvo Trucks. Driving Progress

FMX11 6x4 Rigid - High B Ride - N3 Cranked front axle for on road work FM 64 R1HBX



## Chassis Dimensions [mm]

WB Wheelbase	3400	3700	3900	4300	4600	4900	5200	5600
A Overall Chassis Length	8165	8615	8915	9565	10015	10465	10965	11565
D Center of rear axle to front of body	2828	3128	3328	3728	4028	4328	4628	5028
N Rear Overhang (Min.)	1225	1225	1225	1225	1225	1225	1225	1225
N Rear Overhang (Max.)	1875	2025	2125	2375	2525	2675	2875	3075
T Theoretical Wheelbase	4085	4385	4585	4985	5285	5585	5885	6285
Y Center of Gravity for Payload (Min.)	-133	-95	-69	-19	19	55	94	141
Y Center of Gravity for Payload (Max.)	94	150	186	260	316	369	426	497

## Chassis Weights [kg]

Front Axle	4570	4580	4590	4610	4625	4645	4655	4675
Rear Bogie	3450	3470	3485	3530	3555	3595	3625	3665
Kerb Weight	8020	8050	8075	8140	8180	8240	8280	8340
Payload (including body, driver, fuel, etc.)	17980	17950	17925	17860	17820	17760	17720	17660

## Turning Diameter [mm]

Turning Circle Diameter Kerb to Kerb	14500	15500	16100	17300	18200	19100	20000	21300
Turning Circle Diameter Wall to Wall	16000	16900	17500	18800	19700	20600	21500	22800

## Plated Weights [kg]

	Plated	Design
Gross Vehicle Weight	26000	29000
Gross Combination Weight	44000	44000
Front Axle	8000	8000
Rear Bogie	19000	21000

## Important Notes

### Chassis Dimensions

Cab Height: +416 mm for CAB-HSLP.

Front Axle to Back of Cab: +424 mm for CAB-HSLP and CAB-SLP.

D-measure includes a front clearance of 50 mm and for rigid trucks also a subframe of 100 mm.

Height can vary  $\pm 20$  mm for leaf and  $\pm 10$  mm for air suspension.

All dimensions are for unladen chassis and any tag axles down. Chassis height used: CHH-HIGH.

Rear overhang used for vehicle weight calculation is the maximum rear overhang (N Max.) for selected wheelbase.

Weight and dimensions are based upon the following tyres:

Front Axle Tyres: 315/80R22.5

Drive Axle Tyres: 315/80R22.5

**Chassis weight includes oil, water, AdBlue, 0 litres fuel and without driver. Kerb weight can vary  $\pm 3\%$ .**

Turning diameters are theoretically calculated.

Legal weights can differ from country to country.

For more detailed weight information, including optional equipment weights, ask your Volvo sales contact to enter your specification into the Volvo Weight Information system (WIS).

Do NOT use this drawing for bodybuilding. Refer to Volvo Bodybuilder Instructions and chassis assembly drawing FM64R1HBX.

# MODEL RANGE

FMX11 6x4 Rigid - High B Ride - N3 Cranked front axle for on road work FM 64 R1HBX

## TRUCK USE

- **RC-ROUGH** Operating class on/off road
- **GARB-PRE** Garbage preparation
- **TIPP-PRE** Tipper vehicle preparation
- **UNIFORM** Basic platform vehicle

## CORE COMPONENTS

- **CHH-HIGH** Chassis height standard - For a specific loading height always check the unique BEP chassis drawing
- **RADD-BR** B-ride rear three spring bogie suspension
- **FMX-DAY** Day cab - with steel safety cage design  
Designed and built to Swedish impact and ECE R29 regulations
- **FMX-HSLP** Globetrotter cab - with steel safety cage design  
Designed and built to Swedish impact and ECE R29 regulations
- **FMX-SLP** Sleeper cab - with steel safety cage design  
Designed and built to Swedish impact and ECE R29 regulations
- **EU6SCR** Emission level - Euro 6
- **D11K330** D11K330 10.8l engine developing 330hp at 16-1900rpm.  
Peak torque 1600Nm at 950-1400rpm.
- **D11K380** D11K380 diesel engine, 380hp, 1800Nm SCR and EGR
- **D11K430** D11K430 diesel engine, 430hp, 2050Nm SCR and EGR
- **D11K460** D11K460 diesel engine, 460hp, 2200Nm SCR and EGR
- **EBR-EPG** Exhaust brake controlled by steering column switch
- **EBR-EPGC** Exhaust pressure governor for I shift gearbox
- **EBR-VEB** Volvo engine brake and exhaust pressure governor retardation 300kW
- **AT2612F** AT2612F 12-speed "I-shift" automated mechanical gearbox suitable for gross train weights up to 60tonne only refer to sales engineering when used in conjunction with a PTO
- **ATO2612F** ATO2612F 12-speed "I-shift" overdrive automated mechanical gearbox suitable for gross train weights up to 60tonne refer to sales engineering when used in conjunction with a PTO
- **PT2106** Powertronic automatic 6-speed gearbox, max. engine torque 2100 Nm, max. permitted GCW 100000 kg
- **RTH2610F** RTH2610F hub reduction tandem 26tonne drive axles, GCW 100 tonnes with differential and cross locks\*  
\* Cross locks replaced by a dog clutch if tandem axle lift is specified
- **RTS2370A** RTS2370A single reduction tandem 23tonne drive axles with differential and cross locks\* - design GCW 70tonnes.  
\* Cross locks replaced by a dog clutch if tandem axle lift is specified

## PACKAGES

- **DRIVEFM** Driving package
- **DRIVEFM+** Driving plus package
- **BEDFM** One bed resting package
- **AUDHIG** High Power Audio system: RDS radio with CD player - also playing MP3/WMA files from CD -, with integrated bluetooth phone and USB/Line inputs. FM/AM antenna, speakers in dashboard, doors, and sleeping compartment.
- **MEDIA** AM/FM Bluetooth radio without CD player.  
USB and Aux line inputs.  
Speakers in dashboard, doors, and sleeping compartment.  
7" touch screen with personal apps.
- **MEDIADF** AM/FM Bluetooth radio without CD player.  
USB and Aux line inputs.  
Speakers in dashboard, doors, and sleeping compartment.  
7" touch screen with personal and professional apps.  
Dynafleet vehicle on-board data display with office internet support.
- **MEDIANAV** AM/FM Bluetooth radio without CD player.  
USB and Aux line inputs.

■ Standard Equipment      □ Optional Equipment

For more detailed information about cab and powertrain equipment, please refer to separate specification sheets.

For all possible options and combinations of options please consult your Volvo sales contact who can create a specification to match your requirements using the Volvo Sales Support system (VSS).

The factory reserves the right to modify design and change equipment without previous notification.  
The specification can vary from country to country.

- **MEDIANDF** Speakers in dashboard, doors, and sleeping compartment.  
7" touch screen with personal and professional apps.  
Truck based satellite navigation (live updates not included)  
AM/FM Bluetooth radio without CD player.  
USB and Aux line inputs.  
Speakers in dashboard, doors, and sleeping compartment.  
7" touch screen with personal and professional apps.  
Truck based satellite navigation (live updates not included)  
Dynafleet vehicle on-board data display with office internet support.

- **RCHAPAC1** Chassis Package Rigid

## CHASSIS

- **FST-PAR** Front suspension type - 2 leaf parabolic springs
- **FST-PAR3** Front suspension type - 3 leaf parabolic springs
- **FAL10.0** Front axle design capacity 10 tonnes - Ensure that you have checked the tyre load index
- **FAL7.1** Front axle design capacity 7.1 tonnes
- **FAL7.5** Front axle design capacity 7.5 tonnes
- **FAL8.0** Front axle design capacity 8.0 tonnes - Ensure that you have checked the tyre load index
- **FAL8.5** Front axle design capacity 8.5 tonnes
- **FAL9.0** Front axle design capacity 9.0 tonnes - Ensure that you have checked the tyre load index
- **FSM-LUB** Lubricated rear shackles on front suspension pins and bushings
- **FSTAB** Front anti-roll bar
- **FSTAB2** Front anti-roll bar medium stiffness
- **FSTAB3** Front stiff anti-roll bar
- **RAL21** Rear bogie design capacity 21 tonnes
- **RSTAB1** Rear anti-roll bar
- **ACTST-TO** Volvo Dynamic Steering (VDS) with with extra electronic pump and torque overlay
- **ASFE-BAS** Active steering feature - Basic - Volvo Dynamic Steering only
- **ASFE-PS** Active steering feature - Volvo Dynamic Steering with personal settings
- **PSS-SING** Single power steering system
- **PSP-FIX** Power steering pump with fixed displacement
- **PSP-VAR** Power steering pump with variable displacement
- **EBS-MED** EBS medium package including "hill" hold function
- **RST-PAR1** Rear Suspension, Parabolic springs
- **ABS** Anti lock brakes
- **FBREG-E** Front regulating brake valve, EBS
- **FBREG-RP** Front regulating brake valve, reduced pressure/low pressure range
- **FRAME300** Frame rail section external height 300 mm
- **FST7070** Frame thickness - web and flange 7.0mm
- **FST8080** Frame thickness - web and flange 8.0mm
- **FIL-EEEE** Inner liner from end of engine to end of bogie
- **FIL-EEEE** Inner liner from end of engine to end of frame
- **FIL-FBEB** Inner liner over rear bogie
- **FIL-FBEF** Inner liner from front of bogie to end of frame
- **FIL-TXEB** Inner liner from gearbox member to end of bogie
- **FIL-TXEF** Inner liner from gearbox member to end of frame
- **BBOX-L** Battery box located on left hand side
- **2BAT210B** 2 x 210 Ah capacity Gel batteries
- **2BATT170** 2 x 170 Ah capacity batteries
- **2BATT225** 2 x 225 Ah capacity batteries
- **BATTAMP** Battery voltage and ampere gauge
- **BATTIND** Battery charge indication
- **ADR2** ADR package for transportation of dangerous goods on road (Note does NOT include safe loading pass package if required this is quoted separately)

# MODEL RANGE

## FMX11 6x4 Rigid - High B Ride - N3 Cranked front axle for on road work FM 64 R1HBX

- MSWI-A** Main switch - ADR switch circuit shut down
  - MSWI-C** Main switch - Chassis mounted toggle switch by battery box
  - MSWI-R** Main switch - Key fob operated remote controlled
  - R365A71** Right tank 365litre aluminium diameter 710mm  
Min volume 255l  
Max volume 885l
  - UL-FUEL** Without left fuel tank  
Min volume 160l  
Max volume 730l
  - ADTP-L** AdBlue tank on left hand side
  - ADTP-R** AdBlue tank on right hand side
  - ADB048** AdBlue tank usable volume 48 litres
  - ADB064** AdBlue tank usable volume 64 litres
  - ADB068** AdBlue tank usable volume 68 litres
  - ADB090** AdBlue tank usable volume 90 litres
  - FCAP-L** Locking fuel filler cap
  - FUFF-AS** Fuel filling anti-spillage device
  - FUFF-ATS** Fuel filling anti-theft and anti-spillage devices
  - ESH-LEFT** Horizontal silencer, left exhaust outlet
  - ESH-REAR** Horizontal silencer, rear exhaust outlet
  - ESH-RIGH** Horizontal silencer, right exhaust outlet
  - ESH-VERT** Horizontal silencer, vertical exhaust outlet
  - EXST-SSP** Stainless steel exhaust stack - NOT polished
  - EXST-ST** Steel exhaust stack
  - HS-NAR** Narrow heat shield
  - WHC-FIX2** Two fixed wheel chocks
  - WHC-FOL2** Two foldable wheel chocks
  - WHCP-F** Wheel chock(s) stored in the front part of the vehicle
  - WHCP-M** Wheel chock(s) stored in the middle part of the vehicle
  - WHCP-R** Wheel chock(s) stored in the rear part of the vehicle
  - WHCP-T** Transport mounted wheel chock(s) stored in cab outer luggage locker
  - TB-L80** Toolbox 800 mm, left side
  - TB-R80** Toolbox 800 mm, right side
  - SUP-BAS** EC approved chassis side guards
  - CHAIN-S** Snow chains
  - HOOK-SC** Snow chain hooks
  - TOWF-HD1** One heavy duty front towing device
  - TOWMBRH** Towing member, high mounted in centre of frame, D = 190
  - TOWMBRL1** Towing member, low mounted under the frame
  - TOWMBRM** Towing member, medium mounted in line with frame lower flange
  - RFEC-L** Rear frame end, lower flange cut for centre axle drawbar.
  - RFEC-S** Rear frame end, straight cut for regular platform applications
  - RFEC-U** Rear frame end, upper cut for tipper applications.
  - C-RI4040** Towing coupling, Ringfeder 4040 G-150
  - C-RI5055** Towing coupling, Ringfeder 5055 G-150
  - C-RO400G** Towing coupling, Rockinger 400 G-150 for 40mm eyes
  - C-RO50** Rockinger RO 50 50mm for centre axle trailer
  - TOWR-ONE** Towing hitch attached to rear crossmember
  - TREL-PK** Trailer electrical preparation kit - chassis/cab wiring
  - TREL14** Single 14 pole electrical trailer connector
  - TREL15** Single 15 pole electrical trailer connector - ADR certified
  - TREL7** 7 pole - 24N trailer electrical suzie
  - TREL7-7** 24N and 24S trailer electrical suzies
  - TBC-DUO** Duomatic type air line connectors
  - TBC-EC** Palm coupling type air line connectors
  - TRBR-HCF** Full pressure hand controlled trailer brake
  - TRBR-STA** Stationary trailer brake control
  - TRB-STRE** Stretch Brake - Automatic low speed trailer brake activation to avoid jack-knifing and improve steerability
  - RUP-FOLD** Folding EC approved aluminium rear underrun
  - RUP-FOSL** Folding & sliding EC approved aluminium rear underrun
  - RFEND-B** Three piece EC approved rear mud wings and spray flaps
  - RFEND-T** Rear mud wings, transport mounted
  - RFH-BAS** Basic rear wing height
  - RFH-HIG** High rear wing height - higher wing tops
  - RFH-LOW** Lower rear wing height - shallower wing tops
  - ATANK-AL** Aluminium air tanks
  - ATANK-ST** Steel air tanks
  - RESTS-W** White conspicuity markings on chassis - sideguards, toolbox and rear overhang
  - REST-RUP**
  - TL-LED** LED Tail lights
  - BLIGHT-E** Emergency brake light
- ### WHEELS & TYRES
- RT-AL** Alcoa brushed aluminium rims with standard holes for long stud fixing on all axles
  - RT-ALDP** Alcoa Dura-Bright EVO aluminium rims with standard holes long stud fixing on all axles, requires cleaning with a ph neutral solution - washing up liquid.
  - RT-ALDPD** Alcoa Dura-Bright EVO aluminium rims with countersunk holes for short stud fixing on all axles, requires cleaning with a ph neutral solution - washing up liquid.
  - RT-ALDU** Alcoa brushed aluminium rims with countersunk holes for short stud fixing on all axles
  - RT-SPOKE** Spoke rims on all axles
  - RT-STEEL** Steel rims on all axles
  - WCAP** Aerodynamic hub caps
  - BRREC001** Bridgestone ECOPIA H - Energy rating C
  - COREC001** Continental ECOPLUS HS3 XL/HD3 - Energy rating B or C depending on size
  - COREC002** Continental ECOPLUS HS3/HD3 - Energy rating B or C depending on size
  - COREC003** Continental Efficient Pro S/D - Fuel Tyre Recommendation 3 Reduced mileage compared to Conti EcoPlus long haul pattern please consider when selecting these tyres.
  - GYREC001** Good Year FUELMAX S/HL/D - Energy rating B or C depending on size
  - GYREC002** Good Year FUELMAX S/D - Energy rating B or C depending on size
  - GYREC003** Good Year FUELMAX S/(O)/D - Fuel tyre Recommendation 3
  - MIREC001** Michelin XFA2/X-LINE Energy - Fuel tyre Recommendation 1
  - MIREC002** Michelin XZA2/X-LINE Energy - Fuel tyre Recommendation 2
  - MIREC003** Michelin X-LINE Energy - Fuel tyre Recommendation 3
  - MIREC004** Michelin X Line Energy F/D2 - Energy rating A
  - SPWT-D** Spare wheel & tyre with rear tyre pattern
  - SPWT-F** Spare wheel & tyre with front tyre pattern
  - SWCP-LF** Spare wheel carrier on left side of chassis ahead of rear axle
  - SWCP-R** Rear mounted spare wheel carrier
  - SWCP-T** Spare wheel supplied temporarily strapped to chassis
  - SWCP-TP** Temporary spare wheel carrier on top of chassis frame
  - JACK-12T** 12 tonne bottle jack
  - JACK-15T** 15 tonne bottle jack
  - JACK-20T** 20 tonne bottle jack
  - TOOL-BAS** Basic Toolkit
  - TOOLKIT** Complete tool kit
  - INFLAHOS** Tyre inflation hose
  - GAUGE-TP** Tyre pressure gauge
  - OBDEP-C** Euro 6 Step C emission level
  - OBDEP-D** Euro 6 Step D emission level
- ### DRIVELINE EQUIPMENT
- TRAP-HD** Reinforced gearbox application

Standard Equipment       Optional Equipment

For more detailed information about cab and powertrain equipment, please refer to separate specification sheets.

For all possible options and combinations of options please consult your Volvo sales contact who can create a specification to match your requirements using the Volvo Sales Support system (VSS).

The factory reserves the right to modify design and change equipment without previous notification. The specification can vary from country to country.

# MODEL RANGE

## FMX11 6x4 Rigid - High B Ride - N3 Cranked front axle for on road work FM 64 R1HBX

<input type="checkbox"/> <b>TP-CON</b>	Construction Package	<input type="checkbox"/> <b>PTPT-F</b>	Powertronic PTO, 1 front/upper rear facing SAE flange conn. for prop shaft (max.850 Nm)
<input type="checkbox"/> <b>TP-DIST</b>	Distribution Package	<input type="checkbox"/> <b>PTR-D</b>	Gearbox PTO for plug-in pump, 0.71xeng speed
<input type="checkbox"/> <b>TP-HD</b>	I-shift software - Heavy duty for high GCW Special conditions apply consult Sales Engineering	<input type="checkbox"/> <b>PTR-DH</b>	Gearbox driven high speed PTO for one plug-in hydraulic pump
<input type="checkbox"/> <b>TP-LONG</b>	Long Haul Package	<input type="checkbox"/> <b>PTR-DM</b>	Gearbox driven medium speed PTO for one plug-in hydraulic pump
<input type="checkbox"/> <b>AMSO-AUT</b>	Enhanced I-shift software with manual shift available in auto mode and kickdown facility on accelerator pedal	<input type="checkbox"/> <b>PTR-F</b>	Gearbox driven PTO with rear flange connection
<input type="checkbox"/> <b>AVO-ENH</b>	Enhanced software for off road driveability and starting	<input type="checkbox"/> <b>PTR-FH</b>	Gearbox driven high speed PTO with SAE drive flange
<input type="checkbox"/> <b>APF-ENH</b>	I-shift enhanced PTO functions	<input type="checkbox"/> <b>PTR-FL</b>	Gearbox driven low speed PTO with SAE drive flange
<input checked="" type="checkbox"/> <b>CS43B-O</b>	Single plate 430mm (17") clutch	<input type="checkbox"/> <b>PTRD-D</b>	Gearbox driven HIGH SPEED PTO for two plug-in hydraulic pumps
<input type="checkbox"/> <b>RET-TH</b>	Gearbox mounted retarder	<input type="checkbox"/> <b>PTRD-D1</b>	PTRD-D1 Gearbox driven HIGH SPEED PTO (1 SAE flange & 1 plug-in hydraulic pump)
<input type="checkbox"/> <b>RET-TPT</b>	Hydraulic Retarder for Powertronic gearbox	<input type="checkbox"/> <b>PTRD-D2</b>	Gearbox driven HIGH SPEED PTO (2 SAE flanges & 1 plug-in hyd pump)
<input type="checkbox"/> <b>TC-HWO</b>	Automatic gearbox oil cooler - water to oil	<input type="checkbox"/> <b>PTRD-F</b>	PTO with 1 DIN + 1 flange connection rear, manual gearbox
<input type="checkbox"/> <b>TC-MAOH2</b>	Extra high performance transmission oil cooler - air to oil with front mounted radiator	<input type="checkbox"/> <b>HPG-F101</b>	Parker F1-101 gearbox mounted, fixed displacement, single flow, hydraulic pump
<input type="checkbox"/> <b>TC-MWO</b>	Basic transmission oil cooler - water to oil	<input type="checkbox"/> <b>HPG-F41</b>	Parker F1-41 gearbox mounted, fixed displacement, single flow, hydraulic pump
<input type="checkbox"/> <b>TC-MWOH2</b>	High performance transmission oil cooler - water to oil	<input type="checkbox"/> <b>HPG-F51</b>	Parker F1-51 gearbox mounted, fixed displacement, single flow, hydraulic pump
<input type="checkbox"/> <b>1COMP530</b>	Single cylinder, air compressor, 530 litres per minute	<input type="checkbox"/> <b>HPG-F61</b>	Parker F1-61 gearbox mounted, fixed displacement, single flow, hydraulic pump
<input type="checkbox"/> <b>2COM1100</b>	Two cylinder, air compressor, 1100 litres per minute	<input type="checkbox"/> <b>HPG-F81</b>	Parker F1-81 gearbox mounted, fixed displacement, single flow, hydraulic pump
<input checked="" type="checkbox"/> <b>2COMP900</b>	Two cylinder, air compressor, 900 litres per minute	<input type="checkbox"/> <b>EIDLESD</b>	Engine idle shut down
<input type="checkbox"/> <b>CLU-AIRC</b>	Clutchable air compressor	<input type="checkbox"/> <b>STWPOS-L</b>	LEFT HAND DRIVE
<input checked="" type="checkbox"/> <b>AIRIN-HI</b>	Roof mounted air intake behind cab on left hand side	<input checked="" type="checkbox"/> <b>STWPOS-R</b>	RIGHT HAND DRIVE
<input type="checkbox"/> <b>AIRIN-LO</b>	Low level air intake behind cab on left hand side	<input type="checkbox"/> <b>STWM-LE</b>	Leather steering wheel
<input type="checkbox"/> <b>ACL1ST-S</b>	Two stage air filter	<input type="checkbox"/> <b>STGW-AD2</b>	Adjustable steering wheel with neck tilt
<input checked="" type="checkbox"/> <b>24AL110B</b>	110 amp alternator	<input checked="" type="checkbox"/> <b>STGW-ADJ</b>	Adjustable steering wheel
<input type="checkbox"/> <b>24AL120B</b>	120 amp alternator	<input checked="" type="checkbox"/> <b>AIRBAG</b>	SRS Driver's air bag
<input type="checkbox"/> <b>24AL150B</b>	150 amp alternator	<input checked="" type="checkbox"/> <b>DRC-AMII</b>	DPF Regeneration control switch - for manual and switching off regeneration
<input checked="" type="checkbox"/> <b>CCV-C</b>	Closed crankcase engine ventilation	<input type="checkbox"/> <b>1DAYDIG</b>	Continental VDO DTCO 3.0 digital tachograph This tachograph can ONLY offer remote download if the option of Dynafleet or an FMS gateway has been specified with this order.
<input type="checkbox"/> <b>CCV-OX</b>	Closed crankcase ventilation for cold markets	<input checked="" type="checkbox"/> <b>1DAYDIG2</b>	Continental VDO DTCO 4.0 smart tachograph This tachograph can ONLY offer remote download if the option of Dynafleet or an FMS gateway has been specified with this order.
<input checked="" type="checkbox"/> <b>PRIM-EL</b>	Electrical priming pump	<input type="checkbox"/> <b>1DAYDIGP</b>	Continental VDO DTCO 3.0 digital tachograph For vehicles with long lead time - this includes prep kit for the retrofit of DTCO 4.0 tachograph. For updating to new legal demand for trick registration from 15th June 2019. This tachograph can ONLY offer remote download if the option of Dynafleet or an FMS gateway has been specified with this order.
<input type="checkbox"/> <b>PRIM-MAN</b>	Manual priming pump	<input type="checkbox"/> <b>ARSL</b>	Additional road speed limit - switch in dashboard
<input type="checkbox"/> <b>FUEQ-EH</b>	Fuel line electric heater	<input type="checkbox"/> <b>SPEED-DU</b>	Dual speed limiter
<input type="checkbox"/> <b>AF-R</b>	Hot fuel recirculation heated fuel filter	<input type="checkbox"/> <b>CRUIS-E</b>	Eco cruise control (with eco-roll and I-cruise, controls in steering wheel) Cruise control, standard
<input type="checkbox"/> <b>FUEFE2LW</b>	Large engine mounted dual fuel filter with water separator	<input checked="" type="checkbox"/> <b>CRUISEC</b>	Electronic Stability Control
<input checked="" type="checkbox"/> <b>FUEFE2SW</b>	Small engine mounted dual fuel filter with water separator	<input checked="" type="checkbox"/> <b>ESP-BAS1</b>	Electronic Stability Control
<input type="checkbox"/> <b>EST-AID</b>	Air inlet manifold starting heater element	<input type="checkbox"/> <b>ESPC-RO</b>	ESP (Electronic Stability Program) functionality control - Reduced / Off
<input type="checkbox"/> <b>220EBH15</b>	220V/1.5Kw electric engine block heater	<input type="checkbox"/> <b>HWSS-ACB</b>	Adaptive cruise control with forward collision warning and advanced emergency braking
<input type="checkbox"/> <b>PTER-100</b>	Rear engine mounted power-take-off with DIN 100 / ISO 7646 flange	<input checked="" type="checkbox"/> <b>HWSS-FCB</b>	Forward collision warning with basic cruise control and advanced emergency brake
<input type="checkbox"/> <b>PTER-DIN</b>	Rear engine mounted PTO with DIN5462 (female) splined shaft for a close coupled pump. Models with 3 steering axles will use this to drive the steering pump (AUXPSP)		
<input type="checkbox"/> <b>PTER1400</b>	Rear engine mounted power-take-off with SAE 1410 flange		
<input type="checkbox"/> <b>HPE-F101</b>	Parker F1-101, engine mounted, fixed displacement, single flow, engine mounted hydraulic pump		
<input type="checkbox"/> <b>HPE-F41</b>	Parker F1-41, engine mounted, fixed displacement, single flow, engine mounted hydraulic pump		
<input type="checkbox"/> <b>HPE-F51</b>	Parker F1-51, engine mounted, fixed displacement, single flow, engine mounted hydraulic pump		
<input type="checkbox"/> <b>HPE-F61</b>	Parker F1-61, engine mounted, fixed displacement, single flow, engine mounted hydraulic pump		
<input type="checkbox"/> <b>HPE-F81</b>	Parker F1-81, engine mounted, fixed displacement, single flow, engine mounted hydraulic pump		
<input type="checkbox"/> <b>HPE-T53</b>	Parker F2-53/53, engine mounted, Fixed displacement, Twin flow engine mounted hydraulic pump		
<input type="checkbox"/> <b>HPE-T70</b>	Parker F2-70/35, engine mounted, Fixed displacement, Twin flow engine mounted hydraulic pump		
<input type="checkbox"/> <b>HPE-V45</b>	Parker VP1-45, variable displacement, single flow, engine mounted hydraulic pump		
<input type="checkbox"/> <b>HPE-V75</b>	Parker VP1-75, variable displacement, single flow, engine mounted hydraulic pump		
<input type="checkbox"/> <b>PTPT-D</b>	Powertronic PTO, 1 front/upper DIN connection for plug-in		
<input checked="" type="checkbox"/> <b>Standard Equipment</b>		<input type="checkbox"/> <b>Optional Equipment</b>	

For more detailed information about cab and powertrain equipment, please refer to separate specification sheets.

For all possible options and combinations of options please consult your Volvo sales contact who can create a specification to match your requirements using the Volvo Sales Support system (VSS).

The factory reserves the right to modify design and change equipment without previous notification. The specification can vary from country to country.

# MODEL RANGE

FMX11 6x4 Rigid - High B Ride - N3 Cranked front axle for on road work FM 64 R1HBX

- |  |  |
|--|--|
| <ul style="list-style-type: none"> <li>■ <b>LSS-DW</b> Lane departure warning system</li> <li>□ <b>LCS</b> Lane change support</li> <li>□ <b>DAS-W</b> Driver Alert Support system</li> <li>□ <b>RSENS-W</b> Rain sensing windscreen wipers</li> <li>□ <b>CU-ECC</b> Electrically controlled air conditioning with sun sensor</li> <li>□ <b>CU-ECC2</b> Electrically controlled air conditioning with sun sensor, mist sensor, air quality sensor and carbon filter</li> <li>■ <b>CU-MCC</b> Climate unit with manual controlled air conditioning</li> <li>■ <b>IMMOBIL</b> Thatcham H2 approved immobiliser</li> <li>□ <b>ALARM-B</b> Thatcham H1 approved vehicle alarm - Cab only</li> <li>□ <b>ALARM-E</b> Enhanced vehicle alarm - Thatcham H1 approved - Cab plus external sensor for body/trailer</li> <li>□ <b>ALCOLOCK</b> Alcolock</li> <li>□ <b>PHONE-PK</b> Telephone preparation kit (antenna, antenna attachm. cable incl.)</li> <li>□ <b>WLIFT-AD</b> Electrical window lift, automatic up/down driver side</li> <li>■ <b>WLIFT-EB</b> Electrical window lift</li> <li>■ <b>WLIFT-ME</b> Mechanical window lift</li> <li>□ <b>ISUNS-BS</b> Side interior sun visor on both sides</li> <li>■ <b>ISUNS-DS</b> Driver's side interior sun visor</li> <li>■ <b>ISUNF-B</b> Interior front sun visor without mirror</li> <li>□ <b>ISUNF-MD</b> Interior front sun visor with mirror on driver side</li> <li>□ <b>ISUNF-RE</b> Electrically operated textile interior sun blind</li> <li>□ <b>ISUNF-RM</b> Manually operated textile interior sun blind</li> <li>□ <b>ADFS</b> Two extra DIN slots in front shelf - can be fitted with card or drawer available as an accessory</li> <li>■ <b>BUPALARM</b> Reverse alarm</li> <li>□ <b>BUPMON</b> Back up monitor with built in 7" screen on dash and one colour camera supplied loose for fitment by bodybuilder.</li> <li>□ <b>RTOLL-PK</b> Road toll PREPARATION kit for trucks operating with "Toll Collect" in Germany</li> <li>□ <b>REMC-MF</b> Multi-functio wireless remote control</li> <li>□ <b>FIREXT3S</b> 3kg fire extinguisher mounted on seat base</li> <li>□ <b>WARNVEST</b> High visibility warning vest - no sleeves</li> <li>□ <b>AIDKIT</b> First aid kit</li> <li>□ <b>AIDKIT1B</b> First aid kit</li> <li>□ <b>WARNLAMP</b> Portable warning lamp</li> <li>□ <b>LAMP-IN</b> Inspection lamp</li> <li>□ <b>BULBKIT</b> Bulb and fuse kit</li> <li>□ <b>WRITEPAD</b> Writing pad</li> <li>□ <b>UPHTRI10</b> Seats: Black embossed textile insert with light grey sides, black vinyl side bolster with blue vinyl side insert.<br/>Interior trim: Raven black bunk and curtains &amp; blue textile side walls</li> <li>■ <b>UPHTRI11</b> Seats: Light grey embossed textile insert, black raven metallic vinyl bolster with red vinyl side insert.<br/>Interior trim: Raven black bunk and curtains &amp; grey vinyl side walls</li> <li>□ <b>UPHTRI12</b> Seats: Blue soft textile insert, black vinyl bolster.<br/>Interior trim: Raven black bunk and curtains &amp; blue textile side walls</li> <li>□ <b>UPHTRI13</b> Seats: Dark grey leather insert and black leather bolster.<br/>Interior trim: Raven black bunk and curtains &amp; grey vinyl side walls</li> <li>□ <b>UPHTRI14</b> Seat: Dark grey leather insert and black leather bolster.<br/>Interior trim: Raven black bunk and curtains &amp; blue textile side walls</li> <li>■ <b>DST-CF4</b> Driver seat, comfort, suspended, belt in seat</li> <li>□ <b>DST-CF5</b> Driver seat, comfort, suspended, belt in seat, electrically heated</li> </ul> | <ul style="list-style-type: none"> <li>□ <b>DST-CF6</b> Driver seat, comfort, suspended, belt in seat, electrically heated, ventilated</li> <li>□ <b>SBD-RED</b> Red seat belts</li> <li>□ <b>SBPRE-DS</b> Driver seat belt pretensioner</li> <li>■ <b>PST-BAS1</b> Passenger seat - Fixed non suspended fold up with seatbelt mounted in cab</li> <li>□ <b>PST-BENC</b> Bench passenger seat</li> <li>□ <b>PST-CF4</b> Passenger seat - Comfort suspended with seatbelt mounted in seat</li> <li>□ <b>PST-CF5</b> Passenger seat - Comfort suspended &amp; heated with seatbelt mounted in seat</li> <li>□ <b>PST-STD2</b> Passenger seat - Fixed non suspended with seatbelt mounted in cab</li> <li>□ <b>PST-STD4</b> Passenger seat - Standard suspended with seatbelt mounted in cab</li> <li>□ <b>SBPRE-PS</b> Passenger seat belt pretensioner</li> <li>□ <b>ARM-DBPS</b> Two armrests on driver seat and one (outer) on passenger seat</li> <li>□ <b>ARMRE-BB</b> Two armrests on both driver and passenger seat.</li> <li>□ <b>ARMRE-DB</b> Two armrests, on driver seat only</li> <li>□ <b>ARMRE-PB</b> Two armrests, on passenger seat only</li> <li>□ <b>ARMRE-PS</b> Single armrest (next to driver) on passenger seat</li> <li>□ <b>ARU-BAS</b> Vinyl upholstered armrest</li> <li>□ <b>ARU-LEA</b> Leather upholstered armrest</li> <li>■ <b>FMAT-RU2</b> Rubber floor mats, extended</li> <li>□ <b>FMAT-RUB</b> Rubber floor mats</li> <li>□ <b>FMAT-T2E</b></li> <li>□ <b>FMAT-TX2</b> Textile and rubber floor mats</li> <li>□ <b>LBK-RES</b> Foldable rest bunk</li> <li>□ <b>LBK70</b> Lower bunk 700 x2000 mm, fixed</li> <li>■ <b>ULBK</b> Without lower bunk</li> <li>□ <b>MATL-FI</b> Firm lower bunk pocket sprung mattress</li> <li>□ <b>MATL-SF</b> Lower flexizone mattress - semi-firm, pocket springs up to 100kg - 16 stone</li> <li>□ <b>MATL-SO</b> Lower flexizone mattress - soft, pocket springs up to 85kg - 13.5 stone</li> <li>□ <b>OLMAT-BA</b> 35mm mattress overlay protector</li> <li>□ <b>OLMAT-PR</b> 50mm premium mattress overlay protector</li> <li>□ <b>TBK60F</b> Fixed foldable top bunk 600 x 1900mm</li> <li>□ <b>TBK70F</b> Fixed foldable top bunk 700 x 1900mm</li> <li>□ <b>PH-CAB2</b> 1.8kW Air to air night heater</li> <li>□ <b>PH-ENGCA</b> Engine and cab night heater</li> <li>□ <b>PH-SS</b> Short stop heater</li> <li>□ <b>SLCP-BAS</b> Basic sleeper control panel - includes interior light, parking heater, roof hatch and door lock</li> <li>□ <b>SAFE</b> Safe box for driver's personal items</li> <li>□ <b>ETSB-F</b> Storage on engine tunnel - on front top</li> <li>□ <b>ETSB-FR</b> Storage on engine tunnel - on front top and at rear cab wall</li> <li>□ <b>ETSB-FRS</b> Storage on engine tunnel - on front top &amp; at rear cab wall &amp; storage recessed into tunnel on right hand side</li> <li>□ <b>ETSB-FS</b> Storage on engine tunnel - on front top and storage recessed into tunnel on right hand side</li> <li>□ <b>ETSB-R</b> Storage on engine tunnel - box at rear cab wall</li> <li>□ <b>ETSB-RS</b> Storage on engine tunnel - at rear cab wall and storage recessed into tunnel on right hand side</li> <li>□ <b>ETSB-S</b> Storage on engine tunnel - recessed into tunnel on right hand side</li> <li>□ <b>RUS-BAS</b> Rear cab upper storage 154 litres - 300 mm high</li> <li>□ <b>RUS-HIG</b> Rear cab upper storage 245 litres - 440 mm high</li> <li>□ <b>TABLE</b> Folding and height adjustable table - on lower bunk</li> <li>□ <b>REF-ICPK</b> Refrigerator preparation kit, engine tunnel mounted</li> <li>□ <b>REFR-RUS</b> 28 litre rear upper wall mounted refrigerator with dividers</li> <li>□ <b>BOTH-D</b> One bottle holder under dashboard centre section</li> <li>□ <b>COFMA-PK</b> Coffee maker, preparation kit.</li> </ul> |
|--|--|

■ Standard Equipment

□ Optional Equipment

For more detailed information about cab and powertrain equipment, please refer to separate specification sheets.

For all possible options and combinations of options please consult your Volvo sales contact who can create a specification to match your requirements using the Volvo Sales Support system (VSS).

The factory reserves the right to modify design and change equipment without previous notification. The specification can vary from country to country.

# MODEL RANGE

FMX11 6x4 Rigid - High B Ride - N3 Cranked front axle for on road work FM 64 R1HBX

- **INLI-BAS** Basic white interior lights
- **INLI-NL** Interior white and red night light with no dimmer
- **INLI-NLD** Interior white and red night light with dimmer function
- **ARL-FLEX** Two flexible reading lamps (snake lamps)
- **RH-EE** Without roof hatch
- **RH-ETR** Roof & escape hatch - Electrically operated, tinted glass with rear opening
- **RH-MSR** Steel roof hatch - Manually operated with rear opening
- **RH-MTR** Roof & escape hatch - Manually operated, tinted glass with rear opening
- **URH** Without roof hatch
- **SWIND-BS** Extra side window on both sides behind "B" pillar
- **SWIND-PS** Rear side window, passenger side
- **VANMIR** Vanity mirror in front shelf
- **AS-FUS** Extra shelf in front upper storage compartments
- **INFOT-PK** Preparation kit for the mounting of a flat screen TV in cab above the driver's door, includes bracket, electrical and speaker connections

## CAB EXTERIOR

- **PAICS-B** Basic cab paint - mirrors, sunvisor, instep and bumper supplied in natural finish - grey
- **GLAS-TIN** Tinted windows.
- **AWIND-RF** Rear window
- **DGLAS-L** Laminated door glass
- **LOCK-MAN** Manual door locking
- **LOCK-MRP** Manual door locking with internal remote control (from driver side) of passenger door
- **LOCK-REM** Central locking with remote control
- **BUMP-HD** Heavy duty front bumper
- **GUARD-EH** Engine guard to protect sump and engine hoses
- **BUGNET** Insect screen in front of radiator
- **CTILT-P-E** Electrically operated hydraulic cab tilt
- **CTILT-P-M** Manually operated hydraulic cab tilt
- **FCABS-A** Front cab - Air suspension
- **FCABS-M** Front cab - Mechanical spring suspension
- **RCABS-A** Rear cab suspension - Air
- **RCABS-M** Rear cab suspension - Mechanical spring
- **MIRCOMFX** Electrically heated and operated exterior mirrors with wide angle mirror on both sides and kerb view mirror on passenger side
- **MIRSTDX** Electrically heated exterior mirrors with wide angle mirror on both sides and kerb view mirror on passenger side
- **AMIR-F20** Auxiliary front view mirror with a 200mm radius
- **SUNV-H** External smoke grey sunvisor
- **AD-ROOF** Roof air deflector
- **AD-SIDEL** Side air deflector extension panels
- **AD-SIDES** Short cab side air deflector for rigid bodywork
- **HL-BAS2** Halogen H1 head lamps
- **HL-BASIC** Halogen H7 head lamps
- **HL-CLEAN** Head lamp cleaner - washer jets
- **HLP-ST** Headlamp protection
- **HL-ADJ** Adjustable headlights with switch in the cab
- **UDRIVL** Without auxiliary driving lights
- **ASL-RF2** Two Hella H11 70W spotlamps in sign box - only available with the basic headlight and no lower driving lights.
- **ASL-RFPK** Preparation kit for two spotlamps in sign box
- **BEACOA2F** Two front roof mounted amber beacon rotating warning lamps

- **BEACOA2R** Two rear roof mounted (on accessory bracket) amber beacon flashing warning LED lamps
- **BEACON-P** Roof beacon wire preparation
- **BEACONA4** Four roof mounted (2 front/2 rear) amber beacon rotating warning lamps
- **CABPT-R1** Single outlet for roof mounted accessories
- **CABPT-R2** Twin outlets for roof mounted accessories.
- **SPOTP-F** Spotlamp preparation in front, max 280W
- **SPOTP-R** Spotlamp preparation on roof, max 280W
- **SPOTP-RF** Spotlamp preparation on cab roof and in cab front, max 2x280W
- **CSGN-FMX** "Volvo FMX" headboard logo
- **HORN-F1S** Single tone Jericho air horn chassis mounted
- **HORN-R2S** Two roof mounted air horns
- **ANT-CBR** Roof mounted antenna for CB radio, single aerial
- **ACCBP-AP** Front, middle & rear roof mounted accessory brackets
- **ACCBP-F** Front roof mounted accessory bracket
- **ACCBP-FM** Front & middle roof mounted accessory brackets
- **ACCBP-FR** Front & rear roof mounted accessory brackets
- **ACCBP-M** Middle roof mounted accessory bracket
- **ACCBP-R** Rear roof mounted accessory bracket
- **ACCBP-RM** Rear & middle roof mounted accessory brackets
- **REFS-CW** White cab conspicuity markings mounted on cab side
- **REFS-TW** White cab conspicuity markings by packed in cab
- **REFS-TY** Yellow cab conspicuity markings by packed in cab

## SUPERSTRUCTURE PREPARATIONS

- **BP-MI02**
- **BP-TI03**
- **CROSSRE** Cross reinforcement for swapbody
- **SRWL-PK** Wiring preparation for side & rear work/reverse lamps on side of chassis and a three-position switch, maximum 280W
- **SWL-2FW** Two H3 70W white front chassis mounted (LH/RH side) working lamps and a 2-position switch (On/Off)
- **SWL-2RW** Two H3 70W white rear chassis mounted (LH/RH side) working lamps and a 2-position switch (On/Off)
- **SWL-4W** 4 H3 70W white front (2) & rear (2) chassis mtd (LH/RH side) working lamps & 2-pos switch (On/Off)
- **SWL-PK** Wiring preparation for side work/reverse lamps on side of chassis and a three-position switch, maximum 280W
- **WLC-H2A** Two H3/70W working lamps with amber coloured lens high mounted back of cab
- **WLC-H2W** Two H3/70W white working lamps high mounted on the back of cab
- **WLC-PKCH** Preparation kit (cables and switch) for cab mounted chassis working lamp
- **WLC-PKH** Preparation kit, cables and switch for high mounted working lamps back of cab
- **WLC-PKL** Preparation kit, cables and switch for low mounted working lamps back of cab
- **WLC-PKLH** Preparation kit - cables and switch for low and high mounted working lamps back of cab.
- **ECBB-BAS** Body builder electrical centre without body builder module
- **ECBB-HIG** Body builder electrical centre with body builder module
- **BBCHAS1** One 7-pole connector for Body builder interface
- **BBCHAS3** Three 7-pole connectors for Body builder interface
- **BEPR-T2** Body builder electrical software preparation for tipper with remote control
- **EXSTER** External steering control, with VDS and bodybuilder module
- **TD-BAS** Trailer detection WITHOUT LED sensing
- **TD-LED** Trailer detection with LED sensing
- **FRFS-BS** Frame rail free space on both sides to give space for crane legs or other equipment.
- **FBA-BTF** Lower front body attachments for torsionally flexible - platform body

■ Standard Equipment                      □ Optional Equipment

For more detailed information about cab and powertrain equipment, please refer to separate specification sheets.

For all possible options and combinations of options please consult your Volvo sales contact who can create a specification to match your requirements using the Volvo Sales Support system (VSS).

The factory reserves the right to modify design and change equipment without previous notification. The specification can vary from country to country.

# MODEL RANGE

FMX11 6x4 Rigid - High B Ride - N3 Cranked front axle for on road work FM 64 R1HBX

---

- **FBA-BTSF** Lower front body attachments for torsionally semi-flexible body - box or curtainsider
- **HBA-FSFB** Holes for body attachments - flexible/semi-flexible body
- **HBA-SB** Holes for body attachments - stiff body
- **RBA-T2** Lower rear body attachments for helper frame
- **CRANEPK1** Crane plates mounted to frame, for cranes up to 10 tonne metre capacity
- **CRANEPK2** Crane plates mounted to frame, for cranes up to 20 tonne metre capacity
- **CRANEPK4** Crane plates mounted to frame, for cranes up to 40 tonne metre capacity
- **AUXL-SPK** Electrical preparation kit - wiring and switch for snow plough lights
- **TAILPRE2** Tail lift preparation kit, wireless remote operation
- **TAILPREP** Taillift preparation kit - cab switch and warning in driver display
- **AESW2** Two Body builder bistable electrical switches (marked AUX1 / AUX2)
- **AESW2PK** 2 Body builder bistable el.switches (marked AUX1/AUX2) and prep. for 4 more switches
- **AUXSW-4** Wiring for 4 extra switches (from Body builder electrical centre to switch positions)

## DELIVERY SERVICES

- **TGW-3GWL** Telematics gateway with GSM/GPRS/3G modem and wireless lan WLAN
- **FMS-PK** Fleet Management System gateway
- **DRUT** "My Truck App" Two years subscription to driver utility application

**VOLVO**

Volvo Truck Corporation  
volvotrucks.com