

MODEL RANGE

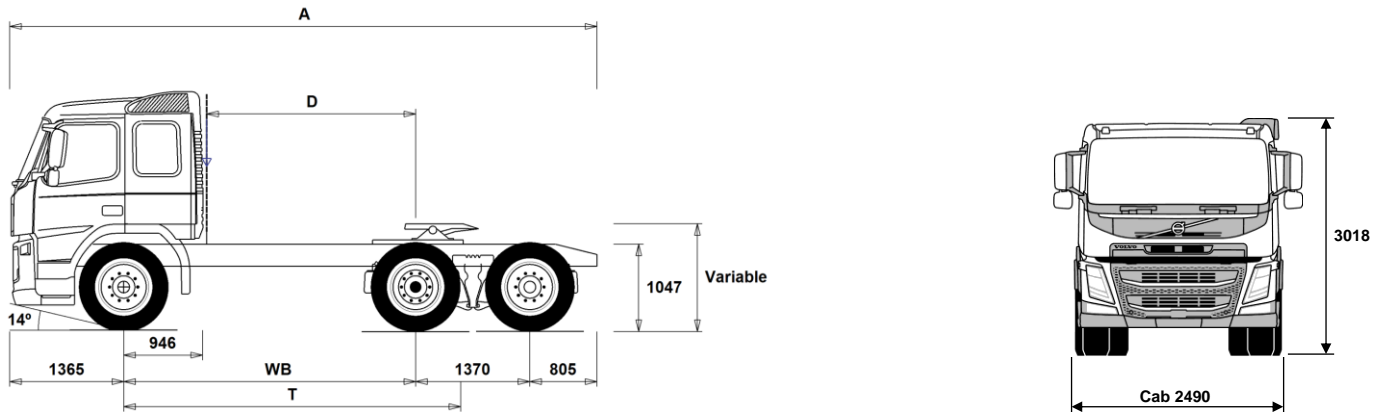

Volvo Trucks. Driving Progress

FM 13 6x2 Tractor - Tag - Rear Air Suspension FM 62 TT3HA



Chassis Dimensions [mm]

WB Wheelbase	3000	3200	3400	3900
A Overall Chassis Length	6540	6740	6940	7440
D Center of rear axle to back of cab	2004	2204	2404	2904
T Theoretical Wheelbase	3541	3741	3941	4441

Chassis Weights [kg]

Front Axle	4550	4565	4590	4625
Rear Bogie	3125	3120	3120	3120
Kerb Weight	7675	7685	7710	7745

Turning Diameter [mm]

Turning Circle Diameter Kerb to Kerb	12900	13500	14100	15600
Turning Circle Diameter Wall to Wall	14300	14900	15500	17100

Plated Weights [kg]

	Plated	Design
Gross Vehicle Weight	26000	26100
Gross Combination Weight	44000	44000
Front Axle	7100	7100
Rear Bogie	19000	19000

Important Notes

Chassis Dimensions

Cab Height: +416 mm for CAB-HSLP, -169 mm for CAB-LSLP, +554 mm for CAB-XHSL.

Front Axle to Back of Cab: -424 mm for CAB-DAY, -6 mm for CAB-LSLP.

D-measure includes a front clearance of 50 mm and for rigid trucks also a subframe of 100 mm.

Height can vary ± 20 mm for leaf and ± 10 mm for air suspension.

All dimensions are for unladen chassis and any tag axles down. Chassis height used: CHH-HIGH.

Height change when chassis height CHH-MED,FRAME266: 0 mm.

Weight and dimensions are based upon the following tyres:

Front Axle Tyres:	315/80R22.5
Drive Axle Tyres:	315/80R22.5
Trailing/Pusher Axle Tyres:	315/80R22.5

Chassis weight includes oil, water, AdBlue, 0 litres fuel and without driver. Kerb weight can vary $\pm 3\%$.

Turning diameters are theoretically calculated. Tag axle used: TA-FIXED.

Legal weights can differ from country to country.

For more detailed weight information, including optional equipment weights, ask your Volvo sales contact to enter your specification into the Volvo Weight Information system (WIS).

Do NOT use this drawing for bodybuilding. Refer to Volvo Bodybuilder Instructions and chassis assembly drawing FM62TT3HA.

MODEL RANGE

FM 13 6x2 Tractor - Tag - Rear Air Suspension FM 62 TT3HA

TRUCK USE

- RC-ROUGH** Operating class on/off road
- RC-SMOOT** Operating class highway

CORE COMPONENTS

- CHH-HIGH** Chassis height standard - For a specific loading height always check the unique BEP chassis drawing
- CHH-MED** Chassis height medium - For a specific loading height always check the unique BEP chassis drawing
- TAG-FIXD** Fixed tag axle twin tyres (4 tyres on complete axle)
- TAG-FIXS** Fixed tag axle single tyres (2 tyres on complete axle)
- RADT-GR** Rear air suspension, 2 axles - 1 driven/1 tag
- FM-DAY** Day cab - with steel safety cage design
Designed and built to Swedish impact and ECE R29 regulations
- FM-HSLP** Globetrotter cab - with steel safety cage design
Designed and built to Swedish impact and ECE R29 regulations
- FM-LSLP** Low sleeper cab - with steel safety cage design
Designed and built to Swedish impact and ECE R29 regulations
- FM-SLP** Sleeper cab - with steel safety cage design
Designed and built to Swedish impact and ECE R29 regulations
- FM-XHSL** Globetrotter LXL cab - with steel safety cage design
Designed and built to Swedish impact and ECE R29 regulations
- EU6SCR** Emission level - Euro 6
- D13K420** D13K420 12.8l engine developing 420hp at 14-1800rpm.
Peak torque 2100Nm at 860 -1400rpm.
- D13K460** D13K460 12.8l engine developing 460hp at 14-1800rpm.
Peak torque 2300Nm at 900-1400rpm.
- D13K500** D13K500 12.8l engine developing 500hp at 14-1800rpm.
Peak torque 2500Nm at 1000-1400rpm.
- EBR-EPG** Exhaust brake controlled by steering column switch
- EBR-EPGC** Exhaust pressure governor for I shift gearbox
- EBR-VEB+** Volvo engine brake + and exhaust pressure governor,
enhanced performance from additional exhaust rocker control.
Retardation 375kW
- AT2412F** AT2412F 12-speed "I-shift" automated mechanical gearbox
suitable for gross train weights up to 44tonne only
refer to sales engineering when used in conjunction with a PTO
- AT2612F** AT2612F 12-speed "I-shift" automated mechanical gearbox
suitable for gross train weights up to 60tonne only
refer to sales engineering when used in conjunction with a PTO
- ATO2612F** ATO2612F 12-speed "I-shift" overdrive automated mechanical
gearbox
suitable for gross train weights up to 60tonne
refer to sales engineering when used in conjunction with a PTO
- PT2606** Powertronic automatic 6-speed gearbox, max. engine torque
2600 Nm, max. permitted GCW 130000 kg
- SPO2812** SPO2812 - 12 speed I-shift Dual Clutch automated mechanical
gearbox GCW 60tonne
- RSH1370F** RSH1370F hub reduction rear axle with differential lock -
design GCW 70 tonne
- RSS1356** RSS1356 single reduction rear axle with differential lock -
design GCW 56 tonne
- RSS1360** RSS1360 single reduction rear axle with differential lock -
design GCW 60 tonne

PACKAGES

- LHFP-VE** Long Haul Fuel Economy driving package
- LHFP-VE+** NEW Long Haul Fuel+ product package
- AIRFLPAC** Air flow package including roof and side air deflectors plus
chassis skirts
- DRIVEFM** Driving package

Standard Equipment

Optional Equipment

For more detailed information about cab and powertrain equipment, please refer to separate specification sheets.

For all possible options and combinations of options please consult your Volvo sales contact who can create a specification to match your requirements using the Volvo Sales Support system (VSS).

The factory reserves the right to modify design and change equipment without previous notification.
The specification can vary from country to country.

- DRIVEFM+** Driving plus package
- BEDFM** One bed resting package
- AUDHIG** High Power Audio system: RDS radio with CD player - also
playing MP3/WMA files from CD -, with integrated bluetooth
phone and USB/Line inputs. FM/AM antenna, speakers in
dashboard, doors, and sleeping compartment.
- MEDIA** AM/FM Bluetooth radio without CD player.
USB and Aux line inputs.
Speakers in dashboard, doors, and sleeping compartment.
7" touch screen with personal apps.
- MEDIADF** AM/FM Bluetooth radio without CD player.
USB and Aux line inputs.
Speakers in dashboard, doors, and sleeping compartment.
7" touch screen with personal and professional apps.
Dynafleet vehicle on-board data display with office internet
support.
- MEDIANAV** AM/FM Bluetooth radio without CD player.
USB and Aux line inputs.
Speakers in dashboard, doors, and sleeping compartment.
7" touch screen with personal and professional apps.
Truck based satellite navigation (live updates not included)
- MEDIANDF** AM/FM Bluetooth radio without CD player.
USB and Aux line inputs.
Speakers in dashboard, doors, and sleeping compartment.
7" touch screen with personal and professional apps.
Truck based satellite navigation (live updates not included)
Dynafleet vehicle on-board data display with office internet
support.
- VISI15** Visibility package
- VISI15+** Visibility plus package
- ASAF15** New Active safety package
- ### CHASSIS
- FST-AIR** Front suspension type - air
- FST-PAR** Front suspension type - 2 leaf parabolic springs
- FST-PAR3** Front suspension type - 3 leaf parabolic springs
- FAL10.0** Front axle design capacity 10 tonnes - Ensure that you have
checked the tyre load index
- FAL7.1** Front axle design capacity 7.1 tonnes
- FAL7.5** Front axle design capacity 7.5 tonnes
- FAL8.0** Front axle design capacity 8.0 tonnes - Ensure that you have
checked the tyre load index
- FAL8.5** Front axle design capacity 8.5 tonnes
- FAL9.0** Front axle design capacity 9.0 tonnes - Ensure that you have
checked the tyre load index
- FSTAB** Front anti-roll bar
- FSTAB2** Front anti-roll bar medium stiffness
- FSTAB3** Front stiff anti-roll bar
- RAL19** Rear bogie design capacity 19 tonnes
- RAL20.5** Rear bogie design capacity 20.5 tonnes
- RAL22.5** Rear bogie design capacity 22.5 tonnes
- RSTAB1** Rear anti-roll bar
- RSTAB2** Rear anti roll bar medium stiffness
- RSTAB3** Rear stiff anti-roll bar
- RALIM10** Rear axle load limiter, 10 tonnes
- RALIM105** Rear axle load limiter, 10.5 tonnes
- RALIM115** Rear axle load limiter, 11.5 tonnes
- RALIM95** Rear axle load limiter, 9.5 tonnes
- ACTST-TO** Volvo Dynamic Steering (VDS) with with extra electronic pump
and torque overlay
- ASFE-BAS** Active steering feature - Basic - Volvo Dynamic Steering only
- ASFE-OG** Active steering feature - Volvo Dynamic Steering with stability
assist - oversteer
- ASFE-PO** Active steering feature - Volvo Dynamic Steering with personal
settings and stability assist
- ASFE-PS** Active steering feature - Volvo Dynamic Steering with personal
settings
- PSS-SING** Single power steering system

MODEL RANGE

FM 13 6x2 Tractor - Tag - Rear Air Suspension FM 62 TT3HA

■ PSP-FIX	Power steering pump with fixed displacement	□ TB-L80	Toolbox 800 mm, left side
□ PSP-VAR	Power steering pump with variable displacement	□ TB-R80	Toolbox 800 mm, right side
■ EBS-MED	EBS medium package including "hill" hold function	□ SUP-BAS	EC approved chassis side guards
■ RST-AIR	Rear air suspension	□ SUP-LOW	EC approved low chassis side guards
□ RST-AIR4	Rear air suspension with reinforced air bellows	□ CHAIN-S	Snow chains
■ FBREG-E	Front regulating brake valve, EBS	□ HOOK-SC	Snow chain hooks
■ SUSPL-EC	Remote electronic control on wander-lead for air suspension levelling	■ TOWF-NO1	One front towing device
■ FRAME266	Frame rail section external height 266 mm	□ TOWF-NO2	Two front towing devices
□ FRAME300	Frame rail section external height 300 mm	■ RFEC-B	Rear frame end, bent down - standard for tractor vehicles
□ FST7070	Frame thickness - web and flange 7.0mm	□ TOWR-ONE	Towing hitch attached to rear crossmember
■ FST8080	Frame thickness - web and flange 8.0mm	□ TREL15	Single 15 pole electrical trailer connector - ADR certified
□ FIL-EEEB	Inner liner from end of engine to end of bogie	□ TREL7	7 pole - 24N trailer electrical suzie
□ FIL-TXEB	Inner liner from gearbox member to end of bogie	■ TREL7-7	24N and 24S trailer electrical suzies
□ BBOX-EF	Battery box located in the end of frame	□ TBC-DUO	Duomatic type air line connectors
■ BBOX-L	Battery box located on left hand side	□ TBC-EC	Palm coupling type air line connectors
□ BATS-D	Dual energy battery system - 2 living batteries and 2 starter batteries.	■ TBC-GBR	'C' and 'CA' type air line connectors
■ BATS-S	Single energy battery system (2 batteries)	□ TRBR-HCF	Full pressure hand controlled trailer brake
□ 2BAT210B	2 x 210 Ah capacity Gel batteries	■ TRBR-STA	Stationary trailer brake control
■ 2BATT170	2 x 170 Ah capacity batteries	□ TRB-STRE	Stretch Brake - Automatic low speed trailer brake activation to avoid jack-knifing and improve steerability
□ 2BATT225	2 x 225 Ah capacity batteries	■ RFEND-B	Three piece EC approved rear mud wings and spray flaps
■ BATTAMP	Battery voltage and ampere gauge	■ RFH-BAS	Basic rear wing height
□ BATTIND	Battery charge indication	□ RFH-HIG	High rear wing height - higher wing tops
□ ADR2	ADR package for transportation of dangerous goods on road (Note does NOT include safe loading pass package if required this is quoted seperately)	□ RFH-LOW	Lower rear wing height - shallower wing tops
□ MSWI-A	Main switch - ADR switch circuit shut down	□ ATANK-AL	Aluminium air tanks
■ MSWI-C	Main switch - Chassis mounted toggle switch by battery box	■ ATANK-ST	Steel air tanks
□ MSWI-R	Main switch - Key fob operated remote controlled	■ TL-LED	LED Tail lights
■ R330A71	Right aluminium 710 mm D-shaped fuel tank, 330 litres volume Min volume 150l Max volume 810l	□ BLIGHT-E	Emergency brake light
■ UL-FUEL	Without left fuel tank Min volume 160l Max volume 770l	WHEELS & TYRES	
□ ADTP-BC	AdBlue tank behind/under cab on right hand side	□ RT-AL	Alcoa brushed aluminium rims with standard holes for long stud fixing on all axles
□ ADTP-L	AdBlue tank on left hand side	□ RT-ALDP	Alcoa Dura-Bright EVO aluminium rims with standard holes long stud fixing on all axles, requires cleaning with a ph neutral solution - washing up liquid.
■ ADTP-R	AdBlue tank on right hand side	□ RT-ALDPD	Alcoa Dura-Bright EVO aluminium rims with countersunk holes for short stud fixing on all axles, requires cleaning with a ph neutral solution - washing up liquid.
□ ADB048	AdBlue tank usable volume 48 litres	□ RT-ALDU	Alcoa brushed aluminium rims with countersunk holes for short stud fixing on all axles
□ ADB050	AdBlue tank usable volume 50 litres - under cab	■ RT-STEEL	Steel rims on all axles
■ ADB064	AdBlue tank usable volume 64 litres	□ WCAP	Aerodynamic hub caps
□ ADB068	AdBlue tank usable volume 68 litres	□ BRREC001	Bridgestone ECOPIA H - Energy rating C
□ ADB090	AdBlue tank usable volume 90 litres	□ COREC002	Continental ECOPLUS HS3/HD3 - Energy rating B or C depending on size
□ ADB100	AdBlue tank usable volume 100 litres	□ COREC003	Continental Efficient Pro S/D - Fuel Tyre Recommendation 3 Reduced mileage compared to Conti EcoPlus long haul pattern please consider when selecting these tyres.
□ ADTC-BF	AdBlue tank cover with satin alloy look decorative cover	□ GYREC001	Good Year FUELMAX S/HL/D - Energy rating B or C depending on size
■ FCAP-L	Locking fuel filler cap	□ GYREC002	Good Year FUELMAX S/D - Energy rating B or C depending on size
■ FUFF-AS	Fuel filling anti-spillage device	□ GYREC003	Good Year FUELMAX S/(O)/D - Fuel tyre Recommendation 3
□ FUFF-ATS	Fuel filling anti-theft and anti-spillage devices	□ MIREC002	Michelin XZA2/X-LINE Energy - Fuel tyre Recommendation 2
□ ESH-LEFT	Horizontal silencer, left exhaust outlet	□ MIREC003	Michelin X-LINE Energy - Fuel tyre Recommendation 3
■ ESH-REAR	Horizontal silencer, rear exhaust outlet	□ MIREC004	Michelin X Line Energy F/D2 - Energy rating A
□ ESH-RIGH	Horizontal silencer, right exhaust outlet	□ SPWT-D	Spare wheel & tyre with rear tyre pattern
□ ESH-VERT	Horizontal silencer, vertical exhaust outlet	□ SPWT-F	Spare wheel & tyre with front tyre pattern
□ EXST-SSP	Stainless steel exhaust stack - NOT polished	□ SWCP-LF	Spare wheel carrier on left side of chassis ahead of rear axle
□ EXST-ST	Steel exhaust stack	□ SWCP-RF	Spare wheel carrier on right side of chassis ahead of rear axle
□ WHC-FIX2	Two fixed wheel chocks	□ SWCP-T	Spare wheel supplied temporarily strapped to chassis
□ WHC-FOL2	Two foldable wheel chocks	□ SWCP-TF	Temporary spare wheel carrier on top of chassis frame
□ WHCP-F	Wheel chock(s) stored in the front part of the vehicle	□ JACK-12T	12 tonne bottle jack
□ WHCP-M	Wheel chock(s) stored in the middle part of the vehicle		
□ WHCP-T	Transport mounted wheel chock(s) stored in cab outer luggage locker		

■ Standard Equipment

□ Optional Equipment

For more detailed information about cab and powertrain equipment, please refer to separate specification sheets.

For all possible options and combinations of options please consult your Volvo sales contact who can create a specification to match your requirements using the Volvo Sales Support system (VSS).

The factory reserves the right to modify design and change equipment without previous notification. The specification can vary from country to country.

MODEL RANGE

FM 13 6x2 Tractor - Tag - Rear Air Suspension FM 62 TT3HA

<input type="checkbox"/>	JACK-15T	15 tonne bottle jack	<input type="checkbox"/>	HPE-F101	Parker F1-101, engine mounted, fixed displacement, single flow, engine mounted hydraulic pump
<input type="checkbox"/>	JACK-20T	20 tonne bottle jack	<input type="checkbox"/>	HPE-F41	Parker F1-41, engine mounted, fixed displacement, single flow, engine mounted hydraulic pump
<input checked="" type="checkbox"/>	TOOL-BAS	Basic Toolkit	<input type="checkbox"/>	HPE-F51	Parker F1-51, engine mounted, fixed displacement, single flow, engine mounted hydraulic pump
<input type="checkbox"/>	TOOLKIT	Complete tool kit	<input type="checkbox"/>	HPE-F61	Parker F1-61, engine mounted, fixed displacement, single flow, engine mounted hydraulic pump
<input type="checkbox"/>	INFLAHOS	Tyre inflation hose	<input type="checkbox"/>	HPE-F81	Parker F1-81, engine mounted, fixed displacement, single flow, engine mounted hydraulic pump
<input type="checkbox"/>	GAUGE-TP	Tyre pressure gauge	<input type="checkbox"/>	HPE-T53	Parker F2-53/53, engine mounted, Fixed displacement, Twin flow engine mounted hydraulic pump
<input type="checkbox"/>	OBDEP-C	Euro 6 Step C emission level	<input type="checkbox"/>	HPE-T70	Parker F2-70/35, engine mounted, Fixed displacement, Twin flow engine mounted hydraulic pump
<input type="checkbox"/>	OBDEP-D	Euro 6 Step D emission level	<input type="checkbox"/>	HPE-V45	Parker VP1-45, variable displacement, single flow, engine mounted hydraulic pump
DRIVELINE EQUIPMENT			<input type="checkbox"/>	HPE-V75	Parker VP1-75, variable displacement, single flow, engine mounted hydraulic pump
<input type="checkbox"/>	ASO-C	Crawler gear - Ratio direct top gearbox 19:1 Ratio Overdrive gearbox 17:1	<input type="checkbox"/>	PTPT-D	Powertronic PTO, 1 front/upper DIN connection for plug-in pump (max. 850 Nm)
<input type="checkbox"/>	ASO-ULC	Ultra low crawler and crawler gear - Ratios direct top gearbox 32:1 and 19:1 Ratios Overdrive box 32:1 and 17:1	<input type="checkbox"/>	PTPT-F	Powertronic PTO, 1 front/upper rear facing SAE flange conn. for prop shaft (max.850 Nm)
<input type="checkbox"/>	TRAP-HD	Reinforced gearbox application	<input type="checkbox"/>	PTR-D	Gearbox PTO for plug-in pump, 0.71xeng speed
<input type="checkbox"/>	TP-CON	Construction Package	<input type="checkbox"/>	PTR-DH	Gearbox driven high speed PTO for one plug-in hydraulic pump
<input type="checkbox"/>	TP-DIST	Distribution Package	<input type="checkbox"/>	PTR-DM	Gearbox driven medium speed PTO for one plug-in hydraulic pump
<input type="checkbox"/>	TP-LONG	Long Haul Package	<input type="checkbox"/>	PTR-F	Gearbox driven PTO with rear flange connection
<input type="checkbox"/>	AMSO-AUT	Enhanced I-shift software with manual shift available in auto mode and kickdown facility on accelerator pedal	<input type="checkbox"/>	PTR-FH	Gearbox driven high speed PTO with SAE drive flange
<input type="checkbox"/>	AVO-ENH	Enhanced software for off road driveability and starting	<input type="checkbox"/>	PTR-FL	Gearbox driven low speed PTO with SAE drive flange
<input type="checkbox"/>	APF-ENH	I-shift enhanced PTO functions	<input type="checkbox"/>	PTRD-D	Gearbox driven HIGH SPEED PTO for two plug-in hydraulic pumps
<input type="checkbox"/>	CD43-O	Dual plate clutch, plate diameter 430 mm	<input type="checkbox"/>	PTRD-D1	PTRD-D1 Gearbox driven HIGH SPEED PTO (1 SAE flange & 1 plug-in hydraulic pump)
<input checked="" type="checkbox"/>	CS43B-O	Single plate 430mm (17") clutch	<input type="checkbox"/>	PTRD-D2	Gearbox driven HIGH SPEED PTO (2 SAE flanges & 1 plug-in hyd pump)
<input type="checkbox"/>	RET-TH	Gearbox mounted retarder	<input type="checkbox"/>	PTRD-F	PTO with 1 DIN + 1 flange connection rear, manual gearbox
<input type="checkbox"/>	RET-TPT	Hydraulic Retarder for Powertronic gearbox	<input type="checkbox"/>	HPG-F101	Parker F1-101 gearbox mounted, fixed displacement, single flow, hydraulic pump
<input type="checkbox"/>	TC-HWO	Automatic gearbox oil cooler - water to oil	<input type="checkbox"/>	HPG-F41	Parker F1-41 gearbox mounted, fixed displacement, single flow, hydraulic pump
<input type="checkbox"/>	TC-MAOH2	Extra high performance transmission oil cooler - air to oil with front mounted radiator	<input type="checkbox"/>	HPG-F51	Parker F1-51 gearbox mounted, fixed displacement, single flow, hydraulic pump
<input type="checkbox"/>	TC-MWO	Basic transmission oil cooler - water to oil	<input type="checkbox"/>	HPG-F61	Parker F1-61 gearbox mounted, fixed displacement, single flow, hydraulic pump
<input type="checkbox"/>	TC-MWOH2	High performance transmission oil cooler - water to oil	<input type="checkbox"/>	HPG-F81	Parker F1-81 gearbox mounted, fixed displacement, single flow, hydraulic pump
<input type="checkbox"/>	2COM1100	Two cylinder, air compressor, 1100 litres per minute	<input type="checkbox"/>	EIDLESD	Engine idle shut down
<input checked="" type="checkbox"/>	2COMP900	Two cylinder, air compressor, 900 litres per minute	<input type="checkbox"/>	DTRI-PER	Dashboard in darker peregrine greyish brown. Steering wheel grey and door panels in light beige for FH and black for FH16.
<input type="checkbox"/>	CLU-AIRC	Clutchable air compressor	<input type="checkbox"/>	STWPOS-L	LEFT HAND DRIVE
<input checked="" type="checkbox"/>	AIRIN-HI	Roof mounted air intake behind cab on left hand side	<input checked="" type="checkbox"/>	STWPOS-R	RIGHT HAND DRIVE
<input type="checkbox"/>	AIRIN-LO	Low level air intake behind cab on left hand side	<input type="checkbox"/>	STWM-LE	Leather steering wheel
<input type="checkbox"/>	ACL1ST-S	Two stage air filter	<input type="checkbox"/>	STGW-AD2	Adjustable steering wheel with neck tilt
<input checked="" type="checkbox"/>	24AL110B	110 amp alternator	<input checked="" type="checkbox"/>	STGW-ADJ	Adjustable steering wheel
<input type="checkbox"/>	24AL120B	120 amp alternator	<input checked="" type="checkbox"/>	AIRBAG	SRS Driver's air bag
<input type="checkbox"/>	24AL150B	150 amp alternator	<input checked="" type="checkbox"/>	DRC-AMII	DPF Regeneration control switch - for manual and switching off regeneration
<input checked="" type="checkbox"/>	CCV-C	Closed crankcase engine ventilation	<input type="checkbox"/>	1DAYDIG	Continental VDO DTCO 3.0 digital tachograph This tachograph can ONLY offer remote download if the option of Dynafleet or an FMS gateway has been specified with this order.
<input type="checkbox"/>	CCV-O	Open crankcase engine breather	<input checked="" type="checkbox"/>	1DAYDIG2	Continental VDO DTCO 4.0 smart tachograph This tachograph can ONLY offer remote download if the option of Dynafleet or an FMS gateway has been specified with this order.
<input type="checkbox"/>	CCV-OX	Closed crankcase ventilation for cold markets	<input type="checkbox"/>	1DAYDIGP	Continental VDO DTCO 3.0 digital tachograph For vehicles with long lead time - this includes prep kit for the
<input checked="" type="checkbox"/>	PRIM-EL	Electrical priming pump			
<input type="checkbox"/>	PRIM-MAN	Manual priming pump			
<input type="checkbox"/>	FUEQ-EH	Fuel line electric heater			
<input type="checkbox"/>	AF-R	Hot fuel recirculation heated fuel filter			
<input type="checkbox"/>	FUEFE2LW	Large engine mounted dual fuel filter with water separator			
<input checked="" type="checkbox"/>	FUEFE2SW	Small engine mounted dual fuel filter with water separator			
<input type="checkbox"/>	EST-AID	Air inlet manifold starting heater element			
<input type="checkbox"/>	220EBH15	220V/1.5Kw electric engine block heater			
<input type="checkbox"/>	PTER-100	Rear engine mounted power-take-off with DIN 100 / ISO 7646 flange			
<input type="checkbox"/>	PTER-DIN	Rear engine mounted PTO with DIN5462 (female) splined shaft for a close coupled pump. Models with 3 steering axles will use this to drive the steering pump (AUXPSP)			
<input type="checkbox"/>	PTER1400	Rear engine mounted power-take-off with SAE 1410 flange			
<input checked="" type="checkbox"/>	Standard Equipment		<input type="checkbox"/>	Optional Equipment	

For more detailed information about cab and powertrain equipment, please refer to separate specification sheets.

For all possible options and combinations of options please consult your Volvo sales contact who can create a specification to match your requirements using the Volvo Sales Support system (VSS).

The factory reserves the right to modify design and change equipment without previous notification. The specification can vary from country to country.

MODEL RANGE

FM 13 6x2 Tractor - Tag - Rear Air Suspension FM 62 TT3HA

	retrofit of DTCO 4.0 tachograph. For updating to new legal demand for trick registration from 15th June 2019. This tachograph can ONLY offer remote download if the option of Dynafleet or an FMS gateway has been specified with this order.	<input type="checkbox"/> WRITEPAD	Writing pad
<input type="checkbox"/> ARSL	Additional road speed limit - switch in dashboard	<input type="checkbox"/> UPHTRI10	Seats: Black embossed textile insert with light grey sides, black vinyl side bolster with blue vinyl side insert. Interior trim: Raven black bunk and curtains & blue textile side walls
<input type="checkbox"/> CRUIS-E	Eco cruise control (with eco-roll and I-cruise, controls in steering wheel)	<input type="checkbox"/> UPHTRI11	Seats: Light grey embossed textile insert, black raven metallic vinyl bolster with red vinyl side insert. Interior trim: Raven black bunk and curtains & grey vinyl side walls
<input checked="" type="checkbox"/> CRUISEC	Cruise control, standard	<input type="checkbox"/> UPHTRI12	Seats: Blue soft textile insert, black vinyl bolster. Interior trim: Raven black bunk and curtains & blue textile side walls
<input checked="" type="checkbox"/> ESP-BAS1	Electronic Stability Control	<input type="checkbox"/> UPHTRI13	Seats: Dark grey leather insert and black leather bolster. Interior trim: Raven black bunk and curtains & grey vinyl side walls
<input type="checkbox"/> ESPC-RO	ESP (Electronic Stability Program) functionality control - Reduced / Off	<input type="checkbox"/> UPHTRI14	Seat: Dark grey leather insert and black leather bolster. Interior trim: Raven black bunk and curtains & blue textile side walls
<input type="checkbox"/> HWSS-ACB	Adaptive cruise control with forward collision warning and advanced emergency braking	<input checked="" type="checkbox"/> DST-CF4	Driver seat, comfort, suspended, belt in seat
<input checked="" type="checkbox"/> HWSS-FCB	Forward collision warning with basic cruise control and advanced emergency brake	<input checked="" type="checkbox"/> DST-CF5	Driver seat, comfort, suspended, belt in seat, electrically heated
<input checked="" type="checkbox"/> LSS-DW	Lane departure warning system	<input type="checkbox"/> DST-CF6	Driver seat, comfort, suspended, belt in seat, electrically heated, ventilated
<input type="checkbox"/> LCS	Lane change support	<input type="checkbox"/> SBD-RED	Red seat belts
<input type="checkbox"/> DAS-W	Driver Alert Support system	<input type="checkbox"/> SBPRE-DS	Driver seat belt pretensioner
<input type="checkbox"/> RSENS-W	Rain sensing windscreen wipers	<input checked="" type="checkbox"/> PST-BAS1	Passenger seat - Fixed non suspended fold up with seatbelt mounted in cab
<input type="checkbox"/> CU-ECC	Electrically controlled air conditioning with sun sensor	<input type="checkbox"/> PST-BENC	Bench passenger seat
<input type="checkbox"/> CU-ECC2	Electrically controlled air conditioning with sun sensor, mist sensor, air quality sensor and carbon filter	<input type="checkbox"/> PST-CF4	Passenger seat - Comfort suspended with seatbelt mounted in seat
<input checked="" type="checkbox"/> CU-MCC	Climate unit with manual controlled air conditioning	<input type="checkbox"/> PST-CF5	Passenger seat - Comfort suspended & heated with seatbelt mounted in seat
<input checked="" type="checkbox"/> IMMOBIL	Thatcham H2 approved immobiliser	<input type="checkbox"/> PST-STD2	Passenger seat - Fixed non suspended with seatbelt mounted in cab
<input type="checkbox"/> ALARM-B	Thatcham H1 approved vehicle alarm - Cab only	<input type="checkbox"/> PST-STD4	Passenger seat - Standard suspended with seatbelt mounted in cab
<input type="checkbox"/> ALARM-E	Enhanced vehicle alarm - Thatcham H1 approved - Cab plus external sensor for body/trailer	<input type="checkbox"/> SBPRE-PS	Passenger seat belt pretensioner
<input type="checkbox"/> ALCOLOCK	Alcolock	<input type="checkbox"/> ARM-DBPS	Two armrests on driver seat and one (outer) on passenger seat
<input type="checkbox"/> PHONE-PK	Telephone preparation kit (antenna, antenna attachm. cable incl.)	<input type="checkbox"/> ARMRE-BB	Two armrests on both driver and passenger seat.
<input type="checkbox"/> WLIFT-AD	Electrical window lift, automatic up/down driver side	<input type="checkbox"/> ARMRE-DB	Two armrests, on driver seat only
<input checked="" type="checkbox"/> WLIFT-EB	Electrical window lift	<input type="checkbox"/> ARMRE-PB	Two armrests, on passenger seat only
<input type="checkbox"/> WLIFT-ME	Mechanical window lift	<input type="checkbox"/> ARMRE-PS	Single armrest (next to driver) on passenger seat
<input type="checkbox"/> ISUNS-BS	Side interior sun visor on both sides	<input type="checkbox"/> ARU-BAS	Vinyl upholstered armrest
<input checked="" type="checkbox"/> ISUNS-DS	Driver's side interior sun visor	<input type="checkbox"/> ARU-LEA	Leather upholstered armrest
<input checked="" type="checkbox"/> ISUNF-B	Interior front sun visor without mirror	<input checked="" type="checkbox"/> FMAT-RUB	Rubber floor mats
<input type="checkbox"/> ISUNF-MD	Interior front sun visor with mirror on driver side	<input checked="" type="checkbox"/> FMAT-TX2	Textile and rubber floor mats
<input type="checkbox"/> ISUNF-RE	Electrically operated textile interior sun blind	<input type="checkbox"/> LBK-RES	Foldable rest bunk
<input type="checkbox"/> ISUNF-RM	Manually operated textile interior sun blind	<input checked="" type="checkbox"/> LBK70	Lower bunk 700 x2000 mm, fixed
<input type="checkbox"/> ADFS	Two extra DIN slots in front shelf - can be fitted with card or drawer available as an accessory	<input type="checkbox"/> ULBK	Without lower bunk
<input checked="" type="checkbox"/> BUPALARM	Reverse alarm	<input type="checkbox"/> MATL-FI	Firm lower bunk pocket sprung mattress
<input type="checkbox"/> BUPMON	Back up monitor with built in 7" screen on dash and one colour camera supplied loose for fitment by bodybuilder.	<input checked="" type="checkbox"/> MATL-SF	Lower flexizone mattress - semi-firm, pocket springs up to 100kg - 16 stone
<input type="checkbox"/> RTOLL-PK	Road toll PREPARATION kit for trucks operating with "Toll Collect" in Germany	<input type="checkbox"/> MATL-SO	Lower flexizone mattress - soft, pocket springs up to 85kg - 13.5 stone
<input type="checkbox"/> LOADIND	Load indicator with central dashboard display	<input type="checkbox"/> OLMAT-BA	35mm mattress overlay protector
<input type="checkbox"/> REMC-MF	Multi-functio wireless remote control	<input type="checkbox"/> OLMAT-PR	50mm premium mattress overlay protector
<input type="checkbox"/> FIREXT3S	3kg fire extinguisher mounted on seat base	<input type="checkbox"/> TBK60F	Fixed foldable top bunk 600 x 1900mm
<input type="checkbox"/> WARNVEST	High visibility warning vest - no sleeves	<input type="checkbox"/> TBK70F	Fixed foldable top bunk 700 x 1900mm
<input type="checkbox"/> AIDKIT	First aid kit	<input type="checkbox"/> PH-CAB2	1.8kW Air to air night heater
<input type="checkbox"/> AIDKIT1B	First aid kit	<input type="checkbox"/> PH-ENGCA	Engine and cab night heater
<input type="checkbox"/> WARNLAMP	Portable warning lamp	<input type="checkbox"/> PH-SS	Short stop heater
<input type="checkbox"/> LAMP-IN	Inspection lamp	<input type="checkbox"/> SLCP-BAS	Basic sleeper control panel - includes interior light, parking heater, roof hatch and door lock
<input type="checkbox"/> BULBKIT	Bulb and fuse kit	<input type="checkbox"/> SAFE	Safe box for driver's personal items
<input checked="" type="checkbox"/> Standard Equipment		<input type="checkbox"/> ETSB-F	Storage on engine tunnel - on front top
<input type="checkbox"/> Optional Equipment			

For more detailed information about cab and powertrain equipment, please refer to separate specification sheets.

For all possible options and combinations of options please consult your Volvo sales contact who can create a specification to match your requirements using the Volvo Sales Support system (VSS).

The factory reserves the right to modify design and change equipment without previous notification. The specification can vary from country to country.

MODEL RANGE

FM 13 6x2 Tractor - Tag - Rear Air Suspension FM 62 TT3HA

- ETSB-FR** Storage on engine tunnel - on front top and at rear cab wall
 - ETSB-FRS** Storage on engine tunnel - on front top & at rear cab wall & storage recessed into tunnel on right hand side
 - ETSB-FS** Storage on engine tunnel - on front top and storage recessed into tunnel on right hand side
 - ETSB-R** Storage on engine tunnel - box at rear cab wall
 - ETSB-RS** Storage on engine tunnel - at rear cab wall and storage recessed into tunnel on right hand side
 - ETSB-S** Storage on engine tunnel - recessed into tunnel on right hand side
 - RUS-BAS** Rear cab upper storage 154 litres - 300 mm high
 - RUS-HIG** Rear cab upper storage 245 litres - 440 mm high
 - TABLE** Folding and height adjustable table - on lower bunk
 - REF-ICPK** Refrigerator preparation kit, engine tunnel mounted
 - REFR-RUS** 28 litre rear upper wall mounted refrigerator with dividers
 - BOTH-D** One bottle holder under dashboard centre section
 - COFMA-PK** Coffee maker, preparation kit.
 - INLI-BAS** Basic white interior lights
 - INLI-NL** Interior white and red night light with no dimmer
 - INLI-NLD** Interior white and red night light with dimmer function
 - ARL-FLEX** Two flexible reading lamps (snake lamps)
 - RH-ECS** Glass roof hatch - Electrically operated
 - RH-EE** Without roof hatch
 - RH-ETR** Roof & escape hatch - Electrically operated, tinted glass with rear opening
 - RH-MSR** Steel roof hatch - Manually operated with rear opening
 - RH-MTR** Roof & escape hatch - Manually operated, tinted glass with rear opening
 - URH** Without roof hatch
 - SWIND-BS** Extra side window on both sides behind "B" pillar
 - SWIND-PS** Rear side window, passenger side
 - VANMIR** Vanity mirror in front shelf
 - AS-FUS** Extra shelf in front upper storage compartments
 - INFOT-PK** Preparation kit for the mounting of a flat screen TV in cab above the driver's door, includes bracket, electrical and speaker connections
- CAB EXTERIOR**
- PAICS-B** Basic cab paint - mirrors, sunvisor, instep and bumper supplied in natural finish - grey
 - PAICS-C** Complete cab - mirrors, insteps, sunvisor, and bumper finished in cab colour
 - GLAS-TIN** Tinted windows.
 - AWIND-RF** Rear window
 - DGLAS-L** Laminated door glass
 - LOCK-MAN** Manual door locking
 - LOCK-MRP** Manual door locking with internal remote control (from driver side) of passenger door
 - LOCK-REM** Central locking with remote control
 - BUMP-B** Plastic front bumper
 - BUMP-B2** Steel front bumper
 - BUMP-SP** Front bumper spoiler
 - GUARD-EH** Engine guard to protect sump and engine hoses
 - BUGNET** Insect screen in front of radiator
 - CTILT-P-E** Electrically operated hydraulic cab tilt
 - CTILT-P-M** Manually operated hydraulic cab tilt
 - FCABS-A** Front cab - Air suspension
 - FCABS-M** Front cab - Mechanical spring suspension
 - RCABS-A** Rear cab suspension - Air
 - RCABS-M** Rear cab suspension - Mechanical spring
 - MIRCOMF2** Basic electrically heated and operated mirrors FMX style with wide angle and passenger kerb mirror, to increase vision side mirrors have no mirror cowlings.
 - MIRCOMFM** Electrically heated and operated main mirror with heated wide angle mirror on both sides, manual kerb view mirror on passenger side
 - MIRSTD2** Basic electrically heated FMX style main with wide angle and passenger kerb mirror, to increase vision side mirrors have no mirror cowlings.
 - MIRSTDFM** Electrically heated exterior mirrors with wide angle mirror on both sides and kerb view mirror on passenger side
 - AMIR-F20** Auxiliary front view mirror with a 200mm radius
 - SUNV-H** External smoke grey sunvisor
 - AD-ROOF** Roof air deflector
 - AD-SIDEL** Side air deflector extension panels
 - AD-SIDES** Short cab side air deflector for rigid bodywork
 - AD-CHASX** Chassis side skirts
 - ADCF-F** Additional black edging on chassis side skirt
 - HL-BASIC** Halogen H7 head lamps
 - HL-BHID** High intensity Bi-Xenon head lamps
 - HL-DBL** Bi-Xenon high intensity discharge and dynamic head lamps. Dipped beam follows the road, activated by a signal from the steering system.
 - HL-CLEAN** Head lamp cleaner - washer jets
 - HLP-ST** Headlamp protection
 - HL-ADJ** Adjustable headlights with switch in the cab
 - DRIVL2** Two spot lamps
 - UDRIVL** Without auxiliary driving lights
 - FOGL-WC** Front fog lights
 - CL-STAT** Static corner lights
 - ASL-RF2** Two Hella H11 70W spotlamps in sign box - only available with the basic headlight and no lower driving lights.
 - ASL-RFPK** Preparation kit for two spotlamps in sign box
 - BEACO2F** Two front roof mounted amber beacon rotating warning lamps
 - BEACO2R** Two rear roof mounted (on accessory bracket) amber beacon flashing warning LED lamps
 - BEACON-P** Roof beacon wire preparation
 - BEACON4** Four roof mounted (2 front/2 rear) amber beacon rotating warning lamps
 - CABPT-R1** Single outlet for roof mounted accessories
 - CABPT-R2** Twin outlets for roof mounted accessories.
 - SPOTP-F** Spotlamp preparation in front, max 280W
 - SPOTP-R** Spotlamp preparation on roof, max 280W
 - SPOTP-RF** Spotlamp preparation on cab roof and in cab front, max 2x280W
 - CSGN-GTR** "Globetrotter" headboard logo
 - HORN-F1S** Single tone Jericho air horn chassis mounted
 - HORN-R2S** Two roof mounted air horns
 - ANT-CBR** Roof mounted antenna for CB radio, single aerial
 - ACCBR-AP** Front, middle & rear roof mounted accessory brackets
 - ACCBR-F** Front roof mounted accessory bracket
 - ACCBR-FM** Front & middle roof mounted accessory brackets
 - ACCBR-FR** Front & rear roof mounted accessory brackets
 - ACCBR-M** Middle roof mounted accessory bracket
 - ACCBR-R** Rear roof mounted accessory bracket
 - ACCBR-RM** Rear & middle roof mounted accessory brackets
 - RFCAR-BC** Rear mudwing carrier, back of cab
 - LADDER** Ladder back of cab
 - REFS-TW** White cab conspicuity markings by packed in cab
 - REFS-TY** Yellow cab conspicuity markings by packed in cab

SUPERSTRUCTURE PREPARATIONS

- Standard Equipment
- Optional Equipment

For more detailed information about cab and powertrain equipment, please refer to separate specification sheets.

For all possible options and combinations of options please consult your Volvo sales contact who can create a specification to match your requirements using the Volvo Sales Support system (VSS).

The factory reserves the right to modify design and change equipment without previous notification. The specification can vary from country to country.

MODEL RANGE

FM 13 6x2 Tractor - Tag - Rear Air Suspension FM 62 TT3HA

- **5WM-ASM** 50mm high 'L' profiles for air actuated sliding 5th wheel
- **5WM-ISOM** 5th wheel subframe 60mm high above chassis frame
L profiles 50mm with 10mm thick plate
- **5WM-LPRO** 5th wheel attached direct to frame with inverted 'L'-profiles
- **5WM-MASM** 50mm high 'L' profiles for manual sliding fifth wheel

- **5WH150** Fifth wheel leg-height 150 mm
- **5WH175** Fifth wheel leg height 175mm
- **5WH185** Fifth wheel leg-height 185 mm
- **5WH195** Fifth wheel leg-height 195mm
- **5WH200** Fifth wheel leg-height 200 mm
- **5WH205** Fifth wheel leg-height 205 mm
- **5WH210** Fifth wheel leg-height 210 mm
- **5WH220** Fifth wheel leg-height 220mm
- **5WH230** Fifth wheel leg-height 230 mm

- **5WT-FO14** Fontaine 150SP2 pressed steel fifth wheel
- **5WT-FO15** Fontaine 3000 lightweight cast fifth wheel with 150SF air operated slider - for moderate duty off road.
Specified fifth wheel position always gives rearmost position.
- **5WT-JO10** Jost JSK 36 pressed fifth wheel
- **5WT-JO8** Jost JSK 37 cast fifth wheel
- **5WT-JO9** Jost JSK 42 cast fixed fifth wheel
- **5WT-SH** SAF-Holland/+GF+ SK-S 36.20 cast fixed fifth wheel

- **5WLM-B** Basic fifth wheel maintenance standard top plate
- **5WLM-L** Low maintenance fifthwheel with nylon top plate

- **5WL-S1** Fifth wheel lubrication - locking mechanism and top plate
- **5WL-S2** Fifth wheel lubrication - locking mechanism

- **TCIND** Trailer connection indication with sensors for height, kingpin and coupling lock

- **RDECK** Catwalk & step
- **RDECK-M** Rear catwalk 760mm

- **SRWL-PK** Wiring preparation for side & rear work/reverse lamps on side of chassis and a three-position switch, maximum 280W
- **SWL-2RA** Two H3 35W amber rear chassis mounted (LH/RH side) working lamps and a 2-position switch (On/Off)
- **SWL-2RW** Two H3 70W white rear chassis mounted (LH/RH side) working lamps and a 2-position switch (On/Off)
- **SWL-PK** Wiring preparation for side work/reverse lamps on side of chassis and a three-position switch, maximum 280W

- **WL-TA1W** White coupling light
- **WLC-H2A** Two H3/70W working lamps with amber coloured lens high mounted back of cab
- **WLC-H2W** Two H3/70W white working lamps high mounted on the back of cab
- **WLC-PKH** Preparation kit, cables and switch for high mounted working lamps back of cab
- **WLC-PKL** Preparation kit, cables and switch for low mounted working lamps back of cab
- **WLC-PKLH** Preparation kit - cables and switch for low and high mounted working lamps back of cab.

- **ECBB-BAS** Body builder electrical centre without body builder module
- **ECBB-HIG** Body builder electrical centre with body builder module

- **BBCHAS1** One 7-pole connector for Body builder interface
- **BBCHAS3** Three 7-pole connectors for Body builder interface

- **BEPR-T2** Body builder electrical software preparation for tipper with remote control

- **EXSTER** External steering control, with VDS and bodybuilder module
- **TD-BAS** Trailer detection WITHOUT LED sensing
- **TD-LED** Trailer detection with LED sensing

- **AUXL-SPK** Electrical preparation kit - wiring and switch for snow plough lights

- **TAILPRE2** Tail lift preparation kit, wireless remote operation
- **TAILPREP** Taillift preparation kit - cab switch and warning in driver display

- **AESW2** Two Body builder bistable electrical switches (marked AUX1 / AUX2)
- **AESW2PK** 2 Body builder bistable el.switches (marked AUX1/AUX2) and prep. for 4 more switches

- **AUXSW-4** Wiring for 4 extra switches (from Body builder electrical centre to switch positions)

DELIVERY SERVICES

- **TGW-3GWL** Telematics gateway with GSM/GPRS/3G modem and wireless lan WLAN
- **FMS-PK** Fleet Management System gateway
- **DRUT** "My Truck App" Two years subscription to driver utility application

VOLVO

Volvo Truck Corporation
volvotrucks.com