

MODEL RANGE

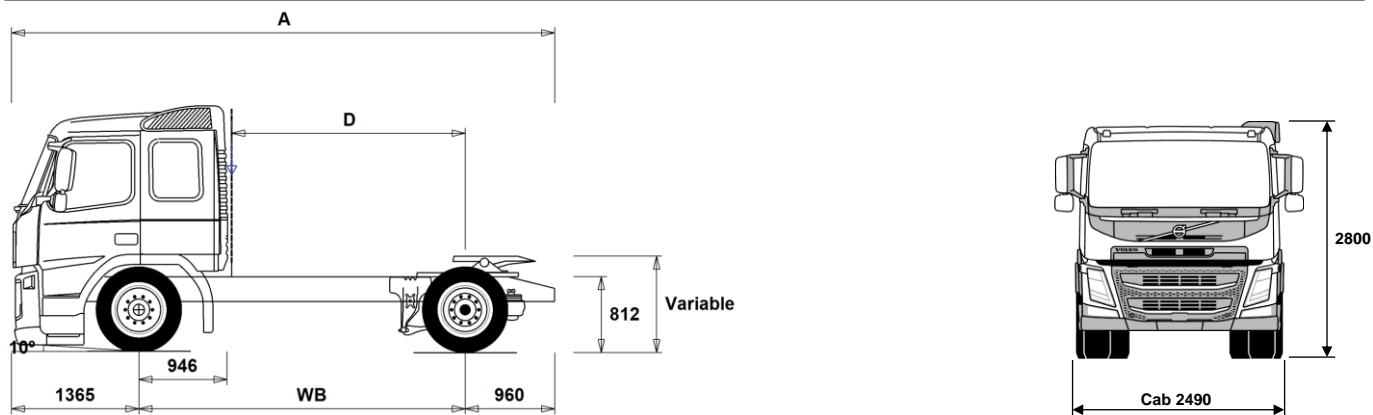

Volvo Trucks. Driving Progress

FM 11 4x2 Tractor - X-Low - Full Air Suspension FM 42 T1XA



Chassis Dimensions [mm]

WB Wheelbase	3500	3600	3800
A Overall Chassis Length	5825	5925	6125
D Center of rear axle to back of cab	2504	2604	2804
F Fifth Wheel Position (EC Directive 96/53)	375	375	375

Chassis Weights [kg]

Front Axle	4445	4440	4450
Rear Axle	1880	1880	1900
Kerb Weight	6325	6320	6350

Turning Diameter [mm]

Turning Circle Diameter Kerb to Kerb	12700	13000	13600
Turning Circle Diameter Wall to Wall	14200	14500	15100

Plated Weights [kg]

	Plated	Design
Gross Vehicle Weight	18000	18600
Gross Combination Weight	40000	44000
Front Axle	6700	7100
Rear Axle	11500	11500

Important Notes

Chassis Dimensions

Cab Height: +416 mm for CAB-HSLP, -169 mm for CAB-LSLP, +554 mm for CAB-XHSL.

Front Axle to Back of Cab: -424 mm for CAB-DAY, -6 mm for CAB-LSLP.

D-measure includes a front clearance of 50 mm and for rigid trucks also a subframe of 100 mm.

Height can vary ± 20 mm for leaf and ± 10 mm for air suspension.

All dimensions are for unladen chassis and any tag axles down.

Weight and dimensions are based upon the following tyres:

Front Axle Tyres: 295/60R22.5

Drive Axle Tyres: 295/60R22.5

Chassis weight includes oil, water, AdBlue, 0 litres fuel and without driver. Kerb weight can vary $\pm 3\%$.

Turning diameters are theoretically calculated.

Legal weights can differ from country to country.

For more detailed weight information, including optional equipment weights, ask your Volvo sales contact to enter your specification into the Volvo Weight Information system (WIS).

Do NOT use this drawing for bodybuilding. Refer to Volvo Bodybuilder Instructions and chassis assembly drawing FM42T1XA.

MODEL RANGE

FM 11 4x2 Tractor - X-Low - Full Air Suspension FM 42 T1XA

TRUCK USE

- **RC-SMOOT** Operating class highway

CORE COMPONENTS

- **CHH-XLOW** Chassis frame height extra low - For a specific loading height always check the unique BEP chassis drawing
- **RAD-GR** Rear air suspension, 1 axle - 1 driven
- **FM-DAY** Day cab - with steel safety cage design
Designed and built to Swedish impact and ECE R29 regulations
- **FM-HSLP** Globetrotter cab - with steel safety cage design
Designed and built to Swedish impact and ECE R29 regulations
- **FM-LSLP** Low sleeper cab - with steel safety cage design
Designed and built to Swedish impact and ECE R29 regulations
- **FM-SLP** Sleeper cab - with steel safety cage design
Designed and built to Swedish impact and ECE R29 regulations
- **FM-XHSL** Globetrotter LXL cab - with steel safety cage design
Designed and built to Swedish impact and ECE R29 regulations
- **EU6SCR** Emission level - Euro 6
- **D11K330** D11K330 10.8l engine developing 330hp at 16-1900rpm.
Peak torque 1600Nm at 950-1400rpm.
- **D11K380** D11K380 diesel engine, 380hp, 1800Nm SCR and EGR
- **D11K430** D11K430 diesel engine, 430hp, 2050Nm SCR and EGR
- **D11K460** D11K460 diesel engine, 460hp, 2200Nm SCR and EGR
- **EBR-EPG** Exhaust brake controlled by steering column switch
- **EBR-EPGC** Exhaust pressure governor for I shift gearbox
- **EBR-VEB** Volvo engine brake and exhaust pressure governor retardation 300kW
- **AT2412F** AT2412F 12-speed "I-shift" automated mechanical gearbox suitable for gross train weights up to 44tonne only refer to sales engineering when used in conjunction with a PTO
- **AT2612F** AT2612F 12-speed "I-shift" automated mechanical gearbox suitable for gross train weights up to 60tonne only refer to sales engineering when used in conjunction with a PTO
- **ATO2612F** ATO2612F 12-speed "I-shift" overdrive automated mechanical gearbox suitable for gross train weights up to 60tonne refer to sales engineering when used in conjunction with a PTO
- **RSS1144A** RS1144A single reduction 11.5t rear axle with differential lock - design GCW 44tonne
- **RSS1344D** RS1344D single reduction rear axle with differential lock - design GCW 44tonne
- **RSS1356** RSS1356 single reduction rear axle with differential lock - design GCW 56 tonne

PACKAGES

- **LHFP-VE** Long Haul Fuel Economy driving package
- **DRIVEFM** Driving package
- **DRIVEFM+** Driving plus package
- **BEDFM** One bed resting package
- **AUDHIG** High Power Audio system: RDS radio with CD player - also playing MP3/WMA files from CD -, with integrated bluetooth phone and USB/Line inputs. FM/AM antenna, speakers in dashboard, doors, and sleeping compartment.
- **MEDIA** AM/FM Bluetooth radio without CD player.
USB and Aux line inputs.
Speakers in dashboard, doors, and sleeping compartment.
7" touch screen with personal apps.
- **MEDIADF** AM/FM Bluetooth radio without CD player.
USB and Aux line inputs.
Speakers in dashboard, doors, and sleeping compartment.
7" touch screen with personal and professional apps.

■ Standard Equipment

□ Optional Equipment

For more detailed information about cab and powertrain equipment, please refer to separate specification sheets.

For all possible options and combinations of options please consult your Volvo sales contact who can create a specification to match your requirements using the Volvo Sales Support system (VSS).

The factory reserves the right to modify design and change equipment without previous notification. The specification can vary from country to country.

- **MEDIANAV** Dynafleet vehicle on-board data display with office internet support.
AM/FM Bluetooth radio without CD player.
USB and Aux line inputs.
Speakers in dashboard, doors, and sleeping compartment.
7" touch screen with personal and professional apps.
Truck based satellite navigation (live updates not included)
- **MEDIANDF** AM/FM Bluetooth radio without CD player.
USB and Aux line inputs.
Speakers in dashboard, doors, and sleeping compartment.
7" touch screen with personal and professional apps.
Truck based satellite navigation (live updates not included)
Dynafleet vehicle on-board data display with office internet support.
- **VISI15** Visibility package
- **VISI15+** Visibility plus package
- **ASAF15** New Active safety package
- CHASSIS**
- **FST-AIR** Front suspension type - air
- **FAL7.1** Front axle design capacity 7.1 tonnes
- **FAL7.5** Front axle design capacity 7.5 tonnes
- **FSTAB** Front anti-roll bar
- **RAL11.5** Rear axle design capacity 11.5 tonnes
- **RSTAB3** Rear stiff anti-roll bar
- **ASF-DL1** Air suspension with 1 driving level
- **ASF-DL3** Air suspension with 3 driving levels
- **ACTST-TO** Volvo Dynamic Steering (VDS) with with extra electronic pump and torque overlay
- **ASFE-BAS** Active steering feature - Basic - Volvo Dynamic Steering only
- **ASFE-OG** Active steering feature - Volvo Dynamic Steering with stability assist - oversteer
- **ASFE-PO** Active steering feature - Volvo Dynamic Steering with personal settings and stability assist
- **ASFE-PS** Active steering feature - Volvo Dynamic Steering with personal settings
- **PSS-SING** Single power steering system
- **PSP-FIX** Power steering pump with fixed displacement
- **PSP-VAR** Power steering pump with variable displacement
- **EBS-MED** EBS medium package including "hill" hold function
- **AUXPARK** Additional spring parking brakes
- **FRAME266** Frame rail section external height 266 mm
- **FST7070** Frame thickness - web and flange 7.0mm
- **FST8080** Frame thickness - web and flange 8.0mm
- **BBOX-L** Battery box located on left hand side
- **2BAT210B** 2 x 210 Ah capacity Gel batteries
- **2BATT170** 2 x 170 Ah capacity batteries
- **2BATT225** 2 x 225 Ah capacity batteries
- **BATTAMP** Battery voltage and ampere gauge
- **BATTIND** Battery charge indication
- **ADR2** ADR package for transportation of dangerous goods on road (Note does NOT include safe loading pass package if required this is quoted separately)
- **MSWI-A** Main switch - ADR switch circuit shut down
- **MSWI-C** Main switch - Chassis mounted toggle switch by battery box
- **MSWI-R** Main switch - Key fob operated remote controlled
- **R315A56** Right aluminium 560 mm D-shaped fuel tank, 315 litres volume
Min volume 255l
Max volume 630l
- **UL-FUEL** Without left fuel tank
Min volume 160l
Max volume 505l

MODEL RANGE

FM 11 4x2 Tractor - X-Low - Full Air Suspension FM 42 T1XA

- ADTP-BC** AdBlue tank behind/under cab on right hand side
 - ADTP-L** AdBlue tank on left hand side
 - ADTP-R** AdBlue tank on right hand side
 - ADB048** AdBlue tank usable volume 48 litres
 - ADB050** AdBlue tank usable volume 50 litres - under cab
 - ADB068** AdBlue tank usable volume 68 litres
 - ADTC-BF** AdBlue tank cover with satin alloy look decorative cover
 - FCAP-L** Locking fuel filler cap
 - FUFF-AS** Fuel filling anti-spillage device
 - FUFF-ATS** Fuel filling anti-theft and anti-spillage devices
 - ESH-LEFT** Horizontal silencer, left exhaust outlet
 - ESH-REAR** Horizontal silencer, rear exhaust outlet
 - ESH-VERT** Horizontal silencer, vertical exhaust outlet
 - EXST-SSP** Stainless steel exhaust stack - NOT polished
 - WHC-FIX1** One fixed wheel chock
 - WHC-FIX2** Two fixed wheel chocks
 - WHC-FOL1** One foldable wheel chock
 - WHC-FOL2** Two foldable wheel chocks
 - WHCP-F** Wheel chock(s) stored in the front part of the vehicle
 - WHCP-M** Wheel chock(s) stored in the middle part of the vehicle
 - WHCP-T** Transport mounted wheel chock(s) stored in cab outer luggage locker
 - CHAIN-S** Snow chains
 - TOWF-NO1** One front towing device
 - TOWF-NO2** Two front towing devices
 - RFEC-B** Rear frame end, bent down - standard for tractor vehicles
 - TREL15** Single 15 pole electrical trailer connector - ADR certified
 - TREL7** 7 pole - 24N trailer electrical suzie
 - TREL7-7** 24N and 24S trailer electrical suzies
 - TBC-DUO** Duomatic type air line connectors
 - TBC-EC** Palm coupling type air line connectors
 - TBC-GBR** 'C' and 'CA' type air line connectors
 - TRBR-HCF** Full pressure hand controlled trailer brake
 - TRBR-STA** Stationary trailer brake control
 - TRB-STRE** Stretch Brake - Automatic low speed trailer brake activation to avoid jack-knifing and improve steerability
 - RFEND-B** Three piece EC approved rear mud wings and spray flaps
 - RFH-BAS** Basic rear wing height
 - RFH-HIG** High rear wing height - higher wing tops
 - RFH-LOW** Lower rear wing height - shallower wing tops
 - ATANK-AL** Aluminium air tanks
 - ATANK-ST** Steel air tanks
 - TL-LED** LED Tail lights
 - BLIGHT-E** Emergency brake light
- ### WHEELS & TYRES
- RT-AL** Alcoa brushed aluminium rims with standard holes for long stud fixing on all axles
 - RT-ALDP** Alcoa Dura-Bright EVO aluminium rims with standard holes long stud fixing on all axles, requires cleaning with a ph neutral solution - washing up liquid.
 - RT-ALDPD** Alcoa Dura-Bright EVO aluminium rims with countersunk holes for short stud fixing on all axles, requires cleaning with a ph neutral solution - washing up liquid.
 - RT-ALDU** Alcoa brushed aluminium rims with countersunk holes for short stud fixing on all axles
 - RT-STEEL** Steel rims on all axles
 - WCAP** Aerodynamic hub caps
 - BRREC001** Bridgestone ECOPIA H - Energy rating C
 - COREC002** Continental ECOPLUS HS3/HD3 - Energy rating B or C depending on size
 - GYREC001** Good Year FUELMAX S/H/L/D - Energy rating B or C depending on size
 - GYREC002** Good Year FUELMAX S/D - Energy rating B or C depending on size
 - MIREC003** Michelin X-LINE Energy - Fuel tyre Recommendation 3
 - SPWT-D** Spare wheel & tyre with rear tyre pattern
 - SPWT-F** Spare wheel & tyre with front tyre pattern
 - SWCP-T** Spare wheel supplied temporarily strapped to chassis
 - SWCP-TP** Temporary spare wheel carrier on top of chassis frame
 - JACK-12T** 12 tonne bottle jack
 - TOOL-BAS** Basic Toolkit
 - TOOLKIT** Complete tool kit
 - INFLAHOS** Tyre inflation hose
 - GAUGE-TP** Tyre pressure gauge
 - OBDEP-C** Euro 6 Step C emission level
 - OBDEP-D** Euro 6 Step D emission level
- ### DRIVELINE EQUIPMENT
- TRAP-HD** Reinforced gearbox application
 - TP-CON** Construction Package
 - TP-DIST** Distribution Package
 - TP-LONG** Long Haul Package
 - AMSO-AUT** Enhanced I-shift software with manual shift available in auto mode and kickdown facility on accelerator pedal
 - AVO-ENH** Enhanced software for off road driveability and starting
 - APF-ENH** I-shift enhanced PTO functions
 - CS43B-O** Single plate 430mm (17") clutch
 - RET-TH** Gearbox mounted retarder
 - RET-TPT** Hydraulic Retarder for Powertronic gearbox
 - TC-MAOH2** Extra high performance transmission oil cooler - air to oil with front mounted radiator
 - TC-MWO** Basic transmission oil cooler - water to oil
 - TC-MWOH2** High performance transmission oil cooler - water to oil
 - 2COM1100** Two cylinder, air compressor, 1100 litres per minute
 - 2COMP900** Two cylinder, air compressor, 900 litres per minute
 - CLU-AIRC** Clutchable air compressor
 - AIRIN-HI** Roof mounted air intake behind cab on left hand side
 - AIRIN-LO** Low level air intake behind cab on left hand side
 - ACL1ST-S** Two stage air filter
 - 24AL110B** 110 amp alternator
 - 24AL120B** 120 amp alternator
 - 24AL150B** 150 amp alternator
 - CCV-C** Closed crankcase engine ventilation
 - CCV-OX** Closed crankcase ventilation for cold markets
 - PRIM-EL** Electrical priming pump
 - PRIM-MAN** Manual priming pump
 - FUEQ-EH** Fuel line electric heater
 - AF-R** Hot fuel recirculation heated fuel filter
 - FUEFE2LW** Large engine mounted dual fuel filter with water separator
 - FUEFE2SW** Small engine mounted dual fuel filter with water separator
 - EST-AID** Air inlet manifold starting heater element
 - 220EBH15** 220V/1.5Kw electric engine block heater
 - PTER-100** Rear engine mounted power-take-off with DIN 100 / ISO 7646 flange
 - PTER-DIN** Rear engine mounted PTO with DIN5462 (female) splined shaft for a close coupled pump. Models with 3 steering axles will use this to drive the steering pump (AUXPSP)
 - PTER1400** Rear engine mounted power-take-off with SAE 1410 flange
 - HPE-F101** Parker F1-101, engine mounted, fixed displacement, single
- Standard Equipment Optional Equipment

For more detailed information about cab and powertrain equipment, please refer to separate specification sheets.

For all possible options and combinations of options please consult your Volvo sales contact who can create a specification to match your requirements using the Volvo Sales Support system (VSS).

The factory reserves the right to modify design and change equipment without previous notification. The specification can vary from country to country.

MODEL RANGE

FM 11 4x2 Tractor - X-Low - Full Air Suspension FM 42 T1XA

<input type="checkbox"/> HPE-F41	flow, engine mounted hydraulic pump Parker F1-41, engine mounted, fixed displacement, single flow, engine mounted hydraulic pump	<input type="checkbox"/> ARSL	Dynafleet or an FMS gateway has been specified with this order. Additional road speed limit - switch in dashboard
<input type="checkbox"/> HPE-F51	Parker F1-51, engine mounted, fixed displacement, single flow, engine mounted hydraulic pump	<input type="checkbox"/> CRUISE-E	Eco cruise control (with eco-roll and I-cruise, controls in steering wheel)
<input type="checkbox"/> HPE-F61	Parker F1-61, engine mounted, fixed displacement, single flow, engine mounted hydraulic pump	■ CRUISEC	Cruise control, standard
<input type="checkbox"/> HPE-F81	Parker F1-81, engine mounted, fixed displacement, single flow, engine mounted hydraulic pump	■ ESP-BAS1	Electronic Stability Control
<input type="checkbox"/> HPE-T53	Parker F2-53/53, engine mounted, Fixed displacement, Twin flow engine mounted hydraulic pump	<input type="checkbox"/> ESPC-RO	ESP (Electronic Stability Program) functionality control - Reduced / Off
<input type="checkbox"/> HPE-T70	Parker F2-70/35, engine mounted, Fixed displacement, Twin flow engine mounted hydraulic pump	<input type="checkbox"/> HWSS-ACB	Adaptive cruise control with forward collision warning and advanced emergency braking
<input type="checkbox"/> HPE-V45	Parker VP1-45, variable displacement, single flow, engine mounted hydraulic pump	■ HWSS-FCB	Forward collision warning with basic cruise control and advanced emergency brake
<input type="checkbox"/> HPE-V75	Parker VP1-75, variable displacement, single flow, engine mounted hydraulic pump	■ LSS-DW	Lane departure warning system
<input type="checkbox"/> PTR-D	Gearbox PTO for plug-in pump, 0.71xeng speed	<input type="checkbox"/> LCS	Lane change support
<input type="checkbox"/> PTR-DH	Gearbox driven high speed PTO for one plug-in hydraulic pump	<input type="checkbox"/> DAS-W	Driver Alert Support system
<input type="checkbox"/> PTR-DM	Gearbox driven medium speed PTO for one plug-in hydraulic pump	<input type="checkbox"/> RSENS-W	Rain sensing windscreen wipers
<input type="checkbox"/> PTR-F	Gearbox driven PTO with rear flange connection	<input type="checkbox"/> CU-ECC	Electrically controlled air conditioning with sun sensor
<input type="checkbox"/> PTR-FH	Gearbox driven high speed PTO with SAE drive flange	<input type="checkbox"/> CU-ECC2	Electrically controlled air conditioning with sun sensor, mist sensor, air quality sensor and carbon filter
<input type="checkbox"/> PTR-FL	Gearbox driven low speed PTO with SAE drive flange	■ CU-MCC	Climate unit with manual controlled air conditioning
<input type="checkbox"/> PTRD-D	Gearbox driven HIGH SPEED PTO for two plug-in hydraulic pumps	■ IMMOBIL	Thatcham H2 approved immobiliser
<input type="checkbox"/> PTRD-D1	PTRD-D1 Gearbox driven HIGH SPEED PTO (1 SAE flange & 1 plug-in hydraulic pump)	<input type="checkbox"/> ALARM-B	Thatcham H1 approved vehicle alarm - Cab only
<input type="checkbox"/> PTRD-D2	Gearbox driven HIGH SPEED PTO (2 SAE flanges & 1 plug-in hyd pump)	<input type="checkbox"/> ALARM-E	Enhanced vehicle alarm - Thatcham H1 approved - Cab plus external sensor for body/trailer
<input type="checkbox"/> PTRD-F	PTO with 1 DIN + 1 flange connection rear, manual gearbox	<input type="checkbox"/> ALCOLOCK	Alcolock
<input type="checkbox"/> HPG-F101	Parker F1-101 gearbox mounted, fixed displacement, single flow, hydraulic pump	<input type="checkbox"/> PHONE-PK	Telephone preparation kit (antenna, antenna attachm. cable incl.)
<input type="checkbox"/> HPG-F41	Parker F1-41 gearbox mounted, fixed displacement, single flow, hydraulic pump	<input type="checkbox"/> WLIFT-AD	Electrical window lift, automatic up/down driver side
<input type="checkbox"/> HPG-F51	Parker F1-51 gearbox mounted, fixed displacement, single flow, hydraulic pump	■ WLIFT-EB	Electrical window lift
<input type="checkbox"/> HPG-F61	Parker F1-61 gearbox mounted, fixed displacement, single flow, hydraulic pump	<input type="checkbox"/> WLIFT-ME	Mechanical window lift
<input type="checkbox"/> HPG-F81	Parker F1-81 gearbox mounted, fixed displacement, single flow, hydraulic pump	<input type="checkbox"/> ISUNS-BS	Side interior sun visor on both sides
<input type="checkbox"/> EIDLESD	Engine idle shut down	■ ISUNS-DS	Driver's side interior sun visor
<input type="checkbox"/> DTRI-PER	Dashboard in darker peregrine greyish brown. Steering wheel grey and door panels in light beige for FH and black for FH16.	■ ISUNF-B	Interior front sun visor without mirror
<input type="checkbox"/> STWPOS-L	LEFT HAND DRIVE	<input type="checkbox"/> ISUNF-MD	Interior front sun visor with mirror on driver side
■ STWPOS-R	RIGHT HAND DRIVE	<input type="checkbox"/> ISUNF-RE	Electrically operated textile interior sun blind
<input type="checkbox"/> STWM-LE	Leather steering wheel	<input type="checkbox"/> ISUNF-RM	Manually operated textile interior sun blind
<input type="checkbox"/> STGW-AD2	Adjustable steering wheel with neck tilt	<input type="checkbox"/> ADFS	Two extra DIN slots in front shelf - can be fitted with card or drawer available as an accessory
■ STGW-ADJ	Adjustable steering wheel	■ BUPALARM	Reverse alarm
■ AIRBAG	SRS Driver's air bag	<input type="checkbox"/> BUPMON	Back up monitor with built in 7" screen on dash and one colour camera supplied loose for fitment by bodybuilder.
■ DRC-AMII	DPF Regeneration control switch - for manual and switching off regeneration	<input type="checkbox"/> RTOLL-PK	Road toll PREPARATION kit for trucks operating with "Toll Collect" in Germany
<input type="checkbox"/> 1DAYDIG	Continental VDO DTCO 3.0 digital tachograph This tachograph can ONLY offer remote download if the option of Dynafleet or an FMS gateway has been specified with this order.	<input type="checkbox"/> LOADIND	Load indicator with central dashboard display
■ 1DAYDIG2	Continental VDO DTCO 4.0 smart tachograph This tachograph can ONLY offer remote download if the option of Dynafleet or an FMS gateway has been specified with this order.	<input type="checkbox"/> REMC-MF	Multi-functio wireless remote control
<input type="checkbox"/> 1DAYDIGP	Continental VDO DTCO 3.0 digital tachograph For vehicles with long lead time - this includes prep kit for the retrofit of DTCO 4.0 tachograph. For updating to new legal demand for trick registration from 15th June 2019. This tachograph can ONLY offer remote download if the option of	<input type="checkbox"/> FIREXT3S	3kg fire extinguisher mounted on seat base
		<input type="checkbox"/> WARNVEST	High visibility warning vest - no sleeves
		<input type="checkbox"/> AIDKIT	First aid kit
		■ AIDKIT1B	First aid kit
		<input type="checkbox"/> WARNLAMP	Portable warning lamp
		<input type="checkbox"/> LAMP-IN	Inspection lamp
		<input type="checkbox"/> BULBKIT	Bulb and fuse kit
		<input type="checkbox"/> WRITEPAD	Writing pad
		<input type="checkbox"/> UPHTRI10	Seats: Black embossed textile insert with light grey sides, black vinyl side bolster with blue vinyl side insert. Interior trim: Raven black bunk and curtains & blue textile side
■ Standard Equipment	<input type="checkbox"/> Optional Equipment		

For more detailed information about cab and powertrain equipment, please refer to separate specification sheets.

For all possible options and combinations of options please consult your Volvo sales contact who can create a specification to match your requirements using the Volvo Sales Support system (VSS).

The factory reserves the right to modify design and change equipment without previous notification. The specification can vary from country to country.

MODEL RANGE

FM 11 4x2 Tractor - X-Low - Full Air Suspension FM 42 T1XA

- | | |
|---|---|
| <ul style="list-style-type: none"> <input type="checkbox"/> UPHTRI11 walls
Seats: Light grey embossed textile insert, black raven metallic vinyl bolster with red vinyl side insert.
Interior trim: Raven black bunk and curtains & grey vinyl side walls <input type="checkbox"/> UPHTRI12 Seats: Blue soft textile insert, black vinyl bolster.
Interior trim: Raven black bunk and curtains & blue textile side walls <input type="checkbox"/> UPHTRI13 Seats: Dark grey leather insert and black leather bolster.
Interior trim: Raven black bunk and curtains & grey vinyl side walls <input type="checkbox"/> UPHTRI14 Seat: Dark grey leather insert and black leather bolster.
Interior trim: Raven black bunk and curtains & blue textile side walls ■ DST-CF4 Driver seat, comfort, suspended, belt in seat <input type="checkbox"/> DST-CF5 Driver seat, comfort, suspended, belt in seat, electrically heated <input type="checkbox"/> DST-CF6 Driver seat, comfort, suspended, belt in seat, electrically heated, ventilated <input type="checkbox"/> SBD-RED Red seat belts <input type="checkbox"/> SBPRE-DS Driver seat belt pretensioner ■ PST-BAS1 Passenger seat - Fixed non suspended fold up with seatbelt mounted in cab <input type="checkbox"/> PST-BENC Bench passenger seat <input type="checkbox"/> PST-CF4 Passenger seat - Comfort suspended with seatbelt mounted in seat <input type="checkbox"/> PST-CF5 Passenger seat - Comfort suspended & heated with seatbelt mounted in seat <input type="checkbox"/> PST-STD2 Passenger seat - Fixed non suspended with seatbelt mounted in cab <input type="checkbox"/> PST-STD4 Passenger seat - Standard suspended with seatbelt mounted in cab <input type="checkbox"/> SBPRE-PS Passenger seat belt pretensioner <input type="checkbox"/> ARM-DBPS Two armrests on driver seat and one (outer) on passenger seat <input type="checkbox"/> ARMRE-BB Two armrests on both driver and passenger seat. <input type="checkbox"/> ARMRE-DB Two armrests, on driver seat only <input type="checkbox"/> ARMRE-PB Two armrests, on passenger seat only <input type="checkbox"/> ARMRE-PS Single armrest (next to driver) on passenger seat <input type="checkbox"/> ARU-BAS Vinyl upholstered armrest <input type="checkbox"/> ARU-LEA Leather upholstered armrest ■ FMAT-RUB Rubber floor mats <input type="checkbox"/> FMAT-TX2 Textile and rubber floor mats <input type="checkbox"/> LBK-RES Foldable rest bunk ■ LBK70 Lower bunk 700 x2000 mm, fixed <input type="checkbox"/> ULBK Without lower bunk <input type="checkbox"/> MATL-FI Firm lower bunk pocket sprung mattress ■ MATL-SF Lower flexizone mattress - semi-firm, pocket springs up to 100kg - 16 stone <input type="checkbox"/> MATL-SO Lower flexizone mattress - soft, pocket springs up to 85kg - 13.5 stone <input type="checkbox"/> OLMAT-BA 35mm mattress overlay protector <input type="checkbox"/> OLMAT-PR 50mm premium mattress overlay protector <input type="checkbox"/> TBK60F Fixed foldable top bunk 600 x 1900mm <input type="checkbox"/> TBK70F Fixed foldable top bunk 700 x 1900mm <input type="checkbox"/> PH-CAB2 1.8kW Air to air night heater <input type="checkbox"/> PH-ENGCA Engine and cab night heater <input type="checkbox"/> PH-SS Short stop heater <input type="checkbox"/> SLCP-BAS Basic sleeper control panel - includes interior light, parking heater, roof hatch and door lock <input type="checkbox"/> SAFE Safe box for driver's personal items <input type="checkbox"/> ETSB-F Storage on engine tunnel - on front top <input type="checkbox"/> ETSB-FR Storage on engine tunnel - on front top and at rear cab wall <input type="checkbox"/> ETSB-FRS Storage on engine tunnel - on front top & at rear cab wall & storage recessed into tunnel on right hand side <input type="checkbox"/> ETSB-FS Storage on engine tunnel - on front top and storage recessed | <ul style="list-style-type: none"> <input type="checkbox"/> ETSB-R into tunnel on right hand side <input type="checkbox"/> ETSB-R Storage on engine tunnel - box at rear cab wall <input type="checkbox"/> ETSB-S Storage on engine tunnel - at rear cab wall and storage recessed into tunnel on right hand side <input type="checkbox"/> ETSB-S Storage on engine tunnel - recessed into tunnel on right hand side <input type="checkbox"/> RUS-BAS Rear cab upper storage 154 litres - 300 mm high <input type="checkbox"/> RUS-HIG Rear cab upper storage 245 litres - 440 mm high <input type="checkbox"/> TABLE Folding and height adjustable table - on lower bunk <input type="checkbox"/> REF-ICPK Refrigerator preparation kit, engine tunnel mounted <input type="checkbox"/> REFR-RUS 28 litre rear upper wall mounted refrigerator with dividers <input type="checkbox"/> BOTH-D One bottle holder under dashboard centre section <input type="checkbox"/> COFMA-PK Coffee maker, preparation kit. ■ INLI-BAS Basic white interior lights <input type="checkbox"/> INLI-NL Interior white and red night light with no dimmer <input type="checkbox"/> INLI-NLD Interior white and red night light with dimmer function <input type="checkbox"/> ARL-FLEX Two flexible reading lamps (snake lamps) <input type="checkbox"/> RH-ECS Glass roof hatch - Electrically operated <input type="checkbox"/> RH-EE Without roof hatch <input type="checkbox"/> RH-ETR Roof & escape hatch - Electrically operated, tinted glass with rear opening <input type="checkbox"/> RH-MSR Steel roof hatch - Manually operated with rear opening <input type="checkbox"/> RH-MTR Roof & escape hatch - Manually operated, tinted glass with rear opening ■ URH Without roof hatch <input type="checkbox"/> SWIND-BS Extra side window on both sides behind "B" pillar <input type="checkbox"/> SWIND-PS Rear side window, passenger side <input type="checkbox"/> VANMIR Vanity mirror in front shelf <input type="checkbox"/> AS-FUS Extra shelf in front upper storage compartments <input type="checkbox"/> INFOT-PK Preparation kit for the mounting of a flat screen TV in cab above the driver's door, includes bracket, electrical and speaker connections |
|---|---|

CAB EXTERIOR

- PAICS-B** Basic cab paint - mirrors, sunvisor, instep and bumper supplied in natural finish - grey
- PAICS-C** Complete cab - mirrors, insteps, sunvisor, and bumper finished in cab colour
- **GLAS-TIN** Tinted windows.
- AWIND-RF** Rear window
- DGLAS-L** Laminated door glass
- **LOCK-MAN** Manual door locking
- LOCK-MRP** Manual door locking with internal remote control (from driver side) of passenger door
- LOCK-REM** Central locking with remote control
- **BUMP-B** Plastic front bumper
- BUMP-B2** Steel front bumper
- **BUGNET** Insect screen in front of radiator
- CTILT-P-E** Electrically operated hydraulic cab tilt
- **CTILT-P-M** Manually operated hydraulic cab tilt
- FCABS-A** Front cab - Air suspension
- **FCABS-M** Front cab - Mechanical spring suspension
- RCABS-A** Rear cab suspension - Air
- **RCABS-M** Rear cab suspension - Mechanical spring
- MIRCOMF2** Basic electrically heated and operated mirrors FMX style with wide angle and passenger kerb mirror, to increase vision side mirrors have no mirror cowlings.
- MIRCOMFM** Electrically heated and operated main mirror with heated wide angle mirror on both sides, manual kerb view mirror on passenger side
- MIRSTD2** Basic electrically heated FMX style main with wide angle and passenger kerb mirror, to increase vision side mirrors have no

■ Standard Equipment □ Optional Equipment

For more detailed information about cab and powertrain equipment, please refer to separate specification sheets.

For all possible options and combinations of options please consult your Volvo sales contact who can create a specification to match your requirements using the Volvo Sales Support system (VSS).

The factory reserves the right to modify design and change equipment without previous notification. The specification can vary from country to country.

MODEL RANGE

FM 11 4x2 Tractor - X-Low - Full Air Suspension FM 42 T1XA

- **MIRSTDFM** mirror cowlings.
Electrically heated exterior mirrors with wide angle mirror on both sides and kerb view mirror on passenger side
 - **AMIR-F20** Auxiliary front view mirror with a 200mm radius
 - **SUNV-H** External smoke grey sunvisor
 - **AD-ROOF** Roof air deflector
 - **AD-SIDEL** Side air deflector extension panels
 - **AD-SIDES** Short cab side air deflector for rigid bodywork
 - **HL-BASIC** Halogen H7 head lamps
 - **HL-BHID** High intensity Bi-Xenon head lamps
 - **HL-DBL** Bi-Xenon high intensity discharge and dynamic head lamps. Dipped beam follows the road, activated by a signal from the steering system.
 - **HL-CLEAN** Head lamp cleaner - washer jets
 - **HLP-ST** Headlamp protection
 - **HL-ADJ** Adjustable headlights with switch in the cab
 - **DRIVL2** Two spot lamps
 - **UDRIVL** Without auxiliary driving lights
 - **FOGL-WC** Front fog lights
 - **CL-STAT** Static corner lights
 - **ASL-RF2** Two Hella H11 70W spotlamps in sign box - only available with the basic headlight and no lower driving lights.
 - **ASL-RFPK** Preparation kit for two spotlamps in sign box
 - **BEACOA2F** Two front roof mounted amber beacon rotating warning lamps
 - **BEACOA2R** Two rear roof mounted (on accessory bracket) amber beacon flashing warning LED lamps
 - **BEACON-P** Roof beacon wire preparation
 - **BEACONA4** Four roof mounted (2 front/2 rear) amber beacon rotating warning lamps
 - **CABPT-R1** Single outlet for roof mounted accessories
 - **CABPT-R2** Twin outlets for roof mounted accessories.
 - **SPOTP-F** Spotlamp preparation in front, max 280W
 - **SPOTP-R** Spotlamp preparation on roof, max 280W
 - **SPOTP-RF** Spotlamp preparation on cab roof and in cab front, max 2x280W
 - **CSGN-GTR** "Globetrotter" headboard logo
 - **HORN-F1S** Single tone Jericho air horn chassis mounted
 - **HORN-R2S** Two roof mounted air horns
 - **ANT-CBR** Roof mounted antenna for CB radio, single aerial
 - **ACCBR-AP** Front, middle & rear roof mounted accessory brackets
 - **ACCBR-F** Front roof mounted accessory bracket
 - **ACCBR-FM** Front & middle roof mounted accessory brackets
 - **ACCBR-FR** Front & rear roof mounted accessory brackets
 - **ACCBR-M** Middle roof mounted accessory bracket
 - **ACCBR-R** Rear roof mounted accessory bracket
 - **ACCBR-RM** Rear & middle roof mounted accessory brackets
 - **RFCAR-BC** Rear mudwing carrier, back of cab
 - **LADDER** Ladder back of cab
 - **REFS-TW** White cab conspicuity markings by packed in cab
 - **REFS-TY** Yellow cab conspicuity markings by packed in cab
- SUPERSTRUCTURE PREPARATIONS**
- **5WM-ASM** 50mm high 'L' profiles for air actuated sliding 5th wheel
 - **5WM-DH** Dual height 5th wheel mounting
 - **5WM-ISOL** 5th wheel subframe 16mm high above chassis frame
 - **5WM-ISOM** 5th wheel subframe 60mm high above chassis frame
 - **5WM-LPRO** 5th wheel attached direct to frame with inverted 'L'-profiles
 - **5WM-MASL** 4mm high 'L' profiles for manual sliding fifth wheel
 - **5WM-MASM** 50mm high 'L' profiles for manual sliding fifth wheel
 - **5WH140** Fifth wheel leg-height 140 mm
 - **5WH150** Fifth wheel leg-height 150 mm
 - **5WH160** Fifth wheel leg-height 160 mm
 - **5WH175** Fifth wheel leg height 175mm
 - **5WH17D37** Fifth wheel leg-height 167 mm to 367mm
 - **5WH185** Fifth wheel leg-height 185 mm
 - **5WH195** Fifth wheel leg-height 195mm
 - **5WH200** Fifth wheel leg-height 200 mm
 - **5WH205** Fifth wheel leg-height 205 mm
 - **5WH210** Fifth wheel leg-height 210 mm
 - **5WH220** Fifth wheel leg-height 220mm
 - **5WH230** Fifth wheel leg-height 230 mm
 - **5WT-FO14** Fontaine 150SP2 pressed steel fifth wheel
 - **5WT-FO15** Fontaine 3000 lightweight cast fifth wheel with 150SF air operated slider - for moderate duty off road. Specified fifth wheel position always gives rearmost position.
 - **5WT-JO10** Jost JSK 36 pressed fifth wheel
 - **5WT-JO8** Jost JSK 37 cast fifth wheel
 - **5WT-JO9** Jost JSK 42 cast fixed fifth wheel
 - **5WT-SH** SAF-Holland/+GF+ SK-S 36.20 cast fixed fifth wheel
 - **5WLM-B** Basic fifth wheel maintenance standard top plate
 - **5WLM-L** Low maintenance fifthwheel with nylon top plate
 - **5WL-S1** Fifth wheel lubrication - locking mechanism and top plate
 - **5WL-S2** Fifth wheel lubrication - locking mechanism
 - **TCIND** Trailer connection indication with sensors for height, kingpin and coupling lock
 - **RDECK** Catwalk & step
 - **RDECK-M** Rear catwalk 760mm
 - **SRWL-PK** Wiring preparation for side & rear work/reverse lamps on side of chassis and a three-position switch, maximum 280W
 - **SWL-2RA** Two H3 35W amber rear chassis mounted (LH/RH side) working lamps and a 2-position switch (On/Off)
 - **SWL-2RW** Two H3 70W white rear chassis mounted (LH/RH side) working lamps and a 2-position switch (On/Off)
 - **SWL-PK** Wiring preparation for side work/reverse lamps on side of chassis and a three-position switch, maximum 280W
 - **WL-TA1W** White coupling light
 - **WLC-H2A** Two H3/70W working lamps with amber coloured lens high mounted back of cab
 - **WLC-H2W** Two H3/70W white working lamps high mounted on the back of cab
 - **WLC-PKH** Preparation kit, cables and switch for high mounted working lamps back of cab
 - **WLC-PKL** Preparation kit, cables and switch for low mounted working lamps back of cab
 - **WLC-PKLH** Preparation kit - cables and switch for low and high mounted working lamps back of cab.
 - **ECBB-BAS** Body builder electrical centre without body builder module
 - **ECBB-HIG** Body builder electrical centre with body builder module
 - **BBCHAS1** One 7-pole connector for Body builder interface
 - **BBCHAS3** Three 7-pole connectors for Body builder interface
 - **BEPR-T2** Body builder electrical software preparation for tipper with remote control
 - **EXSTER** External steering control, with VDS and bodybuilder module
 - **TD-BAS** Trailer detection WITHOUT LED sensing
 - **TD-LED** Trailer detection with LED sensing
 - **AUXL-SPK** Electrical preparation kit - wiring and switch for snow plough lights
 - **TAILPRE2** Tail lift preparation kit, wireless remote operation
 - **TAILPREP** Taillift preparation kit - cab switch and warning in driver display
 - **AESW2** Two Body builder bistable electrical switches (marked AUX1 / AUX2)
 - **AESW2PK** 2 Body builder bistable el.switches (marked AUX1/AUX2) and prep. for 4 more switches
 - **AUXSW-4** Wiring for 4 extra switches (from Body builder electrical centre to switch positions)

■ Standard Equipment □ Optional Equipment

For more detailed information about cab and powertrain equipment, please refer to separate specification sheets.

For all possible options and combinations of options please consult your Volvo sales contact who can create a specification to match your requirements using the Volvo Sales Support system (VSS).

The factory reserves the right to modify design and change equipment without previous notification. The specification can vary from country to country.

MODEL RANGE

FM 11 4x2 Tractor - X-Low - Full Air Suspension FM 42 T1XA

DELIVERY SERVICES

- **TGW-3GWL** Telematics gateway with GSM/GPRS/3G modem and wireless lan WLAN
- **FMS-PK** Fleet Management System gateway
- **DRUT** "My Truck App" Two years subscription to driver utility application

VOLVO

Volvo Truck Corporation
volvotrucks.com