

MODEL RANGE

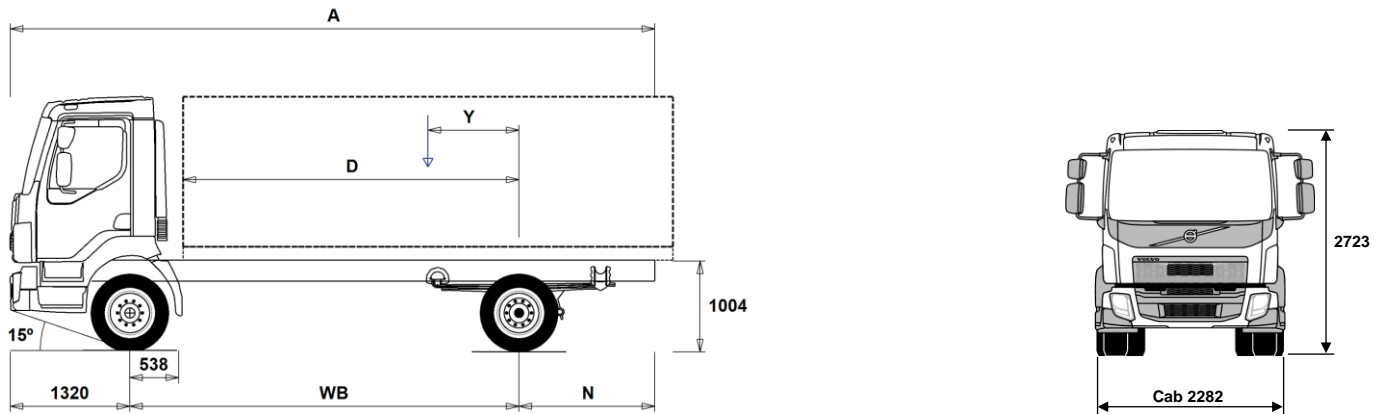

Volvo Trucks. Driving Progress

FL812 4x2 Rigid 12 tonne - Steel Suspension FL 42 R 812L



Chassis Dimensions [mm]

WB Wheelbase	3250	3500	3800	4100	4400	4700	5000	5300	5600	5900	6200	6500
A Overall Chassis Length	6545	6975	7425	7955	8425	8915	9435	9915	10425	10835	11430	11730
D Center of rear axle to front of body	2662	2912	3212	3512	3812	4112	4412	4712	5012	5312	5612	5912
N Rear Overhang (Min.)	1515	1685	1615	1515	1615	1615	1615	1615	1615	1615	1615	1615
N Rear Overhang (Max.)	1975	2155	2305	2535	2705	2895	3115	3295	3505	3615	3910	3910
Y Center of Gravity for Payload (Min.)	163	176	189	207	223	237	252	262	276	287	302	305
Y Center of Gravity for Payload (Max.)	589	636	692	750	807	863	920	974	1030	1083	1141	1189

Chassis Weights [kg]

Front Axle	3115	3120	3125	3120	3120	3120	3120	3130	3135	3140	3140	3155
Rear Axle	1255	1280	1310	1330	1350	1370	1390	1420	1435	1450	1470	1490
Kerb Weight	4370	4400	4435	4450	4470	4490	4510	4550	4570	4590	4610	4645
Payload (including body, driver, fuel, etc.)	7630	7600	7565	7550	7530	7510	7490	7450	7430	7410	7390	7355

Turning Diameter [mm]

Turning Circle Diameter Kerb to Kerb	11600	12400	13300	14200	15100	16000	16900	17800	18700	19600	20500	21400
Turning Circle Diameter Wall to Wall	12900	13700	14600	15500	16400	17300	18200	19100	20000	20900	21800	22700

Plated Weights [kg]

	Plated	Design
Gross Vehicle Weight	12000	12000
Gross Combination Weight	15500	15500
Front Axle	4500	4500
Rear Axle	8500	8500

Important Notes

Chassis Dimensions

Cab Height: +39 mm for CAB-CRW.
 Front Axle to Back of Cab: +1302 mm for CAB-CRW, +294 mm for CAB-SSLP.
 D-measure includes a front clearance of 50 mm and for rigid trucks also a subframe of 120 mm.
 Height can vary ± 20 mm for leaf and ± 10 mm for air suspension.
 All dimensions are for unladen chassis and any tag axles down. Chassis height used: CHH-MED.

Weight and dimensions are based upon the following tyres:
 Front Axle Tyres: 265/70R19.5
 Drive Axle Tyres: 265/70R19.5

Chassis weight includes oil, water, AdBlue, 0 litres fuel and without driver. Kerb weight can vary $\pm 3\%$.

Turning diameters are theoretically calculated.

Legal weights can differ from country to country.

For more detailed weight information, including optional equipment weights, ask your Volvo sales contact to enter your specification into the Volvo Weight Information system (WIS).

Do NOT use this drawing for bodybuilding. Refer to Volvo Bodybuilder Instructions and chassis assembly drawing FL42R812L.

MODEL RANGE

FL812 4x2 Rigid 12 tonne - Steel Suspension FL 42 R 812L

CORE COMPONENTS

- CHH-HIGH** Chassis height high - N3 "On Road" chassis - For a specific loading height always check the unique BEP chassis drawing
- CHH-MED** Chassis height medium - For a specific loading height always check the unique BEP chassis drawing
- RAD-L80** 80mm parabolic rear springs
- EU6SCR** Emission level - Euro 6
- D8K250** D8K250 six cylinder 7.7 litre engine developing 250hp at 2100rpm.
Peak torque 950Nm at 900-1700rpm.
- D8K280** D8K280 six cylinder 7.7 litre engine developing 280hp at 2100rpm.
Peak torque 1050Nm at 950-1700rpm.
- EBR-CEB** Exhaust brake producing 170kW at 2800rpm controlled by steering column switch
- EBR-EPG** Exhaust brake producing 120kW at 2800rpm controlled by steering column switch
- AL306** Allison AL306 6-speed automatic gearbox (If a PTO is required it must be specified from the factory)
- ATO1056** 6-speed overdrive "I Sync" automated mechanical gearbox
- ZTO1006** 6-speed overdrive gearbox
- RSS1125A** RS1125A single reduction rear axle - design GCW 25tonne with differential lock
- RSS1132A** RS1132A single reduction rear axle - design GCW 32tonne with differential lock

Packages

- DRIVEFL** NEW drive package FL
- VISIFL** NEW visibility package FL
- AIRFLOW** NEW airflow package
- AUDIOBAS** AM/FM Radio with Bluetooth and optional DAB signal - without CD player
- AUDIOPK** Audio preparation

CHASSIS

- FST-PAR** Parabolic front springs with shock absorbers and anti roll bar
- FST-PAR3** Stiff parabolic front springs with shock absorbers and anti roll bar
- FAL4.5** Front axle design capacity 4.5 tonnes
- FAL5.0** Front axle design capacity 5.0 tonnes
- RAL8.5** Rear axle design capacity 8.5 tonnes
- RAL9.2** Rear axle design capacity 9.2 tonnes
- RSTAB1** Rear anti-roll bar
- EBS-MED** EBS+ package including traction control & hill hold
- EBS-STD** EBS standard package without traction control
- RST-PAR1** Parabolic rear springs
- RST-PAR3** Stiffer parabolic rear springs
- FST5050** Frame thickness 5mm
- FST6060** Frame thickness 6mm
- FST7070** Frame thickness 7mm
- FST8080** Frame thickness 8mm
- 2BATT170** 2 x 170 Ah capacity batteries on left hand side
- BAMAFREE** Maintenance free batteries
- ADR2** ADR package for transportation of dangerous goods on road (Note does NOT include safe loading pass package if required this is quoted separately)
- R215P** 215 litre right hand plastic fuel tank
Min volume 80l
Max volume 430l
- UL-FUEL** Without left fuel tank
Min volume 80l
Max volume 215l

Standard Equipment

Optional Equipment

For more detailed information about cab and powertrain equipment, please refer to separate specification sheets.

For all possible options and combinations of options please consult your Volvo sales contact who can create a specification to match your requirements using the Volvo Sales Support system (VSS).

The factory reserves the right to modify design and change equipment without previous notification. The specification can vary from country to country.

- ADTP-L** AdBlue tank on left hand side
- ADTP-R** AdBlue tank on right hand side
- WHC-FIX1** One wheel chock
- WHC-FIX2** Two wheel chocks
- TOWMBRH** Towing member, high position, mounted in centre of frame
- C-RO40AG** Rockinger 400 G145
- TOWF-NO1** One towing device in front.
- TOWF-NO2** Two towing devices in front.
- TOWR-ONE** Pintle type towing hitch attached to rear crossmember for 3.5tonne trailer
- TREL15** Single 15 pole electrical trailer connector - ADR certified
- TBC-EC**
- RUP-FIX2** Fixed rear EC approved aluminium underrun
- RFEND-T** Mudwings on drive axle for transportation only

WHEELS & TYRES

- SPWT-F** Spare wheel & tyre with front tyre pattern
- SWCP-LF** Spare wheel carrier on left side of chassis ahead of rear axle
- SWCP-R** Spare wheel carrier rear mounted below frame.
- SWCP-T** Spare wheel supplied temporarily strapped to chassis
- SWCP-TP** Spare wheel carrier transport mounted on frame (spare wheel carrier not included)
- JACK-10T** 10 tonne bottle jack
- JACK-8T** 8 tonne bottle jack
- GAUGE-TP** Tyre pressure gauge

DRIVELINE EQUIPMENT

- CS39A-O** Single plate 395mm (16") clutch
- RET-TPT** Retarder for automatic gearbox
- TC-HWO** Automatic gearbox oil cooler - water to oil
- 1COMP500** Single cylinder air compressor 360 cc / 500 l/min
- 2COM1080** Two cylinder, air compressor, 1080 litres per minute
- AIRIN-HI** High air intake behind cab on left hand side
- AIRIN-RL** Chassis mounted mounted behind cab on right hand side
- ACL1ST** Air cleaner with one filter element
- ACL1ST-S** Air filter with secondary filter element
- 24AL110B** 110 amp alternator
- 24AL130B** 130 amp alternator
- CCV-C** Closed crankcase ventilation
- CCV-OX** Open crankcase ventilation with oil separator and a maintenance free gas centrifuge
- EST-AID** Air inlet manifold starting heater element
- PTER-100** Rear engine mounted power-take-off with DIN 7476 flange
- PTER-DIN** Rear engine mounted PTO with DIN5462 (female) splined shaft for a close coupled pump
- PTER1400** Rear engine mounted power-take-off with SAE 1410 flange
- PR-HF4S** Live-drive PTO for Allison gearbox output 400Nm for flange connection
mounted on the side of the torque convertor
- PR-HF4SH** Live-drive high speed PTO for Allison gearbox output 400Nm for hydraulic pump connection
mounted on the side of the torque convertor
- PR-HF6S** Live-drive PTO for Allison gearbox output 600Nm for flange connection
mounted on the side of the torque convertor
- PR-HP4S** Live-drive PTO for Allison gearbox output 400Nm for hydraulic pump connection
mounted on the side of the torque convertor
- PR-HP4SH** Live-drive high speed PTO for Allison gearbox output 400Nm for hydraulic pump connection
mounted on the side of the torque convertor
- PR-HP6S** Live-drive PTO for Allison gearbox output 600Nm for hydraulic

MODEL RANGE

FL812 4x2 Rigid 12 tonne - Steel Suspension FL 42 R 812L

- PTR-FH1 pump connection mounted on the side of the torque convertor
- PTR-FH2 Rear PTO Gearbox S81 flange DIN connection
- PTR-FH5 Rear PTO Gearbox S84 flange DIN connection
- PTR-FH5 Rear PTO Gearbox S88 flange DIN connection
- PTR-PH1 Rear PTO Gearbox S81 pump DIN connection
- PTR-PH2 Rear PTO Gearbox S84 pump DIN connection
- PTR-PH4 Rear PTO Gearbox S88 pump DIN connection
- PTR-PK Electrical and solenoid prep kit for gearbox PTO
- PTR-ZF2 Rear Power Take Off flange DIN connection
- PTR-ZF3 Rear Power Take Off Gearbox pump DIN connection
- PTR-ZF4 Rear PTO Gearbox 320Nm flange connection
- PTR-ZF5 Rear PTO Gearbox 320Nm pump connection
- PTR-ZF6 Rear PTO Gearbox 320Nm flange connection

- HPG-F101 Gearbox mounted hydraulic pump F1-101, fixed displacement, single flow.
- HPG-F41 Gearbox mounted hydraulic pump F1-41, fixed displacement, single flow.
- HPG-F51 Gearbox mounted hydraulic pump F1-51, fixed displacement, single flow.
- HPG-F61 Gearbox mounted hydraulic pump F1-61, fixed displacement, single flow.
- HPG-F81 Gearbox mounted hydraulic pump F1-81, fixed displacement, single flow.

- ETC Electronic throttle control - dash mounted switch for PTO speed control

CAB INTERIOR

- STWPOS-R RIGHT HAND DRIVE

CAB EXTERIOR

- SUNV-B Exterior sun visor - smoked grey
- SUNV-PK Sunvisor installation preparation kit

- AD-ROOF Fixed cab roof air deflector - not adjustable

- AD-SIDES Cab side air deflector, short extension panels.

- BEACON-P Beacon preparation
- BEACONA2 Two amber beacons directly mounted to cab roof

SUPERSTRUCTURE PREPARATIONS

- FBA-BTF Lower front body attachments for torsionally flexible - platform body
- FBA-BTSF Lower front body attachments for torsionally semi-flexible body - box or curtainsider

- RBA-T2 Rear body attachments, divided

- TAILPREP Taillift preparation kit - cab switch and warning in driver display

DELIVERY SERVICES

- WVTA Whole Vehicle Type Approved - MANDATORY for standard truck

VOLVO

Volvo Truck Corporation
volvotrucks.com