

MODEL RANGE

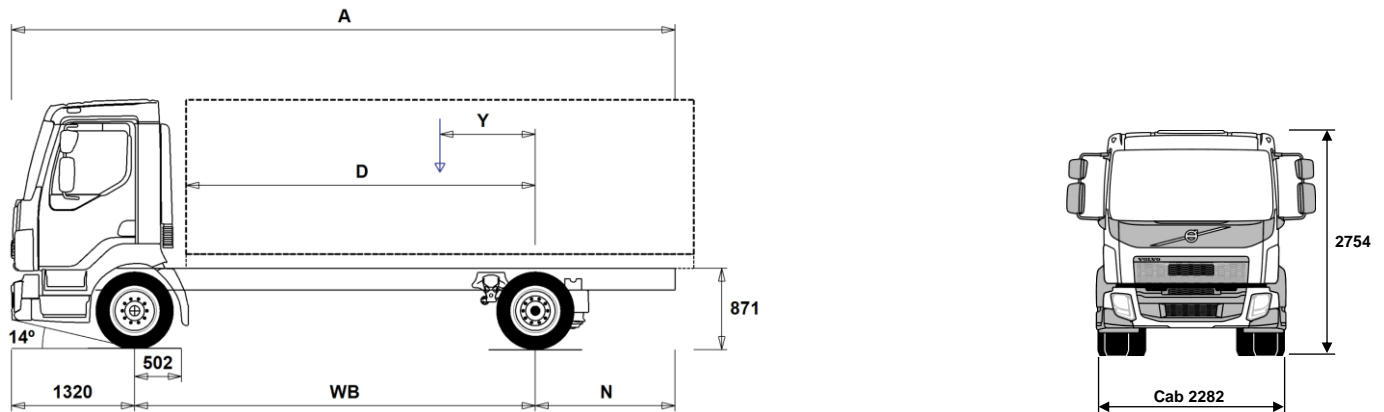

Volvo Trucks. Driving Progress

FL516 4x2 Platform 16 tonne - Rear Air Suspension FL 42 R 516A



Chassis Dimensions [mm]

WB Wheelbase	3500	3800	4100	4400	4700	5000	5300	5600	5900	6200	6500
A Overall Chassis Length	6975	7425	7955	8425	8915	9435	9915	10425	10835	11430	11730
D Center of rear axle to front of body	2948	3248	3548	3848	4148	4448	4748	5048	5348	5648	5948
N Rear Overhang (Min.)	2055	1885	2445	2635	2835	2895	2895	3415	3295	3505	3755
N Rear Overhang (Max.)	2155	2305	2535	2705	2895	3115	3295	3505	3615	3910	3910
Y Center of Gravity for Payload (Min.)	595	646	700	752	803	853	904	956	1002	1056	1101
Y Center of Gravity for Payload (Max.)	595	646	700	752	803	853	904	956	1002	1056	1101

Chassis Weights [kg]

Front Axle	2970	2975	2975	2975	2980	2990	2995	2995	3010	3015	3025
Rear Axle	1355	1380	1400	1415	1440	1475	1495	1515	1545	1570	1580
Kerb Weight	4325	4355	4375	4390	4420	4465	4490	4510	4555	4585	4605
Payload (including body, driver, fuel, etc.)	8875	8845	8825	8810	8780	8735	8710	8690	8645	8615	8595

Turning Diameter [mm]

Turning Circle Diameter Kerb to Kerb	12400	13300	14200	15100	16000	16900	17700	18600	19500	20400	21300
Turning Circle Diameter Wall to Wall	13700	14600	15500	16400	17300	18200	19100	20000	20900	21800	22700

Plated Weights [kg]

	Plated	Design
Gross Vehicle Weight	13200	16000
Gross Combination Weight	21000	21000
Front Axle	4480	5800
Rear Axle	8720	10900

Important Notes

Chassis Dimensions

Cab Height: +39 mm for CAB-CRW.
 Front Axle to Back of Cab: +1338 mm for CAB-CRW, +330 mm for CAB-SSLP.
 D-measure includes a front clearance of 50 mm and for rigid trucks also a subframe of 120 mm.
 Height can vary ± 20 mm for leaf and ± 10 mm for air suspension.
 All dimensions are for unladen chassis and any tag axles down.

Weight and dimensions are based upon the following tyres:
 Front Axle Tyres: 245/70R19.5
 Drive Axle Tyres: 245/70R19.5

Chassis weight includes oil, water, AdBlue, 0 litres fuel and without driver. Kerb weight can vary $\pm 3\%$.

Turning diameters are theoretically calculated.

Legal weights can differ from country to country.

For more detailed weight information, including optional equipment weights, ask your Volvo sales contact to enter your specification into the Volvo Weight Information system (WIS).

Do NOT use this drawing for bodybuilding. Refer to Volvo Bodybuilder Instructions and chassis assembly drawing FL42R516A.

MODEL RANGE

FL516 4x2 Platform 16 tonne - Rear Air Suspension FL 42 R 516A

CORE COMPONENTS

- **CHH-MED** Chassis height medium - For a specific loading height always check the unique BEP chassis drawing
- **RAD-A2V** Two bag rear air suspension
- **EU6SCR** Emission level - Euro 6
- **D5K210** D5K210 four cylinder 5.1 litre engine developing 210hp at 2200rpm.
Peak torque 800Nm at 1100-1700rpm.
- **D5K240** D5K240 four cylinder 5.1 litre engine developing 240hp at 2200rpm.
Peak torque 900Nm at 1100-1600rpm.
- **EBR-EPG** Exhaust brake producing 120kW at 2800rpm controlled by steering column switch
- **ATO1056** 6-speed overdrive "I Sync" automated mechanical gearbox
- **ATO8006** 6-speed overdrive "I Sync" automated mechanical gearbox
- **STO8006** 6 speed overdrive gearbox, 850 Nm
- **ZTO1006** 6-speed overdrive gearbox
- **RSS1125A** RS1125A single reduction rear axle - design GCW 25tonne with differential lock
- **RSS1132A** RS1132A single reduction rear axle - design GCW 32tonne with differential lock

Packages

- **DRIVEFL** NEW drive package FL
- **VISIFL** NEW visibility package FL
- **AIRFLOW** NEW airflow package
- **AUDIOBAS** AM/FM Radio with Bluetooth and optional DAB signal - without CD player
- **AUDIOPK** Audio preparation

CHASSIS

- **FST-PAR** Parabolic front springs with shock absorbers and anti roll bar
- **FAL5.8** Front axle design capacity 5.8 tonnes
- **RAL10.9** Rear axle design capacity 10.9 tonnes
- **EBS-MED** EBS+ package including traction control & hill hold
- **EBS-STD** EBS standard package without traction control
- **RST-AIR** Rear air suspension
- **SUSPL-E1** Remote control on wander-lead for air suspension leveling
- **SUSPL-E2** Integral dash switches for air suspension leveling control
- **SUSPL-E3** Remote control on wander-lead for air suspension leveling
- **FST7070** Frame thickness 7mm
- **FST8080** Frame thickness 8mm
- **2BATT170** 2 x 170 Ah capacity batteries on left hand side
- **BAMAFREE** Maintenance free batteries
- **ADR2** ADR package for transportation of dangerous goods on road (Note does NOT include safe loading pass package if required this is quoted seperately)
- **R215P** 215 litre right hand plastic fuel tank
Min volume 80l
Max volume 430l
- **UL-FUEL** Without left fuel tank
Min volume 80l
Max volume 215l
- **ADTP-L** AdBlue tank on left hand side
- **ADTP-R** AdBlue tank on right hand side
- **WHC-FIX1** One wheel chock
- **WHC-FIX2** Two wheel chocks
- **TOWMBRH** Towing member, high position, mounted in centre of frame
- **C-RO40AG** Rockinger 400 G145
- **TOWF-NO1** One towing device in front.

- **TOWF-NO2** Two towing devices in front.
- **TOWR-ONE** Pintle type towing hitch attached to rear crossmember for 3.5tonne trailer
- **TREL15** Single 15 pole electrical trailer connector - ADR certified
- **TBC-EC**
- **RUP-FIX2** Fixed rear EC approved aluminium underrun
- **RFEND-T** Mudwings on drive axle for transportation only

WHEELS & TYRES

- **SPWT-F** Spare wheel & tyre with front tyre pattern
- **SWCP-LF** Spare wheel carrier on left side of chassis ahead of rear axle
- **SWCP-R** Spare wheel carrier rear mounted below frame.
- **SWCP-T** Spare wheel supplied temporarily strapped to chassis
- **SWCP-TP** Spare wheel carrier transport mounted on frame (spare wheel carrier not included)
- **JACK-8T** 8 tonne bottle jack
- **GAUGE-TP** Tyre pressure gauge

DRIVELINE EQUIPMENT

- **CS39A-O** Single plate 395mm (16") clutch
- **RET-TPT** Retarder for automatic gearbox
- **TC-HWO** Automatic gearbox oil cooler - water to oil
- **1COMP500** Single cylinder air compressor 360 cc / 500 l/min
- **AIRIN-FR** Front air intake
- **AIRIN-HI** High air intake behind cab on left hand side
- **AIRIN-RL** Chassis mounted mounted behind cab on right hand side
- **ACL1ST** Air cleaner with one filter element
- **ACL1ST-S** Air filter with secondary filter element
- **24AL110B** 110 amp alternator
- **24AL130B** 130 amp alternator
- **CCV-C** Closed crankcase ventilation
- **CCV-OX** Open crankcase ventilation with oil separator and a maintenance free gas centrifuge
- **EST-AID** Air inlet manifold starting heater element
- **PTER-100** Rear engine mounted power-take-off with DIN 7476 flange
- **PTER-DIN** Rear engine mounted PTO with DIN5462 (female) splined shaft for a close coupled pump
- **PTER1400** Rear engine mounted power-take-off with SAE 1410 flange
- **PR-HF4S** Live-drive PTO for Allison gearbox output 400Nm for flange connection mounted on the side of the torque convertor
- **PR-HF4SH** Live-drive high speed PTO for Allison gearbox output 400Nm for hydraulic pump connection mounted on the side of the torque convertor
- **PR-HF6S** Live-drive PTO for Allison gearbox output 600Nm for flange connection mounted on the side of the torque convertor
- **PR-HP4S** Live-drive PTO for Allison gearbox output 400Nm for hydraulic pump connection mounted on the side of the torque convertor
- **PR-HP4SH** Live-drive high speed PTO for Allison gearbox output 400Nm for hydraulic pump connection mounted on the side of the torque convertor
- **PR-HP6S** Live-drive PTO for Allison gearbox output 600Nm for hydraulic pump connection mounted on the side of the torque convertor
- **PTR-FH1** Rear PTO Gearbox S81 flange DIN connection
- **PTR-FH2** Rear PTO Gearbox S84 flange DIN connection
- **PTR-FH5** Rear PTO Gearbox S88 flange DIN connection
- **PTR-PH1** Rear PTO Gearbox S81 pump DIN connection
- **PTR-PH2** Rear PTO Gearbox S84 pump DIN connection
- **PTR-PH4** Rear PTO Gearbox S88 pump DIN connection
- **PTR-PK** Electrical and solenoid prep kit for gearbox PTO
- **PTR-ZF2** Rear Power Take Off flange DIN connection
- **PTR-ZF3** Rear Power Take Off Gearbox pump DIN connection

■ Standard Equipment □ Optional Equipment

For more detailed information about cab and powertrain equipment, please refer to separate specification sheets.

For all possible options and combinations of options please consult your Volvo sales contact who can create a specification to match your requirements using the Volvo Sales Support system (VSS).

The factory reserves the right to modify design and change equipment without previous notification. The specification can vary from country to country.

MODEL RANGE

FL516 4x2 Platform 16 tonne - Rear Air Suspension FL 42 R 516A

- PTR-ZF4** Rear PTO Gearbox 320Nm flange connection
- PTR-ZF5** Rear PTO Gearbox 320Nm pump connection
- PTR-ZF6** Rear PTO Gearbox 320Nm flange connection

- HPG-F101** Gearbox mounted hydraulic pump F1-101, fixed displacement, single flow.
- HPG-F41** Gearbox mounted hydraulic pump F1-41, fixed displacement, single flow.
- HPG-F51** Gearbox mounted hydraulic pump F1-51, fixed displacement, single flow.
- HPG-F61** Gearbox mounted hydraulic pump F1-61, fixed displacement, single flow.
- HPG-F81** Gearbox mounted hydraulic pump F1-81, fixed displacement, single flow.

- ETC** Electronic throttle control - dash mounted switch for PTO speed control

CAB INTERIOR

- **STWPOS-R** RIGHT HAND DRIVE

CAB EXTERIOR

- SUNV-B** Exterior sun visor - smoked grey
- **SUNV-PK** Sunvisor installation preparation kit

- AD-ROOF** Fixed cab roof air deflector - not adjustable

- AD-SIDES** Cab side air deflector, short extension panels.

- BEACON-P** Beacon preparation
- BEACONA2** Two amber beacons directly mounted to cab roof

SUPERSTRUCTURE PREPARATIONS

- FBA-BTF** Lower front body attachments for torsionally flexible - platform body
- FBA-BTSF** Lower front body attachments for torsionally semi-flexible body - box or curtainsider

- RBA-T2** Rear body attachments, divided

- TAILPREP** Taillift preparation kit - cab switch and warning in driver display

DELIVERY SERVICES

- **WVTA** Whole Vehicle Type Approved - MANDATORY for standard truck

VOLVO

Volvo Truck Corporation
volvotrucks.com