

- **Dumpers hidrostáticos**

- **Hydrostatic dumpers** • Dumper hydrostatiques

Modelos • Models • Modèles

- **DH - 600 AHG**



	DH-600 AHG
A	4.600
B	2.875
C	2.200
D	2.500
E	430
G (Via delantera)	1.800
H (Via trasera)	1.800
Radio Giro Exterior	5,50 m
Radio Giro Interior	3,30 m

Dimensiones • **Dimensions** • **Dimensions**

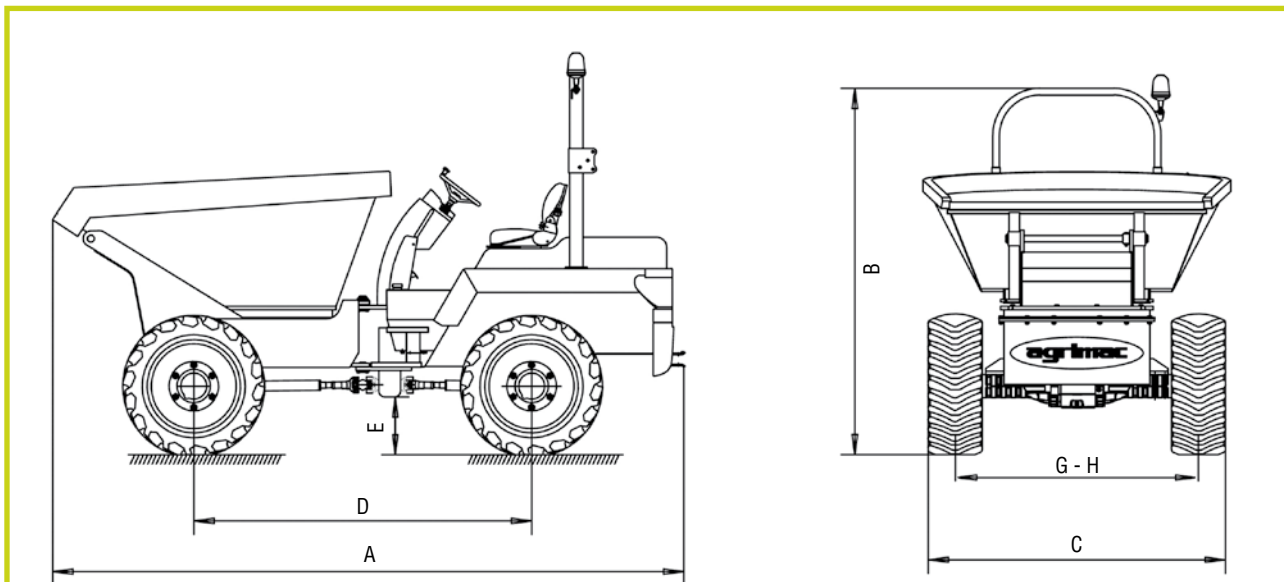

• DH - 600 AHG • DUMPER

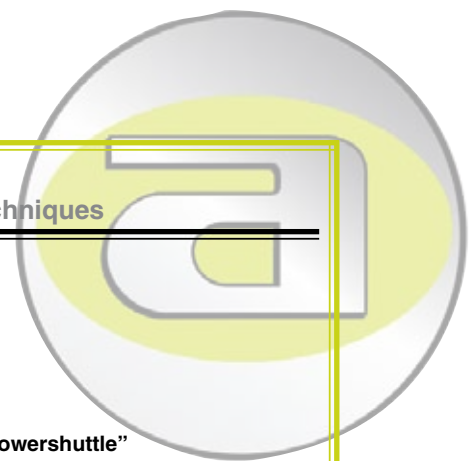

Características Técnicas • Technical Features • Caracteristiques Techniques



CARGA ÚTIL	Tolva con sistema de descarga giratoria a 180º, 6.000 Kg.
NIVEL AGUA	1.650 L
COLMADA	3,2 m ³
PENDIENTE MAX.	58 %
MOTOR	Diesel perkins 4 Cilindros. 85 CV. Refrigerado por agua
TRANSMISIÓN	Hidrodinámica con convertidor de par, CAT. cambio sincronizado "powershuttle"
VELOCIDADES	4 velocidades desde: 5,2 Kms/h a 33,20 Kms/h
DIRECCIÓN	Vehículo articulado, dirección hidrostática con 2 cilindros de doble efecto.
NEUMÁTICOS	405 / 70 R 20
FRENOS	Servicio a las 4 ruedas, discos multiples. Estacionamiento: a las ruedas traseras



USEFUL LOAD	<i>Hopper with lateral 180º Discharge, 6.000 Kg</i>
WATER LEVEL	<i>1.650 L</i>
FULL TO THE BRIM	<i>3,2 m³</i>
MAX. GRADABILITY	<i>58%</i>
ENGINE	<i>Diesel Perkins 4 Cylinders. 85 H.P. Water cooled</i>
TRANSMISSION	<i>Hidrodinamic with CAT. par, converter and synchronized change "powershuttle"</i>
SPEEDS	<i>Progressive automatic speed travel: 4 speed range from 5,2 Kms/h to 33,20 Kms/h</i>
STEERING	<i>Articulated vehicle, with hidrostatic steering and priority valve</i>
WHEELS	<i>405 / 70 R 20</i>
BRAKES	<i>Service Brake: Multiple disc on rear wheels. Parking Brake on the rear axle</i>



CHARGE UTILE	Benne avec système de decharge 180º. 6.000 Kg
NIVEAU DE EAU	1.650 L
PLEIN	3,2 m ³
DECLIVITE MAX	58%
MOTEUR	Diesel Perkins 4 Cylindres. 85 H.P. Per eau
TRANSMISSION	Hidrodinamic avec par converter CAT. et syncro "powershuttle"
VITESSES	Regulation automatique de vitesses avec 4 vitesses 5,2 Kms/h a 33,20 Kms/h
DIRECTION	Vehicule articule: direction hydraulique et valve de priorite
ROUES	405 / 70 R 20
FREINS	De service: Multiple disques sur les arrières roues. Stationnement: Pont arriere