

MINICHARGEUR T985



MINICHARGEUR SUR CHENILLES



MINICHARGEUR T985

POIDS EN ORDRE DE MARCHE/CHARGE UTILE NOMINALE

T985.32 Kg. 4.550/Kg. 1.470

T985.45 Kg. 4.700/Kg. 1.592

PUISSANCE MOTEUR

Kw 72,8

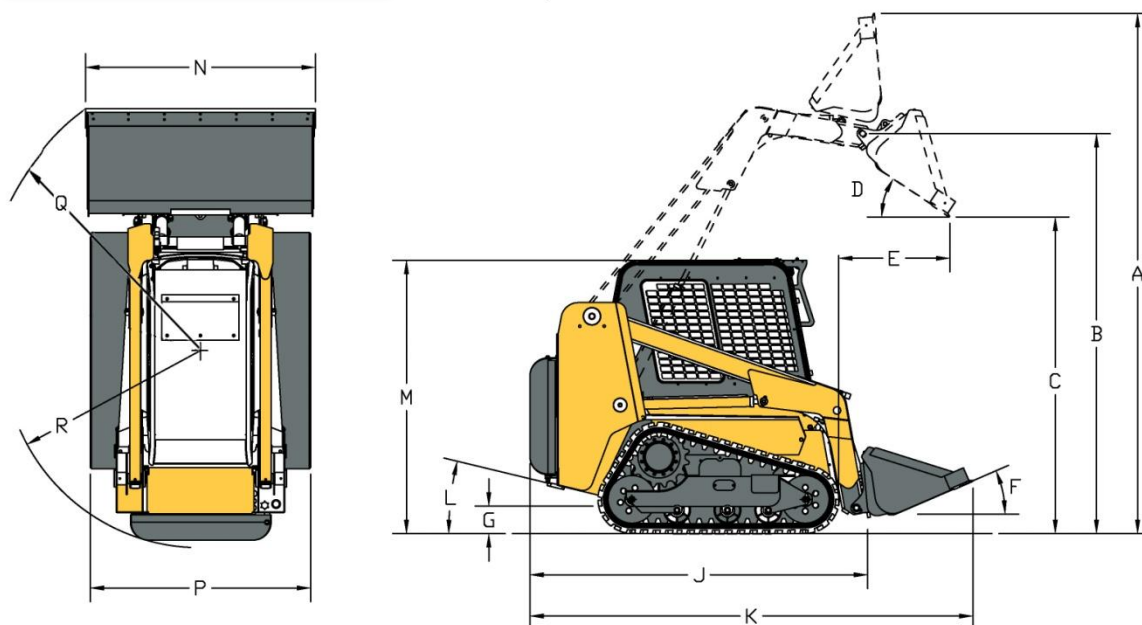

DIMENSIONS		T985.32	T985.45
A – Hauteur max de fouille	mm	4.075	
B – Hauteur pivot godet	mm	3.098	
C – hauteur de déversement	mm	2.281	
D – Angle de déversement	°	40	
E – Distance de déversement à hauteur Max	mm	810	
F – Angle fermeture godet	°	31	
G – Hauteur min. du sol	mm	205	
H – entre axe	mm	2.769	
J – Longueur totale sans godet	mm	3.482	
K – Longueur tot. Avec godet standard	°	29	
L – Angle de départ arrière	mm	2.079	
M – Hauteur max machine	mm	1.980	2.170
N – Largeur max avec godet standard	mm	1.930	2.155

CARACTERISTIQUES TECHNIQUES		T985.32	T985.45
Poids en ordre de marche	Kg	4550	4600
Charge utile nominale 50%	Kg	1470	1592
Charge utile nominale 35%	Kg	1030	1114
Charge de basculement	Kg	2942	3183
Vitesse de déplacement	Km/h	0-8,5/13,5	
Réservoir Huile / Gasoil	l	38/66	
Moteur		KUBOTA	
Cylindrée	cc	3.800 turbo	
Puissance / Rpm	Kw	72,8 / 2600	
Pompes hydrostatiques	bar l/min	350 2x125	
Pompe de service	bar l/min	180 77,5	
Pompe high flow	bar l/min	180 180	
Refroidissement		Eau/Air	
Patins de chenilles	320x86x52 2	450x86x52	

CAMS MACCHINE S.P.A.

Strada S. Michele, 37 Cailungo B5 BORGO MAGGIORE R.S.M.

Tel. +378.0549.988111 Fax +378.0549.903793

www.camsgroup.com info@camsgroup.com

