

4640

FORESTRY EQUIPMENT

Timber Loaders • Road Builders

SPES

Link-Belt
FORESTRY



PURPOSE-BUILT FOR THE WORK YOU DO

Link-Belt Forestry machines are designed and built with you in mind. Whether you're pioneering sites, building access roads, harvesting timber, processing logs or loading trucks at the mill yard, we've got the right equipment for the job. The new Link-Belt 4640 forestry machine features a powerful, fuel-efficient Final Tier 4 engine that doesn't require a Diesel Particulate Filter (DPF), matched to a 41% larger fuel tank that keeps you working longer. 4640 forestry machines offer best-in-class swing torque, and up to 12% better fuel economy. This attention to detail insures that Link-Belt Forestry machines deliver outstanding performance and productivity where it matters most. We focus on the machine so you can focus on your work.



ATTENTION TO DETAILS AT EVERY LEVEL

- (A)** Oregon OSHA/WCB-certified cabs are 8082-2 compliant; available with sky roof and escape hatch. Choose rear-entry or side-entry cabs and risers; impact-resistant polycarbonate windows.
- (B)** 7" high-definition color monitor; full-time rear-view camera is standard. RemoteCARE® telematics keeps a watchful eye on performance, maintenance intervals and theft deterrence.
- (C)** Superior maneuverability and fine control, with dedicated control valve for application and forestry-exclusive circuit for arm-in-arm regeneration and arm-2 spool.
- (D)** Convenient ticket slot; operator doesn't have to bend down to hand the truck driver a log ticket.



- (E)** Faster cycle time and attachment speed:
- 30% faster boom-down/arm-in
 - 19% faster boom up/swing
 - Up to 10% bonus lifting capacity due to wider lifting area and rear-mounted counterweight
- (F)** Heavy-duty components built for the woods include house doors; covers; protective guards; redesigned undercarriage; reinforced boom foot revolving frame; factory-fabricated attachment with optimized heel.
- (G)** Tough, field-repairable parts include 3-pc. steel engine hood; add-on hockey stick; LED lights and no-bolt oil filler.
- (H)** Servicing is a snap, with convenient access to all routine service points, including sample ports for engine and hydraulic oil. All service ports can be accessed via hand-turn knobs, no tools needed.





TIMBER LOADER SPECIFICATIONS

Engine

Isuzu AQ-6HK1X Final Tier 4 turbocharged diesel engine with electronic control (ECM) and high pressure common-rail fuel injection, 6-cylinder, water-cooled, cooled Exhaust Gas Recirculation (EGR), Intercooler, Variable-Geometry Turbocharger (VGT), Diesel Oxidation Catalyst (DOC) and Selective Catalytic Reduction (SCR) system with Dosing Control Module (DCM) and heated DEF lines. Electronic fuel pump and priming, Fuel cooler, Auto-idle start, Auto warm-up, EPF engine protection, dual-stage fuel filtration, remote oil filter, engine oil sample port, green plug oil drain, double element air filter.

SAE J 1349 net hp 268 HP (200 kW) @ 1,900 rpm
 Displacement 7.8 L
 Maximum torque 729 lbf-ft (988 N-m) @ 1,500 rpm
 Starter..... 24V-5.0kW
 Alternator..... 90 amp
 Battery (2) 12-volt 128 amp hours

Cab and Controls

Oregon OSHA/ROPS/WCB compliant side-entry forestry cab, 48" hydraulic tilting riser, (8) LED exterior work lights, Key Fob with remote light functionality, Sirius® Satellite and iPod® ready sound system with AM/FM, MP3 interface, dual speakers and mute button, SCM high-back air-suspension seat, Sliding/reclining, adjustable armrests, lumbar support, retractable seat belt and foot rests, +/- 5 degree tilt, Control panel with illuminated soft-touch switches, High definition LCD monitor with full color 7" display, 2-position LED swivel map lights with red ambient illumination for safety and night vision compatibility, Low-effort controls pre-wired for auxiliary hydraulics, Sliding 4-position tilting control consoles, Climate control, Job ticket slot, CB radio antenna mounting provision, Sky roof, Single motor dual arm intermittent/continuous windshield wiper with washer, Single pedal travel, Travel alarm with cancellation switch, Footrests, Cup holder, 12-volt outlet, Digital clock, 24-volt cigarette lighter, Ashtray, Dome lights, Coat hook, High output dual horns, Handrails with deflector, Floor mat, Emergency exit.

Three selectable working modes, Anti-theft password protection system, On-board self-diagnostic system with memory and service interval reminders, Free Swing control, Auto-idling system, One-touch decelerator, Auto-idle engine shutdown, Boom/Bucket Spool Stroke Control (SSC), Attachment Cushion Control, Neutral safety start, Gate-lock safety shutoff, RemoteCARE Telematics with 6 year free subscription.

Hydraulic System

Open-center system, (2) variable displacement axial piston pumps, (1) gear pump for pilot controls, (1) gear pump/valve for grapple rotate, Dedicated and proprietary main control valve tuned for enhanced TL performance with one 4-spool valve and one 5-spool valve with auxiliary spool, Programmable auxiliary pump settings with single or double pump control, Grapple Circuit Control Valve for Live-Heel attachment (Squeeze circuit), Oil cooler, O-ring face seals, High-performance 6-micron return filter, Hydraulic oil sample port, Firewall.

Hydraulic Pumps

Maximum flow 2 x 79.3 gpm (2 x 300 l/min)
 Pilot pump maximum flow 7.5 gpm (28.5 l/min)
 Auxiliary pump maximum flow ... 9.2 gpm (35.0 l/min)

Relief Valve Settings

Boom/arm/tool 4,970 psi (343 bar)
 Swing circuit 4,270 psi (294 bar)
 Travel..... 4,970 psi (343 bar)

Hydraulic Oil Filtration

Return filter..... 6 micron
 Pilot filter..... 8 micron
 Suction screen 105 micron

Swing

Planetary reduction powered by axial piston motor. Internal ring gear with grease cavity for swing pinion. Swing bearing is single-row shear type ball bearing. Mechanical disc swing brake. Free swing control.

Swing speed..... 0 - 7.6 rpm
 Tail swing 12' 3" (3.74 m)
 Swing torque 110,600 lbf-ft. (150 kN•m)

Undercarriage

High-Wide track gauge with x-pattern carbody, Full-length track guards (2 piece, bolt-on), Sealed and strutted track chain, Sealed rollers and idlers, Idler mount reinforcement, Two-speed independent hydrostatic travel with planetary final drive, HD travel motor covers, Disc type brakes, Adjustable track tension, HD swivel guard.

Carrier rollers..... 2 per side
 Track rollers..... 9 per side
 Track link pitch..... 8.50" (216 mm)
 Shoes 50 per side
 Shoe width..... 27.5" (700 mm)
 Ground Pressure (less cab) ... 10.3 psi (0.071 MPa)

Lubricant & Coolant Capacity

Fuel tank..... 216 gal. (820 liters)
 Hydraulic tank..... 46 gal. (175 liters)
 Hydraulic system 92 gal. (350 liters)
 Final drive (per side) 2.6 gal. (10 liters)
 Swing drive 2.8 gal. (10.5 liters)
 Engine oil..... 12.7 gal. (48 liters)
 DEF Tank..... 40 gal. (152 liters)
 Cooling system..... 10 gal. (38 liters)

Travel System

Two-speed independent hydrostatic travel with axial piston motors. Hydraulic motor powered output shaft coupled to a planetary reduction unit and track sprocket. All hydraulic components mounted within the width of side frame. Automatic downshift. Single pedal travel. Spring applied, hydraulically released disc parking brake built into each motor. Each travel motor equipped with counterbalance valve to prevent overspeeding down an incline.

Max. travel speed 1.9 - 3.1 mph (3.0 - 5.0 km/h)
 Drawbar pull 68,800 lbf (306 kN)
 Gradeability 70% (35°)

Attachment

Factory designed and built attachment, Arm cylinder guard, Grapple Circuit Control Valve (squeeze circuit)

Boom 23' 2" (7.06 m)
 Arm 16' 4" (4.98 m)

Operating Weight - No Tool

Working weight with side-entry forestry cab, 48" (1.22 m) cab riser, live-heel logging attachment, high-wide undercarriage, 27.5" (700 mm) 2-bar shoes
 103,271 lbs (46 843 kg)
 Working weight with rear-entry forestry cab, live-heel logging attachment, high-wide undercarriage, 27.5" (700 mm) 2-bar shoes
 104,314 lbs (47 316 kg)

TIMBER LOADER WORKING RANGE

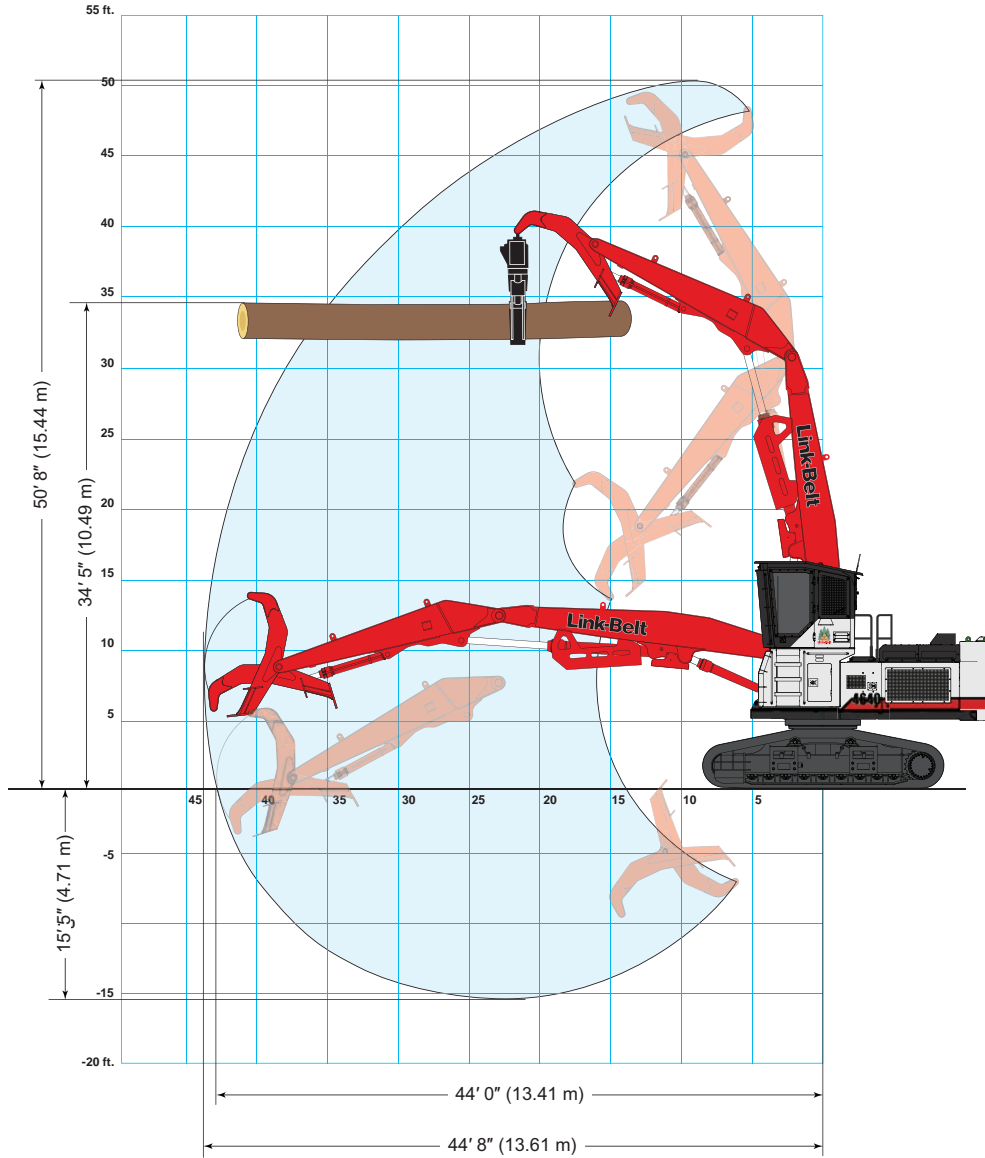

Machine equipped with logging attachment	
A. Maximum reach	44' 8" (13.61 m)
B. Maximum reach @ ground level	44' 0" (13.41 m)
C. Maximum depth	15' 5" (4.71 m)
D. Maximum height	50' 8" (15.44 m)
E. Maximum log level height	34' 5" (10.49 m)
F. Heel wrist action	103°
Working range shown at grapple pin location with live-heel extended	

TIMBER LOADER TRAVEL DIMENSIONS

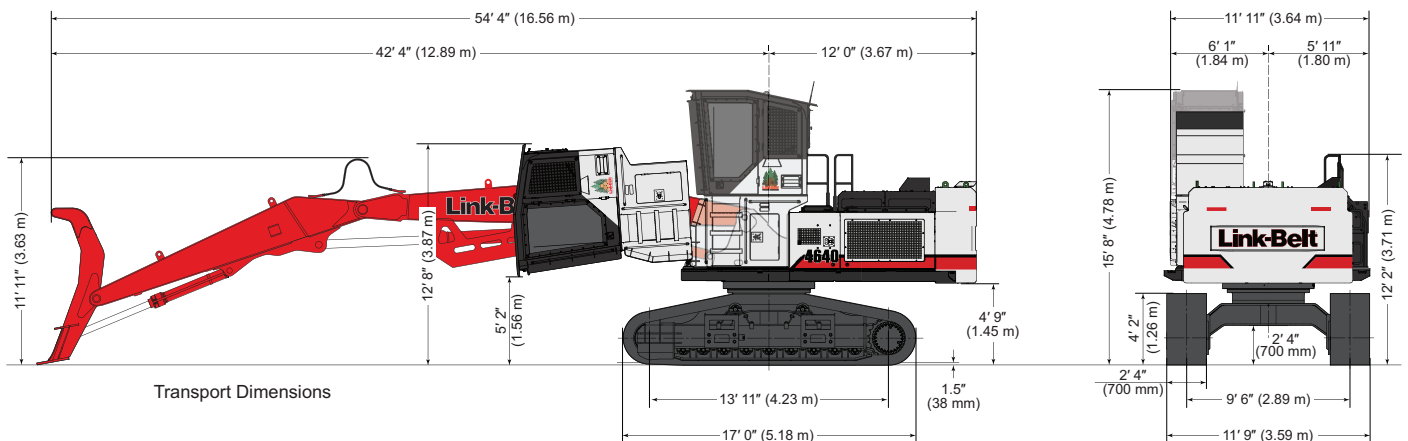

TIMBER LOADER LIFTING CAPACITIES

		Radius of Load																	
		16' 4" (4.98 m) Arm with 23' 2" (7.06 m) Boom and Live-Heel (High Wide Undercarriage)																	
End	Side	10' 0" (3.0 m)		15' 0" (4.5 m)		20' 0" (6.0 m)		25' 0" (7.5 m)		30' 0" (9.0 m)		35' 0" (10.5 m)		40' 0" (12.0 m)		Max. Reach			
		End	Side	End	Side	End	Side	End	Side	End	Side	End	Side	End	Side	End	Side		
+45' 0"	lbs					25,650*	25,650*											22,850*	22,850*
(13.5 m)	kg					11 630*	11 630*											10 360*	10 360*
+40' 0"	lbs							24,050*	24,050*	18,400*	17,300							18,850*	17,100
(12.0 m)	kg							10 910*	10 910*	8 350*	7 840							8 540*	7 750
+35' 0"	lbs							24,950*	24,500	22,550*	17,800	16,600*	13,450					16,800*	13,500
(10.5 m)	kg							11 320*	11 120	10 230*	8 070	7 520*	6 100					7 620*	6 130
+30' 0"	lbs							24,700*	24,400	22,500*	17,800	19,300	13,400					15,650*	11,500
(9.0 m)	kg							11 210*	11 060	10 210*	8 070	8 750	6 090					7 100*	5 220
+25' 0"	lbs					23,650*	23,650*	25,200*	24,250	22,700*	17,650	19,200	13,350	15,200	10,350			14,900	10,250
(7.5 m)	kg					10 730*	10 730*	11 430*	11 000	10 310*	8 000	8 710	6 060	6 880	4 700			6 750	4 640
+20' 0"	lbs					19,450*	19,450*	25,900*	23,950	23,300*	17,550	19,100	13,250	15,000	10,200			13,800	9,450
(6.0 m)	kg					8 820*	8 820*	11 750*	10 860	10 570*	7 960	8 660	6 000	6 810	4 640			6 260	4 280
+15' 0"	lbs					19,800*	19,800*	27,900*	23,300	24,100*	17,250	19,000	13,150	14,850	10,050			13,150	8,950
(4.5 m)	kg					8 980*	8 980*	12 660*	10 580	10 940*	7 820	8 610	5 960	6 740	4 560			5 960	4 050
+10' 0"	lbs					28,350*	28,350*	29,550*	22,500	24,200	16,800	18,750	12,950	14,850	10,100			12,800	8,650
(3.0 m)	kg					12 860*	12 860*	13 410*	10 200	10 980	7 620	8 510	5 870	6 740	4 570			5 810	3 930
+5' 0"	lbs					38,800*	30,400	30,700*	21,600	23,700	16,300	18,500	12,700	14,800	10,050			12,200*	8,650
(1.5 m)	kg					17 590*	13 790	13 920*	9 810	10 740	7 400	8 400	5 760	6 720	4 550			5 550*	3 910
Ground	lbs			34,300*	34,300	39,400*	28,600	30,500	20,650	23,100	15,750	18,300	12,500	11,800*	10,000			10,600*	8,800
Line	kg			15 560*	15 560	17 870*	12 960	13 830	9 360	10 480	7 160	8 290	5 660	5 360*	4 530			4 820*	3 990
-5' 0"	lbs			19,450*	19,450*	35,500*	27,350	27,700*	19,850	21,550*	15,300	15,750*	12,200	11,300*	10,000			10,450*	9,350
(1.5 m)	kg			8 830*	8 830*	16 100*	12 410	12 570*	9 010	9 770*	6 930	7 130*	5 530	5 130*	4 540			4 750*	4 250
-10' 0"	lbs	9,150*	9,150*	16,000*	16,000*	28,650*	26,750	22,550*	19,400	16,850*	15,000	13,550*	12,050					11,950*	10,900
(3.0 m)	kg	4 150*	4 150*	7 260*	7 260*	12 990*	12 130	10 220*	8 810	7 630*	6 810	6 140*	5 470					5 430*	4 940
-15' 0"	lbs					25,300*	25,300*	19,700*	19,350									17,400*	16,750
(4.5 m)	kg					11 490*	11 490*	8 940*	8 770									7 880*	7 600

REAR-ENTRY FORESTRY CAB

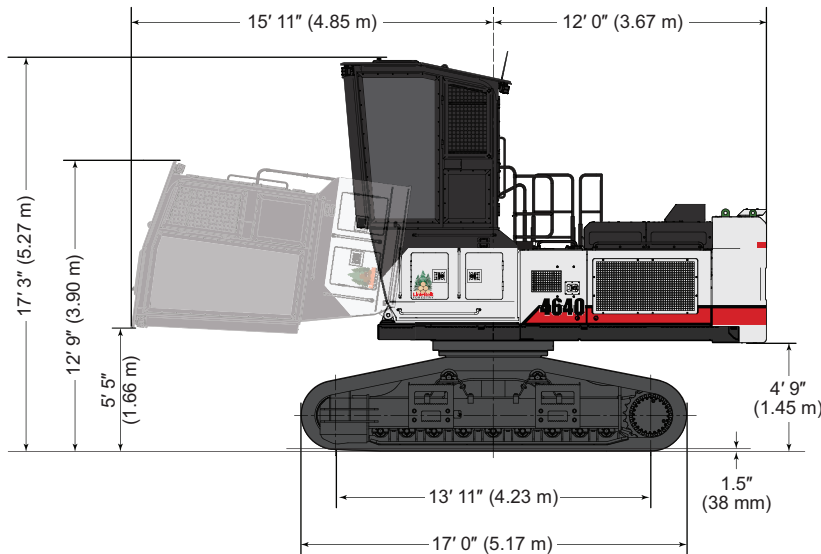

Notes: Lifting capacities

- Lifting capacities shown should not be exceeded. Weight of all lifting accessories must be deducted from the above lifting capacities. Lifting capacities for Log Loader attachment include a heel rack, but not grapple. Addition of grapple weight must be deducted from lift capacities.
- Lifting capacities are based on machine standing on firm, uniform supporting surface. User must make allowances for job conditions such as soft or uneven ground.
- Lifting capacities shown do not exceed 75% of minimum tipping loads or 87% of hydraulic capacities. Capacities marked with an asterisk (*) are limited by hydraulic capacities.
- Least stable position is over the side.
- Operator should be fully acquainted with the Operator's Manual & Operating Safety Booklet, furnished by LBX before operating the machine.
- Capacities apply only to the machine as originally manufactured and normally equipped by LBX Company LLC.

**LINK-BELT FORESTRY MACHINES ARE
DESIGNED AND BUILT WITH YOU IN MIND.**



Link-Belt
FORESTRY



ROAD BUILDER SPECIFICATIONS

Engine

Isuzu AQ-6HK1X Final Tier 4 turbocharged diesel engine with electronic control (ECM) and high pressure common-rail fuel injection, 6-cylinder, water-cooled, cooled Exhaust Gas Recirculation (EGR), Intercooler, Variable-Geometry Turbocharger (VGT), Diesel Oxidation Catalyst (DOC) and Selective Catalytic Reduction (SCR) system with Dosing Control Module (DCM) & heated DEF lines. Electronic fuel pump and priming, Fuel cooler, Auto-idle start, Auto warm-up, EPF engine protection, dual-stage fuel filtration, remote oil filter, engine oil sample port, green plug oil drain, double element air filter.

SAE J 1349 net hp 268 HP (200 kW) @ 1,900 rpm
 Displacement 7.8 L
 Maximum torque 729 lbf-ft (988 N-m) @ 1,500 rpm
 Starter 24V-5.0kW
 Alternator 90 amp
 Battery (2) 12-volt 128 amp hours

Cab and Controls

Oregon OSHA/ROPS/WCB compliant side-entry forestry cab, 12" riser, (8) LED exterior work lights, Key Fob with remote light functionality, Sirius® Satellite and iPod® ready sound system with AM/FM, MP3 interface, dual speakers and mute button, SCM high-back air-suspension seat, Sliding/reclining, adjustable armrests, lumbar support, retractable seat belt and foot rests, +/- 5 degree tilt, Control panel with illuminated soft-touch switches, High definition LCD monitor with full color 7" display, 2-position LED swivel map lights with red ambient illumination for safety and night vision compatibility, Low-effort controls pre-wired for auxiliary hydraulics, Sliding 4-position tilting control consoles, Climate control, Job ticket slot, CB radio antenna mounting provision, Sky roof, Single motor dual arm intermittent/continuous windshield wiper with washer, Single pedal travel, Travel alarm with cancellation switch, Footrests, Cup holder, 12-volt outlet, Digital clock, 24-volt cigarette lighter, Ashtray, Dome lights, Coat hook, High output dual horns, Floor mat, Emergency exit.

Three selectable working modes, Anti-theft password protection system, On-board self-diagnostic system with memory and service interval reminders, Free Swing control, Auto-idling system, One-touch decelerator, Auto-idle engine shutdown, Boom/Bucket Spool Stroke Control (SSC), Attachment Cushion Control, Neutral safety start, Gate-lock safety shutoff, RemoteCARE Telematics with 6 yr. free subscription.

Hydraulic System

Open-center system, (2) variable displacement axial piston pumps, (1) gear pump for pilot controls, (1) gear pump/valve for grapple rotate, Dedicated and proprietary main control valve tuned for enhanced performance with one 4-spool valve and one 5-spool valve with auxiliary spool, Programmable auxiliary pump settings with single or double pump control, Oil cooler, O-ring face seals, High-performance 6-micron return filter, Hydraulic oil sample port, Firewall.

Hydraulic Pumps

Maximum flow 2 x 79.3 gpm (2 x 300 l/min)
 Pilot pump maximum flow 7.5 gpm (28.5 l/min)
 Auxiliary pump maximum flow ... 9.2 gpm (35.0 l/min)

Relief Valve Settings

Boom/arm/bucket 4,970 psi (343 bar)
 Swing circuit 4,270 psi (294 bar)
 Travel 4,970 psi (343 bar)

Hydraulic Oil Filtration

Return filter 6 micron
 Pilot filter 8 micron
 Suction screen 105 micron

Swing

Planetary reduction powered by axial piston motor. Internal ring gear with grease cavity for swing pinion. Swing bearing is single-row shear type ball bearing. Mechanical disc swing brake. Free swing control.

Swing speed 0 – 7.6 rpm
 Tail swing 12' 3" (3.74 m)
 Swing torque 110,600 lbf-ft. (150 kN•m)

Undercarriage

High-Wide track gauge with x-pattern carbody, Full-length track guards (2 piece, bolt-on), Sealed and strutted track chain, Sealed rollers and idlers, Idler mount reinforcement, Two-speed independent hydrostatic travel with planetary final drive, HD travel motor covers, Disc type brakes, Adjustable track tension, HD swivel guard.

Carrier rollers 2 per side
 Track rollers 9 per side
 Track link pitch 8.50" (216 mm)
 Shoes 50 per side
 Shoe width 27.5" (700 mm)
 Ground Pressure (less cab) 9.7 psi (0.067 MPa)

Lubricant & Coolant Capacity

Fuel tank 216 gal. (820 liters)
 Hydraulic tank 46 gal. (175 liters)
 Hydraulic system 92 gal. (350 liters)
 Final drive (per side) 2.6 gal. (10 liters)
 Swing drive 2.8 gal. (10.5 liters)
 Engine oil 12.7 gal. (48 liters)
 DEF Tank 40 gal. (152 liters)
 Cooling system 10 gal. (38 liters)

Travel System

Two-speed independent hydrostatic travel with axial piston motors. Hydraulic motor powered output shaft coupled to a planetary reduction unit and track sprocket. All hydraulic components mounted within the width of side frame. Automatic downshift. Single pedal travel. Spring applied, hydraulically released disc parking brake built into each motor. Each travel motor equipped with counterbalance valve to prevent overspeeding down an incline.

Max. travel speed 1.9 - 3.1 mph (3.0 - 5.0 km/h)
 Drawbar pull 69,100 lbf (307 kN)
 Gradeability 70% (35°)

Attachment

Boom 21' 2" (6.45 m)
 Arm 10' 8" (3.25 m)

Operating Weight

Working weight with side-entry forestry cab, 12" (305 mm) cab riser, road builder attachment, 3,459 lb. (1 569 kg) 42" HDP bucket, high-wide undercarriage, 15,200 lb. (6 900 kg) counterweight, 27.5" (700 mm) 2-bar shoes
 102,193 lbs (46 354 kg)

ROAD BUILDER WORKING RANGE

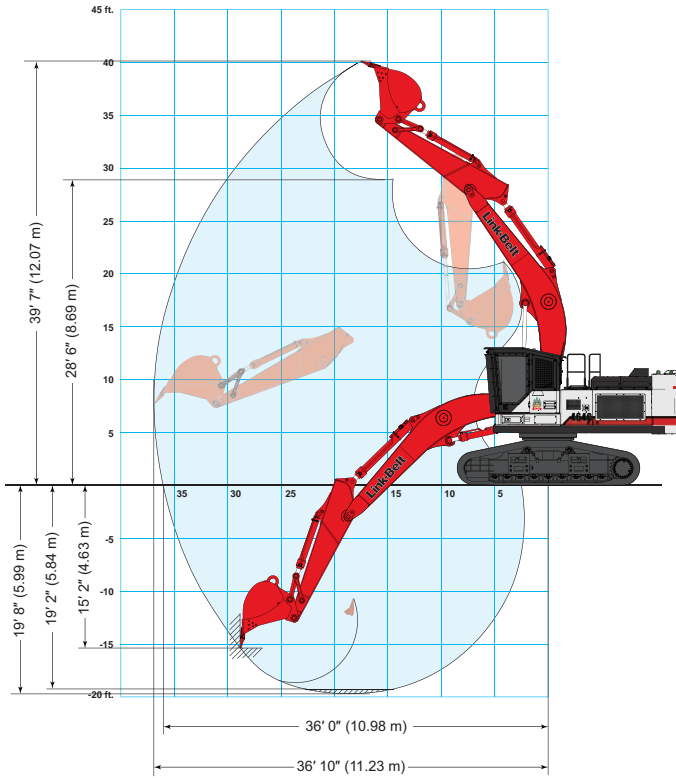

Boom Cylinders in High Lift Position

Machine Equipped with 21' 2" (6.45 m) Boom, 10' 8" (3.25 m) Arm	High Wide Undercarriage
A. Maximum reach	36' 10" (11.23 m)
B. Maximum reach @ ground level	36' 0" (10.98 m)
C. Maximum dig depth	19' 8" (5.99 m)
D. Maximum dig height	39' 7" (12.07 m)
E. Maximum dump height	28' 6" (8.69 m)
F. Digging depth 8' (2.44 m) level bottom	19' 2" (5.84 m)
G. Maximum vertical wall depth	15' 2" (4.63 m)

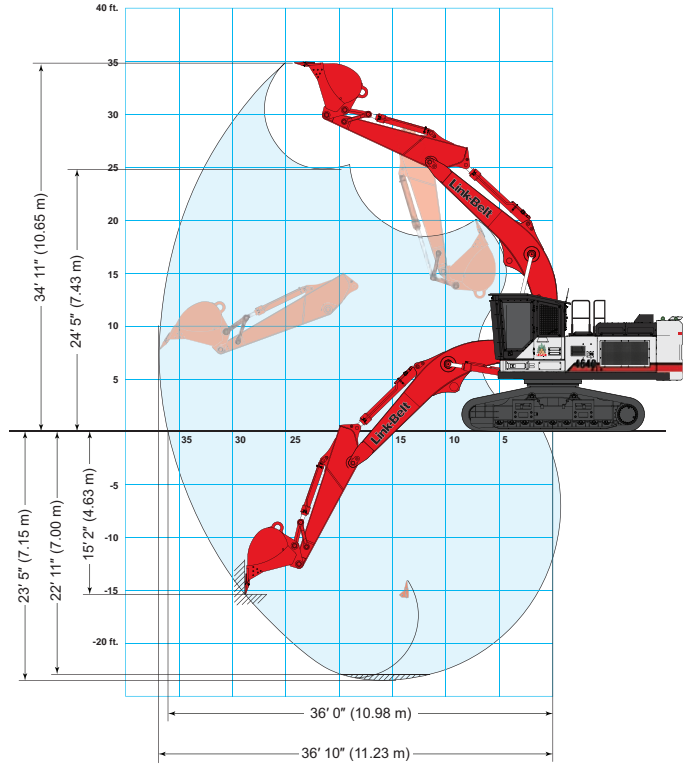

Boom Cylinders in Standard Position

Machine Equipped with 21' 2" (6.45 m) Boom, 10' 8" (3.25 m) Arm	High Wide Undercarriage
A. Maximum reach	36' 10" (11.23 m)
B. Maximum reach @ ground level	36' 0" (10.98 m)
C. Maximum dig depth	23' 5" (7.15 m)
D. Maximum dig height	34' 11" (10.65 m)
E. Maximum dump height	24' 5" (7.43 m)
F. Digging depth 8' (2.44 m) level bottom	22' 11" (7.00 m)
G. Maximum vertical wall depth	15' 2" (4.63 m)

ROAD BUILDER TRAVEL DIMENSIONS

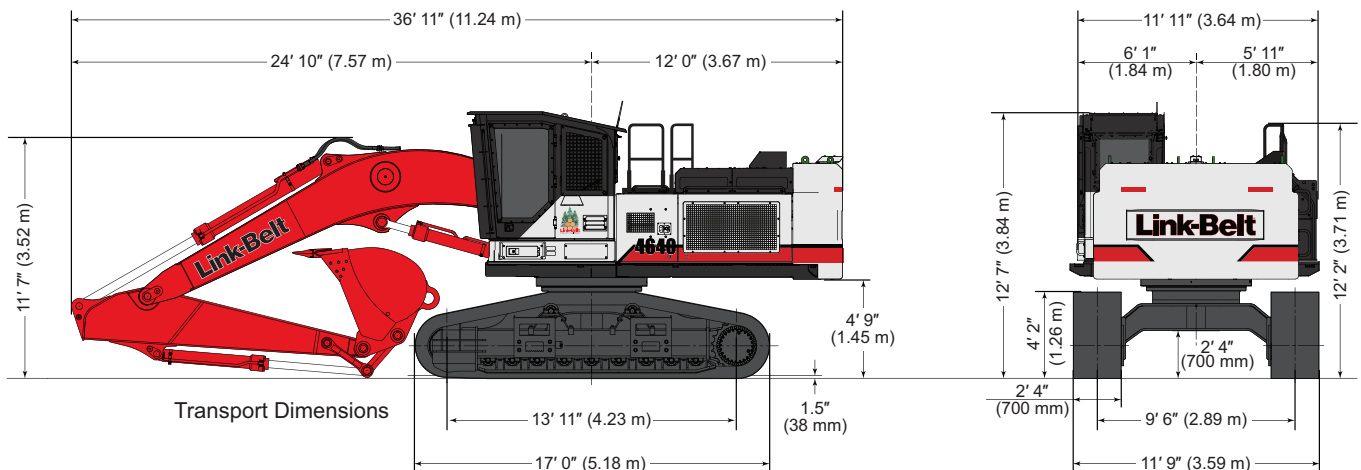

Transport Dimensions

ROAD BUILDER LIFTING CAPACITIES

Radius of Load																		
10' 8" (3.25 m) Arm with 21' 2" (6.45 m) Boom in Standard Position and 3,500 lb. (1 590 kg) Bucket (High Wide Undercarriage)																		
End	Side	5' 0" (1.5 m)		10' 0" (3.0 m)		15' 0" (4.5 m)		20' 0" (6.0 m)		25' 0" (7.5 m)		30' 0" (9.0 m)		35' 0" (10.5 m)		Max. Reach		
		End	Side	End	Side	End	Side	End	Side	End	Side	End	Side	End	Side	End	Side	
+30' 0"	lbs																7,650*	7,650*
	kg																3,450*	3,450*
+25' 0"	lbs											11,950*	11,950*				7,250*	7,250*
	kg											5,910*	5,910*				3,300*	3,300*
+20' 0"	lbs										15,050*	15,050*	13,650*	13,650*			7,200*	7,200*
	kg										6,950*	6,950*	6,270*	6,270*			3,270*	3,270*
+15' 0"	lbs					26,250*	26,250*	20,700*	20,700*	17,150*	17,150*	14,800*	14,800*	9,326	9,326		7,350*	7,350*
	kg					12,170*	12,170*	9,600*	9,600*	7,930*	7,930*	6,820*	6,820*	4,230	4,230		3,340*	3,340*
+10' 0"	lbs			45,400*	45,400*	31,750*	31,750*	23,850*	23,850*	19,050*	19,050*	15,950*	15,200*	11,133*	11,133*		7,750*	7,750*
	kg			21,260*	21,260*	14,580*	14,580*	11,040*	11,040*	8,810*	8,810*	7,380*	7,050*	5,050*	5,050*		3,510*	3,510*
+5' 0"	lbs			21,350*	21,350*	36,900*	36,900*	26,450*	26,450*	20,500*	19,800*	16,700*	14,900*	11,023	11,023		8,200*	8,200*
	kg			9,230*	9,230*	16,940*	16,940*	12,240*	12,240*	9,480*	9,170*	7,720*	6,930*	5,000	5,000		3,720*	3,720*
Ground Line	lbs	14,750*	14,750*	23,550*	23,550*	38,750*	38,750*	27,850*	27,050*	21,200*	19,250*	16,900*	14,450*				9,100*	9,100*
	kg	6,670*	6,670*	10,420*	10,420*	17,800*	17,800*	12,880*	12,560*	9,800*	8,960*	7,820*	6,730*				4,130*	4,130*
-5' 0"	lbs	21,450*	21,450*	30,250*	30,250*	38,600*	38,600*	27,850*	26,450*	21,300*	18,850*	16,850*	14,250*				10,500*	10,500*
	kg	9,680*	9,680*	13,440*	13,440*	17,820*	17,820*	12,880*	12,300*	9,850*	8,760*	7,810*	6,620*				4,740*	4,740*
-10' 0"	lbs	28,850*	28,850*	40,400*	40,400*	36,700*	36,700*	26,900*	26,400*	20,450*	18,800*	15,150*	14,350*				12,800*	12,800*
	kg	12,940*	12,940*	17,900*	17,900*	16,960*	16,960*	12,440*	12,270*	9,510*	8,740*	7,200*	6,670*				5,780*	5,780*
-15' 0"	lbs	39,500*	39,500*	45,950*	45,950*	32,250*	32,250*	23,800*	23,800*	17,300*	17,300*						14,550*	14,550*
	kg	17,580*	17,580*	21,320*	21,320*	14,990*	14,990*	11,100*	11,100*	8,190*	8,190*						6,600*	6,600*
-20' 0"	lbs			32,700*	32,700*	23,600*	23,600*	16,150*	16,150*								13,200*	13,200*
	kg			15,480*	15,480*	11,210*	11,210*	7,890*	7,890*								6,050*	6,050*

Radius of Load																		
10' 8" (3.25 m) Arm with 21' 2" (6.45 m) Boom in High Lift Position and 3,500 lb. (1 590 kg) Bucket (High Wide Undercarriage)																		
End	Side	5' 0" (1.5 m)		10' 0" (3.0 m)		15' 0" (4.5 m)		20' 0" (6.0 m)		25' 0" (7.5 m)		30' 0" (9.0 m)		35' 0" (10.5 m)		Max. Reach		
		End	Side	End	Side	End	Side	End	Side	End	Side	End	Side	End	Side	End	Side	
+35' 0"	lbs																8,650*	8,650*
	kg																3,850*	3,850*
+30' 0"	lbs									13,600*	13,600*						7,650*	7,650*
	kg									6,370*	6,370*						3,450*	3,450*
+25' 0"	lbs									15,600*	15,600*	11,950*	11,950*				7,250*	7,250*
	kg									7,160*	7,160*	5,920*	5,920*				3,300*	3,300*
+20' 0"	lbs					16,950*	16,950*	19,500*	19,500*	18,450*	18,450*	15,650*	15,650*				7,200*	7,200*
	kg					7,890*	7,890*	9,000*	9,000*	8,540*	8,540*	7,390*	7,340*				3,270*	3,270*
+15' 0"	lbs					29,300*	29,300*	24,800*	24,800*	20,100*	20,100*	16,750*	15,800*	9,326	9,326		7,350*	7,350*
	kg					13,610*	13,610*	11,490*	11,490*	9,280*	9,280*	7,740*	7,370*	4,230	4,230		3,340*	3,340*
+10' 0"	lbs			54,400*	54,400*	36,950*	36,950*	27,000*	27,000*	21,200*	20,600*	17,150*	15,350*	11,133*	11,133*		7,750*	7,750*
	kg			22,370*	22,370*	17,020*	17,020*	12,490*	12,490*	9,790*	9,550*	7,940*	7,150*	5,050*	5,050*		3,510*	3,510*
+5' 0"	lbs			21,350*	21,350*	39,600*	39,600*	28,350*	28,000*	21,650*	19,950*	17,300*	14,850*	11,023	11,023		8,200*	8,200*
	kg			9,230*	9,230*	18,230*	18,230*	13,120*	12,980*	10,010*	9,270*	8,000*	6,910*	5,000	5,000		3,720*	3,720*
Ground Line	lbs	13,050*	13,050*	23,550*	23,550*	39,200*	39,200*	28,350*	27,000*	21,650*	19,250*	17,050*	14,450*				9,100*	9,100*
	kg	5,750*	5,750*	10,420*	10,420*	18,090*	18,090*	13,090*	12,540*	10,020*	8,940*	7,900*	6,720*				4,130*	4,130*
-5' 0"	lbs	21,450*	21,450*	30,250*	30,250*	36,700*	36,700*	27,100*	26,450*	20,650*	18,800*	15,650*	14,200*				10,500*	10,500*
	kg	9,680*	9,680*	13,440*	13,440*	16,940*	16,940*	12,530*	12,280*	9,580*	8,750*	7,330*	6,610*				4,740*	4,740*
-10' 0"	lbs			40,400*	40,400*	31,600*	31,600*	23,850*	23,850*	17,850*	17,850*	11,900*	11,900*				11,100*	11,100*
	kg			17,900*	17,900*	14,620*	14,620*	11,060*	11,060*	8,360*	8,360*	5,790*	5,790*				5,070*	5,070*
-15' 0"	lbs			29,250*	29,250*	23,300*	23,300*	17,700*	17,700*	11,850*	11,850*						8,600*	8,600*
	kg			13,680*	13,680*	10,920*	10,920*	8,350*	8,350*	5,790*	5,790*						3,960*	3,960*

Notes: Lifting capacities

- Lifting capacities shown should not be exceeded. Weight of all lifting accessories must be deducted from the above lifting capacities. Lifting capacities for Log Loader attachment include a heel rack, but not grapple. Addition of grapple weight must be deducted from lift capacities.
- Lifting capacities are based on machine standing on firm, uniform supporting surface. User must make allowances for job conditions such as soft or uneven ground.
- Lifting capacities shown do not exceed 75% of minimum tipping loads or 87% of hydraulic capacities. Capacities marked w/ an asterisk (*) are limited by hydraulic capacities.
- Least stable position is over the side.
- Operator should be fully acquainted with the Operator's Manual & Operating Safety Booklet, furnished by LBX before operating the machine.
- Capacities apply only to the machine as originally manufactured and normally equipped by LBX Company.

ROAD BUILDER BUCKET SIZES

Bucket Type	SAE Heaped Capacity (yd ³)	SAE Heaped Capacity (m ³)	Width Outside Lip (in/mm)		Bucket Weight (lbs/kg)		Number of Teeth	Arm Length 10' 8" (3.25 m)	
STDP Standard duty plate	1.26	0.96	30	762	2306	1046	4	H	
	1.59	1.22	36	914	2516	1141	4	H	
	1.92	1.47	42	1067	2786	1264	5	H	
	2.25	1.72	48	1219	2956	1341	5	H	
	2.59	1.98	54	1372	3226	1463	6	M	
	2.93	2.24	60	1524	3396	1540	6	L	
HDP Heavy duty plate	1.22	0.93	30	762	2886	1309	4	H	
	1.54	1.18	36	914	3131	1420	4	H	
	1.86	1.42	42	1067	3459	1569	5	H	
	2.19	1.67	48	1219	3704	1680	5	H	
	2.53	1.93	54	1372	4031	1828	6	M	
	XDP Extreme duty plate	1.22	0.93	30	762	3327	1509	4	H
1.54		1.18	36	914	3620	1642	4	H	
1.86		1.42	42	1067	3994	1812	5	H	
2.19		1.67	48	1219	4287	1945	5	M	
POWER with ESCO multi-pin grabber only		1.08	0.83	30	762	3461	1570	4	H
		1.35	1.03	36	914	3688	1673	4	H
	1.62	1.24	42	1067	3860	1751	5	H	
	1.90	1.45	48	1219	4030	1828	5	H	
	2.18	1.67	54	1372	4257	1931	6	M	
	DITCH	2.20	1.68	72	1829	2971	1348	0	H

Approval Code For Arm/Bucket Combinations	
H.....	Heavy material (up to 3,370 lbs./yd ³)
M.....	Medium material (up to 2,700 lbs./yd ³)
L.....	Light material (up to 2,020 lbs./yd ³)
N/A.....	Not applicable

FORESTRY STANDARD & OPTIONAL EQUIPMENT

STANDARD EQUIPMENT

CAB

- LED exterior lights
- Key fob with remote machine light-up functionality; (2) riser step, (3) cab
- SCM air-suspension heated seat, sliding/reclining, adjustable armrests, lumbar support, retractable seat belt, +/- 5 degree tilt
- 4-position tilting consoles with memory position and hydraulic lock-out
- Auto climate control a/c & heat, defrost
- Sirius® Satellite ready sound system w/ AM/FM, MP3 port, USB port, dual speakers & mute button
- Job ticket slot, cup holder, 12-volt accessory outlet, digital clock, 24-volt cigarette lighter, ashtray, dome light, coat hook, high output dual horn, floor mat
- 2-position LED swivel map lights w/ red ambient illumination for safety & night vision compatibility
- High definition LCD monitor w/ full color 7" display
- Anti-theft device
- Single motor dual arm intermittent/continuous windshield wiper w/ washer
- Single pedal travel
- Travel alarm with cancellation switch
- CB radio & antenna mounting provision
- Vandal locks with common key
- On-board diagnostic system
- Rear view camera (full time display)
- RemoteCARE – telematics
- 2-position sun shade

ENGINE

- EPA Tier IV Isuzu diesel engine, no DPF system to maintain
- Three selectable work modes
- 85 amp alternator
- Common rail fuel injection
- Turbocharger with intercooler
- Neutral safety start
- Idle start
- Glow plug pre-heat
- Auto engine warm-up
- Auto idling system
- One-touch idle
- Dual remote fuel filters with water separation
- Double element air filter with in-cab restriction indicator (SE only)
- Remote, full-flow engine oil filter
- Green plug engine oil drain
- EPF Engine Protection
- Emergency engine stop
- Engine oil & hydraulic oil sample ports
- Battery disconnect switch

HYDRAULICS

- Open-center hydraulic system
- Auto swing priority
- Auxiliary hydraulics for open/close/rotate
- Pre-set auxiliary pump settings
- Control levers pre-wired for auxiliary
- Two-speed with auto shift & straight travel
- Attachment cushion valve
- Boom regeneration
- Boom and arm holding valves
- Centralized lube banks

UNDERCARRIAGE

- Sealed and lubricated track chain
- Forestry-style upper roller brackets w/ scrapers
- Planetary drive
- Spring-applied, hydraulic release brake
- 27.5" (700 mm) 2-bar grouser
- Full-length track guards (2 piece, bolt-on)
- HD purpose-built swivel guard belly pan
- HD purpose-built upper belly pans
- HD purpose-built reinforced frame (upper & lower)
- HD purpose-built travel motor covers

UPPERSTRUCTURE

- Rear mounted fuel tank
- HD purpose-built pump & radiator doors
- HD purpose-built tank skin
- HD purpose-built full length catwalks w/ non-skid edge treatment- welded
- HD purpose-built turntable bearing & swing motor
- RH corner guard w/ (2) lights & (2) horns
- Non-skid surface pads
- 14,200 lbs (6 450 kg) Forestry counterweight
- ISO compliant guard and hand rails along upper structure
- Large RH storage box

ATTACHMENT

- HD boom cylinder guard
- Arm cylinder guards (TL)

OPTIONAL EQUIPMENT

CAB

- Oregon OSHA/ROPS/WCB compliant side-entry forestry cab with sky roof and escape hatch
- Rear-Entry certified forestry cab with 48" hydraulic tilting riser
- 1-1/4" front window polycarbonate - *LBX requires 1-1/4" front window polycarbonate for all machines with a processing head installed.*

UNDERCARRIAGE

- 27.5" (700 mm) single-bar grouser
- 27.5" (700 mm) 3-bar grouser

UPPERSTRUCTURE

- "Hockey Stick" guard for RH front corner guard

ATTACHMENT

- Log loader attachment equipped with live-heel (TL)



TELEMATICS WITH NO SUBSCRIPTION FEE

RemoteCARE® lets you remotely monitor and track machine location, operational performance, working status and periodic maintenance requirements - now at no cost to you. It tracks and records both routine and major service intervals for your machines, giving you more flexibility and control when scheduling maintenance procedures. It also lets you be more proactive if potential failure conditions arise; whenever a diagnostic trouble code (DTC) is detected, a warning message appears on the machine display, and an e-mail alert is automatically sent to you. RemoteCARE also assists in theft prevention by offering 24/7 surveillance and geofencing capabilities.

FREE Subscription Includes:

- ✓ 24/7 Remote Monitoring and Security
- ✓ Machine Location
- ✓ Geo-fence & Curfew Range
- ✓ Actual Fuel Consumption
- ✓ Fuel Levels
- ✓ Hour Meter Reading
- ✓ Radiator Water Temperature
- ✓ Machine Working Time/Idle Time
- ✓ Attachment Working Hours
- ✓ Working Modes
- ✓ Service Maintenance Reminders
- ✓ Service Warnings

REMOTECARE® APP

Manage your Link-Belt equipment with this user friendly telematics management tool with GPS technology. The RemoteCARE App provides timely and reliable machine utilization.

App features include...

- Machine location
- Fuel efficiency
- DTC notification history
- Fuel consumption
- Analytical snapshots
- Favorite list
- Utilization report
- Idle rate

Download Apple or Android app at lbxco.com/apps for phone & tablet.

4640 FORESTRY EQUIPMENT

Timber Loaders • Road Builders



Timber Loaders

We've earned our reputation for building strong and dependable log loaders for use in the woods or millyards. Our loaders can be equipped with Fixed or Live-Heel booms to handle large diameter logs and tree-length loads. Or choose from a variety of Butt-N-Top grapple options to match your needs perfectly.



Road Builders

For tasks such as pioneering, construction and maintenance of access roads and right-of-way logging, we've got the right machines for the job. Our road builders are built to move boulders, dig trenches or clear debris with ease.

ROCK-SOLID WARRANTY COVERAGE

All 40 Series machines are backed by a 3-year/3,000 hour Full Machine Warranty*, 2-year/3,000 hour Engine Warranty (2,000 hrs engine electrical parts), 3-year/5,000 hour Powertrain Warranty, 3-year/10,000 hour XtraStructure Warranty (exclusions apply: scrap, demolition, material handling, severe or extreme duty applications, non-Link-Belt attachments), 5-year/3,000 hour EPA Emissions Warranty and participation in the LBX Fluids Analysis Program for the duration of the Powertrain warranty. Extended warranty coverage packages are also available. FREE RemoteCARE® telematics.

**Applies to 2018 or newer serialized models only*



OUR DEALERS KNOW THEIR WAY AROUND THE WOODS

A network of Link-Belt Forestry and Excavator dealers across the U.S. and Canada is waiting to serve you. Expect fast and dependable service, backed by 24/7 access to parts.



LBX Company is the proud maker of quality Link-Belt excavators and is located in Lexington, KY.

#LBX2364 Litho in USA 2/18 LBX® and Link-Belt® are registered trademarks. Copyright 2018. All rights reserved. We are constantly improving our products and therefore reserve the right to change designs and specifications.

Link-Belt
FORESTRY
linkbeltforestry.com