

Link-Belt
MATERIAL HANDLING EQUIPMENT

370 Lx
Tier 3

Operating Weight: 105,357 lbs (47 789 kg)

SAE Net Horsepower: 271 HP (202 kW)

Swing Torque: 112,110 ft.-lbs. (152.0 kNm)



LBX
"Different by Design"

Designed for Durability and Performance...

Maximized Operator Comfort

The industry's largest cab provides low noise, climate controlled heat and air conditioning - standard. *Page 3*

Smarter. Faster. Better.

Inte-LX® or *Intelligent LX* is the most advanced technology to date. *Inte-LX*® maximizes the balance between speed, power, and fuel efficiency. *Page 4*

Faster Cycle Times

A smarter more efficient hydraulic system uses dual pump flow, auto power swing and regenerative circuits for increased productivity. *Page 5*

Exceptional Travel Performance

High torque travel motors automatically shift to provide increased tractive effort when operating in difficult ground conditions. *Page 5*

First Electronic Engine Control in a Material Handler

This results in increased responsiveness to the job requirements; faster cycle times, increased fuel efficiency and clean and quiet operation. *Page 6*

Low Ground Pressure and Exceptional Stability

High-wide undercarriage for increased stability incorporates heavy-duty excavator style components. *Page 7*

Long Life Pin and Bushing Design

Chrome pins and grease impregnated bushings at the boom foot connection hold up to the torsional stresses at this key attachment point and reduces the greasing interval. *Page 7*

Reduced Maintenance and Extended Component Life

The Nephron® Filtration system means less wear and tear on the hydraulic components, reducing hydraulic system breakdowns and maintenance costs. *Page 8*

Superior Serviceability

On-board diagnostics with memory and fewer hydraulic oil changes result in superior serviceability. *Page 8*



Operator's Control Station

Large, Low Noise Cab Design

A wide cab design provides expanded leg and elbow room. **Six silicon filled isolation mounts** float the entire cab above the noise and vibration of an already quiet machine, greatly reducing operator fatigue. Large entry door and access width makes entering and exiting the cab a breeze.

Control Panel

Many machine function switches are concentrated in a panel in clear view and easy reach of the operator.

Tilting Console and Sliding Seat

The seat slides independently of the control consoles to assure optimal joystick positions at all times. The joysticks can be tilted to any of three settings, allowing the operator to work in the most comfortable position. The entire platform can then be moved forward or backward for best foot pedal positioning.



Panoramic Visibility

This cab provides more window space than ever. Even the sunroof is large. The operator's "office with a view" has rear and side windows made of LEXAN® MARGUARD™.

Informative LCD Monitor

Large size LCD Monitor displays graphically a wide range of operating information such as; engine temperature, hydraulic oil temperature, fuel level, travel speed, work mode and engine idle. Additional messages include system/machine warnings and service due messages in your choice of English and 13 other languages. Backlit illumination ensures displays are always readable – day and night.



All Weather Visibility

With built-in washer and intermittent speed control, the wiper keeps your windshield clear, whatever the condition outside. The "rise-up" design takes the wiper arm and blade out of the line of sight when its not in use, plus lifts the blade from the cab surface so that it doesn't freeze to the cab in icy weather.

Fresh Air Induction-Type Climate Control

LX provides exceptional heating/cooling capabilities with a climate control system that automatically regulates the temperature for the operator's comfort. Now with 6 vents, LX Series material handlers provide exceptional air circulation for optimum operator comfort. Front-side air outlet and defroster ensure a comfortable operating environment while the open/close type rear window further improves the ventilation.

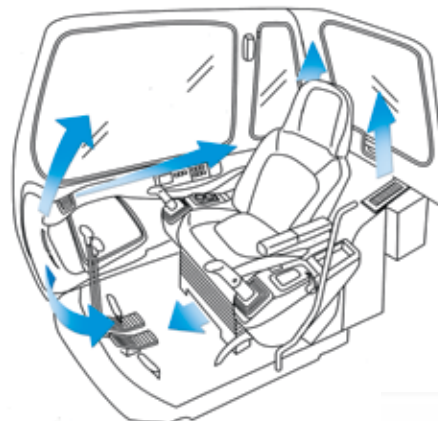

Best Seat at the Site

The KAB 515 seat adjusts to your size and comfort. The semi-bucket seat provides firm support and comfort with armrests, adjustable seat suspension, adjustable lumbar support, and durable urethane cushions.

Tripmeter

In addition to the hour meter, LX has added a Tripmeter. Every job or application can be measured.

AM/FM Stereo Radio

Standard equipment.

Inte-LX®

Inte-LX®, the intelligent computer command control system monitors hydraulic output, pressures, and regulates engine performance for the maximum balance between speed, power and fuel efficiency needed to handle the job.

One-Touch and Auto Idle Control

When user-preset time has elapsed after leaving the control handles in the neutral position, auto-idling automatically drops the engine to idle speed (900 rpm). Or, you can choose to use the one-touch idling switch, located at the top of the right controller so that you are always in control. (Note: Disabled during magnet operation)

Operating Modes

The LX series enables the operator to have a choice on how the machine is operated. Simply choose the work mode that matches the machines output to the job application. Four operating modes are available. (Disabled during magnet operation)



A: Auto-Mode

The most revolutionary approach to maximizing power & fuel efficiency available today. Just select the Auto-Mode with the switch panel. Using actual working pressure readings, Inte-LX® instantly changes modes assuring the best combination of speed and power while you can stay focused on the work at hand.

H: Heavy Mode

For heavy lifting or whenever you need extra power.

S: Standard Mode

For standard lifting and loading operations reducing fuel consumption.

Attachment Mode

Automatically adjusts engine speed and pump output to match additional attachments such as shears. The engine rpm's are presettable to match the hydraulic requirements.

On-Board Diagnostics

An on-board diagnostic system allows service personnel to quickly analyze up to 148 items in four categories:

- **Machine Status:** The diagnostic system provides a detailed view of pump pressure, engine rpm, water temperature, oil temperature, fuel temperature, throttle setting and ongoing operating functions such as auto power-up and auto-mode.
- **Troubleshooting:** Service personnel can trace electrical faults such as sensor failures and harness damage.
- **History:** An on-going record of machine faults is stored in the computer including the hour meter reading at time of the fault to assist in the diagnostics procedure.
- **Systems Configuration:** Service personnel can change machine operating characteristics such as; time delay for auto-idle, language selection, and engine rpm preset for allied attachment mode.

Performance

Advanced Hydraulic System

Top-of-the-Class Cycle Times/Fuel Efficient

The LX Series hydraulic system efficiently delivers power, speed and control when and where it's needed. Fuel consumption and cycle times are more efficient in swing/dump operations over conventional models. This is accomplished through reducing system pressure loss, re-using return oil and providing double pump flow during key operations.

Two Hydraulic Return Lines

Two hydraulic returns lines mean faster speed in the system, and reduces back pressure build-up.

2 Speed Boom and Arm

The 2-speed boom lifting and arm opening and closing function provides the LX series with top-of-its-class lifting speed especially in multi-function operations such as truck or barge loading.

Cushioned Swing

This built-in special cushion valve greatly reduces the shock and vibration at the end of each swing cycle, especially important for grapple and magnet operations.

Cushioned Attachment Control

In addition to having cushioned cylinders, selectable cushioned attachment control lets you smooth out the attachment movements. A cushion valve in the boom and arm circuits reduce shock loading and vibration during attachment operation.

Free Swing

Allows the operator to disengage the swing brake providing crane-like precision and control when handling loads.

Single Pedal Travel

Allows the operator to engage both tracks at the same time using only one pedal. This keeps the machine in line and provides safety and ease in loading/unloading the machine for transport.

Automatic Speed Shifting

When operating in difficult travel conditions, the travel motor automatically downshifts from high to low speed for increased tractive effort and then automatically returns to high speed when travel conditions permit.

Fuel Tank Capacity

The LX Series fuel tank provides the capacity to reduce refueling frequency, allowing for an extended work day.



Generator Package

20 KW Baldor generator. Hydraulic driven generator includes Hubbell automatic discharge magnet controller.

Meter Package

Located in the operators cab, the voltmeter advises the operator of generator output.



Elevated Cab

Operators cab with guarding is available in 6' 0" (1.83 m), 8' 0" (2.44 m) or 10' 0" (3.05 m) elevated heights. All elevated cabs manually tilt for maximum serviceability and transferability. Includes extra wide catwalks. (Hydraulically operated tilting cab optional).



Dependable Isuzu Power



First In Class

The 370 LX is the first material handler in its class to utilize an electronic engine control function. By optimizing the level of fuel injection to match the load, this responsive new system assures more efficient use of fuel, plus by keeping the engine closer to the target engine speed, less lugging takes place so cycle times are faster, exhaust noise, vibration, and smoke are reduced making the environment in the cab and around the machine cleaner and quieter.

Electronic Engine Control (EEC)

Inte-LX[®] maintains engine rpm's when load demands change. Engines equipped with mechanical governors spike rpm's up-and-down when operating loads increase and decrease. This phenomena causes engines to consume extra fuel and be louder.

Cleaner Emissions

Isuzu Tier 3 engines incorporate exhaust gas recirculation technology and fuel cooling to help reduce noxious emissions for a cleaner environment.

Tier 3 Compliant

LX engines meet EPA standards requirements.

Idle Start

At start-up, the engine defaults to idle regardless of throttle position. This prevents over revving a cold engine, helping to extend its service life.

Low Idle Up

When low temperatures or other conditions reduce engine rpm to a point that alternator output won't keep the battery charged, Inte-LX[®] automatically increases the idle speed from 900 to 1100 rpm keeping the batteries fully charged.

Auto Engine Warm-Up

If the engine temperature is low following start-up, the auto warm-up system will operate automatically and continue with engine speed increasing gradually until normal engine operating temperatures are reached.

Air Filtration

LX Series engines are equipped with a dual element air filter with an evacuator cup, a restriction indicator and ground level serviceability for ease of maintenance.

Bell-Mouth Type Fan Housing

Since the bell-mouth shaped fan housing is secured to the engine, there is less clearance

between the fan and the fan housing, assuring a smoother air flow with reduced noise and increased cooling capability.

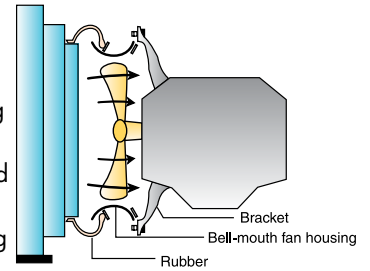

Larger Muffler

The LX series features a larger muffler which absorbs more sound and makes this the quietest Link-Belt yet.

Emergency Engine Shutdown

In emergency situations, the engine can be shut down with the push of a switch located on the control panel in the cab. This switch must be re-engaged prior to restarting the engine.

Engine Product Support

You're never far from having your Isuzu engine serviced because all Link-Belt dealers are authorized Isuzu repair centers with factory-trained personnel. Isuzu parts are stocked in centrally-located Lexington, KY to ensure the fastest delivery time possible.

Advantages of EEC

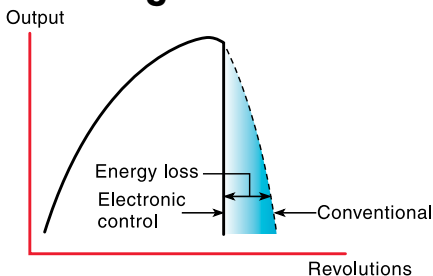

Maintaining engine revolution at a fixed rate regardless of the load prevents the energy loss that occurs when shifting cycle times to accommodate higher or lower loads.

Low Fuel Consumption

The electronic governor responds to changes in operating loads quicker than a mechanical governor. As a result, EEC regulates the amount of fuel injection accurately and quickly.

Lower, Cleaner Emissions

Low fuel consumption results in high ignition efficiency (cleaner emission) and low emissions.

Low Sound Levels

At high idle, EEC can control engine speed at rated horsepower. This means the engine doesn't overrun, resulting in lower sound levels.

Low Vibration

EEC causes engine rpm to be stable, resulting in low vibration.

Upper and Attachments

Improved Pin and Bushing Life

The chrome plated boom foot pin mounted in grease impregnated brass bushing provides a durable and long lasting connection to the attachment. This also makes it possible to extend the lubrication interval on this pin to once every 6 months or 1,000 hours of operation, whichever comes first.

- A. The surface of the bushing is stratified with a solid lubricant in hard brass to protect the parts from abrasion.
- B. The pin's surface is plate-processed to increase hardness and protect from abrasion
- C. The original dust seal is double-structured to keep out dust and dirt and protect from subsequent abrasion.



Undercarriage

High-Wide Undercarriage

High-wide undercarriages incorporate heavy duty components and improve stability. The purpose built material handler car-body is integrally welded for maximum strength and durability.

Bearing Tub

Built into the material handler carbody is the turntable bearing "tub" which extends down through the top plate and is welded to the bottom of the carbody as well as the top for increased strength and durability.

Two-Speed Travel Motor

Combined with high torque final drives to provide increased torque for tough work conditions.



Strut Type Chain Links

There are no weak links in our chain. Struts reduce twisting and hold up to severe point loading when all of the machine weight is transferred through one roller.

Track Rollers

Filled with synthetic oil to reduce heat build up and for long term reliability.

Track Adjustment

Adjustments are made easy with standard grease cylinder track adjusters and shock absorbing springs.

Single Pedal Travel

Allows the operator to engage both tracks at the same time using only one pedal. This feature provides consistent straight-line travel for narrow work environments.

Oversized Turntable Bearings

Designed for heavy loads and high duty cycle operations.

Heavy Duty Swing Motor

Provides increased swing torque for material handling applications.



Reliability/Serviceability

Nephron® Filtration Extends the Service Life of the Hydraulic System

The Nephron® Filtration System eliminates contaminants of 1 micron or more in size. This significantly reduces hydraulic system breakdown and maintenance costs under normal usage. Less wear and tear on the hydraulic components means more years of reliable performance.

Nephron® Filter Advantages

1. Problems associated with hydraulic system contamination are substantially reduced. Machine down time and costs for repairing are saved as a consequence.
2. The interval of hydraulic oil replacement is extended to every 5000 hours.
3. The wear of hydraulic components is reduced, which lengthens the service life of the machine.

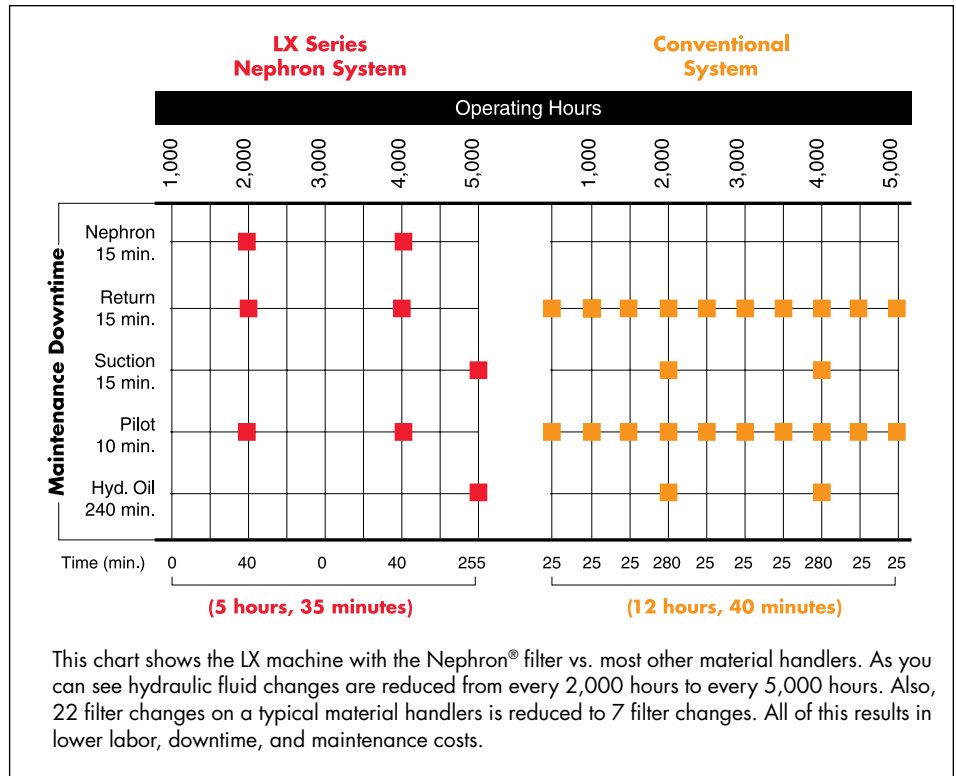
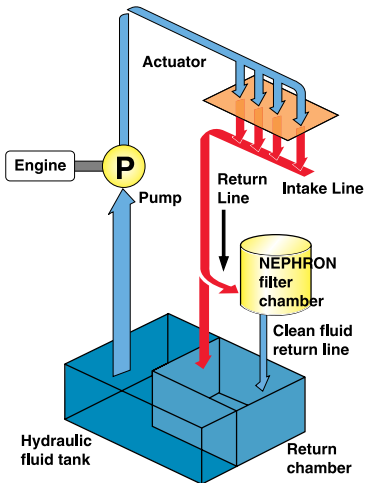

Inte-LX® On-Board Diagnostics

Inte-LX® monitors, stores, and displays information about the electrical and hydraulic systems such as; the current machine conditions, diagnostic warnings, history, and machine default settings. Information stored in Inte-LX® can also be downloaded to your personal computer using standard connectors.

Large wide opening access doors

These doors make it easy to get to all routine maintenance locations.

Hydraulic Fittings

"O" ring seals are used as hydraulic connectors to assure tighter seals.

Air Conditioner Air Intake Filter

This filter lets in fresh clean air and is mounted on the outside of the cab, enabling easy cleaning and replacement.

Sealed Automotive Style Wiring Harness

These harnesses are sealed to eliminate dirt and moisture that can cause a circuit to short out. Wiring is also color and number coded to make trouble shooting faster and easier.

Exceptional Customer/Product Support

Your investment in the Link-Belt LX Series Excavator is always protected. LBX dealers are located from coast to coast; you're never far from quality service professionals. "Level Two" support takes the form of experienced factory service advisors, on-call at a moment's notice. You can be assured that we have the parts when you need them.

Specifications

Engine

Isuzu AH-6HK1XYSS Electric engine control, water cooled, 4-cycle diesel, 6 cylinder, turbocharged with intercooler, 475 CID (7 790 cc), 4.53" (115 mm) bore x 4.92" (125 mm) stroke. EPA Tier 3 compliant.

SAE net horsepower..... 271 HP (202 kW) @ 2,000 rpm
Maximum torque.....797 ft.-lbs. (1080 N-m) @ 1,500 rpm
Starter..... Electric, 24V
Alternator..... 50 amp
Battery 128 amp hours
Air cleaner Double element
Governor Electronic

Hydraulic System

Two variable displacement axial piston pumps and one gear pump for pilot controls, with Link-Belt Inte-LX® Control System. Link-Belt Inte-LX® Control includes: electric engine control, four selectable working modes, auto/one touch idling, automatic speed shifting, free swing, cushioned attachment, and two safety lockout switches including gate lock.

Hydraulic Pumps

Two variable volume piston pumps provide power for attachment, swing and travel. Auxiliary pump for grapple rotate.

Maximum flow..... 2 x 75 gpm (2 x 284 l/min)
Pilot pump max. flow 8.1 gpm (30 l/min)
Aux. pump max. flow 10.9 gpm (41 l/min)

Relief Valve Settings

Attachment 4,970 psi (350 kg/cm²)
Swing circuit..... 4,260 psi (300 kg/cm²)
Travel 4,970 psi (350 kg/cm²)

Hydraulic Cylinders

Young 2-Piece

(number of cylinders - Bore, Rod, Stroke)

Boom..... 2 - 6.5" x 4.5" x 55"
(165 mm x 114 mm x 1 397 mm)
Stick..... 1 - 6.5" x 4.5" x 66"
(165 mm x 114 mm x 1 676 mm)

Young 3-Piece

(number of cylinders - Bore, Rod, Stroke)

Boom 2 - 6.5" x 4.5" x 55"
(165 mm x 114 mm x 1 397 mm)
Stick..... 1 - 6.5" x 4.5" x 66"
(165 mm x 114 mm x 1 676 mm)
Jib 1 - 6" x 4" x 36"
(152 mm x 102 mm x 914 mm)

Oil Filtration

Nephron® filter..... 1 micron
Return, pilot..... 10 micron
Suction filter..... 105 micron

Control Valve One 4-spool valve and one 5-spool valve with auxiliary spool.

Cab and Controls

Cab mounted on 6 fluid filled mountings. Features include a safety glass front window and LEXAN® MARGARD™ rear and side windows, reclining/sliding suspension seat with headrest, armrests, lumbar support, heater, air conditioner, AM/FM stereo, cigarette lighter, pop-up skylight window, and intermittent wiper with washer. Front window slides upward for storage and the lower front window is removable. Control levers are located in 3-position tilting control consoles. Reliable soft-touch switches. Easy-to-read illuminated LCD service monitor keeps operator in touch with critical machine functions.

Heater output..... 20,120 BTU/hr (5 070 kcal/hr)
A/C output..... 18,250 BTU/hr (4 600 kcal/hr)

Swing

Planetary reduction powered by axial piston motor. Internal ring gear with grease cavity for swing pinion. Swing bearing is single-row shear type ball bearing. Swing cushion valve and dual stage relief valves for smooth swing deceleration and stops. Mechanical disc swing brake. Auto power swing.

Swing speed..... 0 - 8.1 rpm
Tail swing 11' 7" (3.52 m)
Swing torque 112,110 ft.-lbs. (152.0 kNm)

Undercarriage

Heavy duty lower X-style carbody is integrally welded for strength and durability. Grease cylinder track adjusters with shock absorbing springs. LC undercarriage with sealed track, lubricated rollers and idlers. Three-bar grouser track shoes.

Carrier rollers 2 per side
Track rollers 9 per side
Track link pitch 9" (228.6 mm)
Shoes 50 per side
Shoe width 29.5" (750 mm)

Travel System

Two-speed independent hydrostatic travel with compact axial piston motors for increased performance. Hydraulic motor powered output shaft coupled to a planetary reduction unit and track sprocket. All hydraulic components mounted within the width of side frame.

Automatic Downshift: When operating in difficult travel conditions, the travel motor automatically downshifts from high to low speed for increased tractive effort and then automatically returns to high speed when travel conditions permit.

Max. travel speed 1.6/2.6 mph (2.5/4.2 km/h)
Traction force..... 82,731 lbs. (37 526 kg)
Gradeability 70%

Spring applied, hydraulically released disc parking brake built into each motor. Each travel motor equipped with counterbalance valve to prevent overspeeding down an incline and 3-stage reliefs for smooth starts and stops.

Attachment Options

Young 48' (14.63 m) 3-piece attachment
Young 50' (15.24 m) 2-piece attachment

Lubricant and Coolant Capacity

Hydraulic tank 46 gal. (175 liters)
Hydraulic system 92 gal. (350 liters)
Final drive (per side)..... 4.0 gal. (15 liters)
Swing drive 2.8 gal. (10.5 liters)
Engine..... 10 gal. (38 liters)
Fuel tank..... 153 gal. (580 liters)
Cooling system..... 7.9 gal. (30 liters)

Operating Weight

Working weight with 29.5" (750 mm) shoes, 48' 3-piece attachment, 6' cab riser, generator and 41 50 lb. (1 885 kg) 57" deep field magnet 105,357 lbs. (47 789 kg)

Working weight with 29.5" (750 mm) shoes, 50' 2-piece attachment, 6' cab riser, generator and 41 50 lb. (1 885 kg) 57" deep field magnet 104,407 lbs. (47 358 kg)

Specifications (continued)

Working Ranges

370 Material Handler Working Range
with a 50' (15.24 m) 2-piece attachment

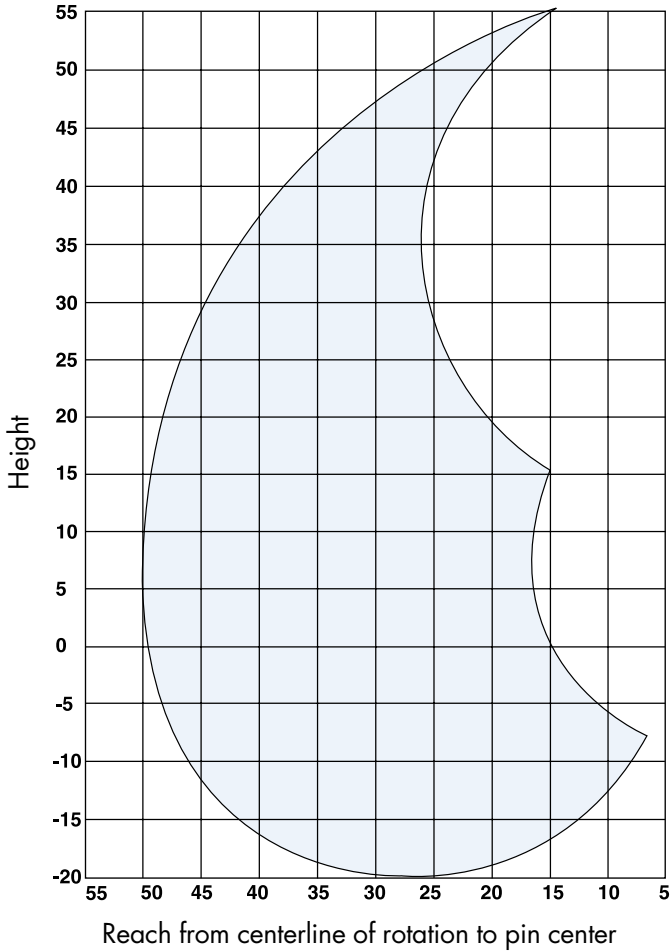

370 Material Handler Working Range
with a 48' (14.63 m) 3-piece attachment

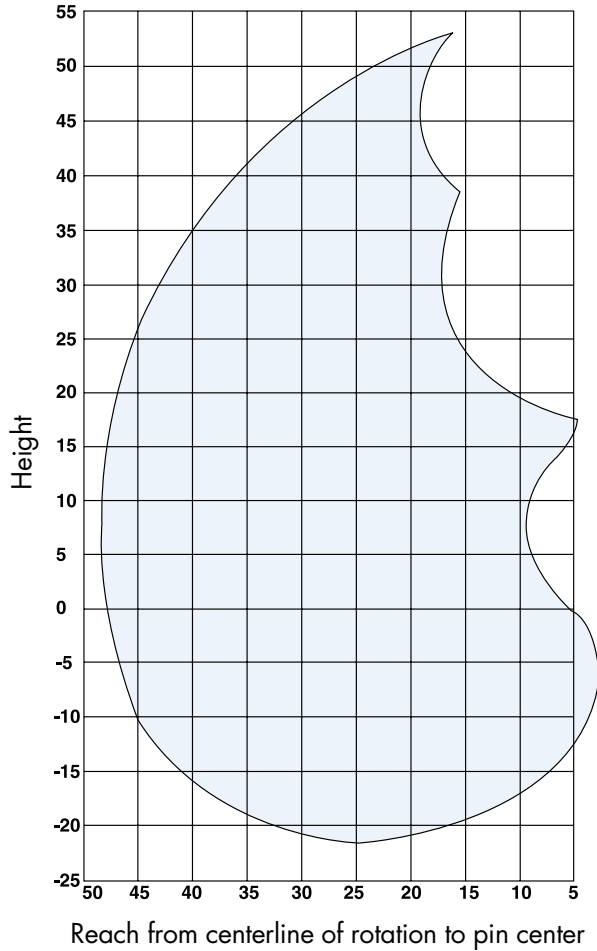

Travel Dimensions

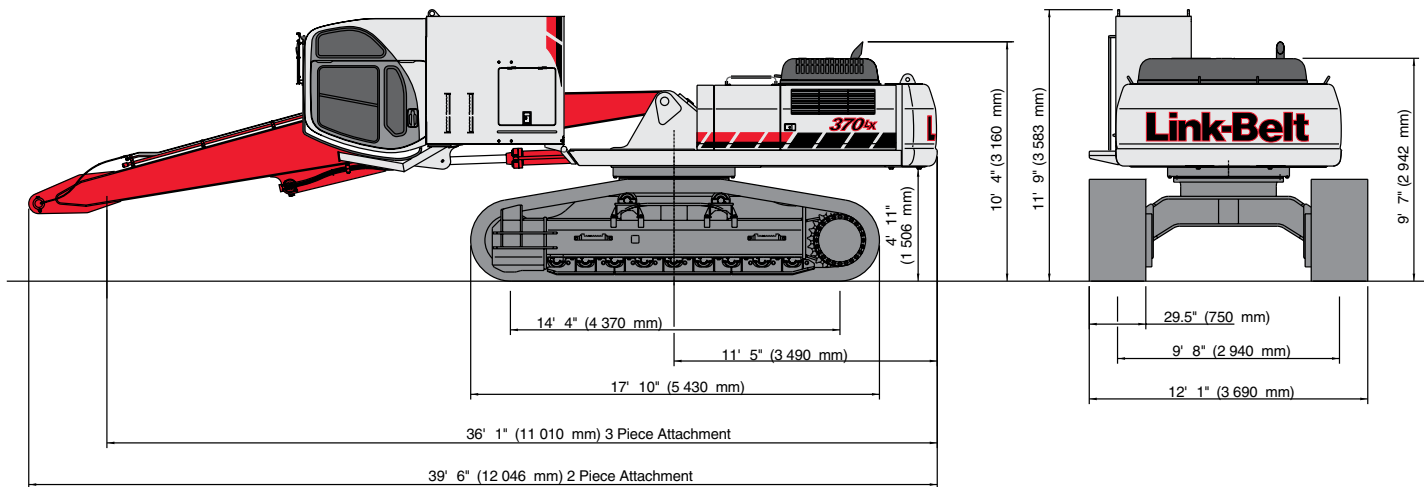

Lifting Capacities

370 LX Material Handler w/two piece Young Attachment

Grapple Pin Height		Radius of Load															
		15' 0" (4.57 m)		20' 0" (6.10 m)		25' 0" (7.62 m)		30' 0" (9.14 m)		35' 0" (10.67 m)		40' 0" (12.19 m)		45' 0" (13.72 m)		50' 0" (15.24 m)	
		End	Side	End	Side	End	Side	End	Side	End	Side	End	Side	End	Side	End	Side
50' 0" (15.24 m)	lbs. kg					16,100* 7 300*	16,100* 7 300*										
45' 0" (13.72 m)	lbs. kg					18,000* 8 160*	18,000* 8 160*	15,500* 7 030*	15,500* 7 030*								
40' 0" (12.19 m)	lbs. kg							17,200* 7 800*	17,200* 7 800*	14,600* 6 620*	14,600* 6 620*						
35' 0" (10.67 m)	lbs. kg							18,000* 8 160*	18,000* 8 160*	16,500* 7 480*	14,900* 6 750	13,000* 5 890*	11,600* 5 260				
30' 0" (9.14 m)	lbs. kg							18,700* 8 480*	18,700* 8 480*	17,800* 8 070*	14,800* 6 710	15,400* 6 980*	11,700* 5 300				
25' 0" (7.62 m)	lbs. kg					18,900* 8 570*	18,900* 8 570*	19,700* 8 930*	18,800* 8 520	19,100* 8 660*	14,600* 6 620	16,800* 7 620	11,600* 5 260	12,800* 5 800*	9,300* 4 210		
20' 0" (6.10 m)	lbs. kg					20,400* 9 250*	20,400* 9 250*	21,600* 9 790*	18,200* 8 250	19,500* 8 840*	14,200* 6 440	16,600* 7 520	11,300* 5 120	13,600* 6 160	9,200* 4 170		
15' 0" (4.57 m)	lbs. kg			20,900* 9 480*	20,900* 9 480*	24,400* 11 060*	23,100* 10 470	22,700* 10 290*	17,400* 7 890	19,900* 9 020*	13,700* 6 210	16,200* 7 340	11,000* 4 980	13,400* 6 070	9,000* 4 080		
10' 0" (3.05 m)	lbs. kg			34,600* 15 690*	30,200* 13 690	28,000* 12 700*	21,700* 9 840	23,600* 10 700*	16,500* 7 480	19,400* 8 790	13,100* 5 940	15,800* 7 160	10,600* 4 800	13,200* 5 980	8,800* 3 990	9,600* 4 350*	7,300* 3 310
5' 0" (1.52 m)	lbs. kg			36,700* 16 640*	27,800* 12 600	29,100* 13 190*	20,300* 9 200	23,500* 10 650	15,700* 7 120	18,800* 8 520	12,500* 5 660	15,400* 6 980	10,300* 4 670	12,900* 5 850	8,600* 3 900	9,700* 4 390*	7,200* 3 260
0' 0" (0 m)	lbs. kg			37,000* 16 780*	25,900* 11 740	29,200* 13 240*	19,100* 8 660	22,700* 10 290	14,900* 6 750	18,200* 8 250	12,000* 5 440	15,100* 6 840	9,900* 4 490	12,700* 5 760	8,400* 3 810		
-5' 0" (-1.52 m)	lbs. kg	10,200* 4 620*	10,200* 4 620*	27,700* 12 560*	24,700* 11 200	28,100* 12 740*	18,300* 8 300	22,100* 10 020	14,300* 6 480	17,800* 8 070	11,600* 5 260	14,800* 6 710	9,700* 4 390	12,600* 5 710*	8,200* 3 710		
-10' 0" (-3.05 m)	lbs. kg	12,300* 5 570*	12,300* 5 570*	25,700* 11 650*	24,100* 10 930	25,700* 11 650*	17,800* 8 070	21,100* 9 570*	13,900* 6 300	17,400* 7 890*	11,400* 5 170	14,000* 6 350*	9,500* 4 300	10,200* 4 620*	8,200* 3 710		
-15' 0" (-4.57 m)	lbs. kg	15,100* 6 840*	15,100* 6 840*	26,400* 11 970*	23,900* 10 840	21,900* 9 930*	17,600* 7 980	21,900* 9 930*	13,800* 6 250	14,500* 6 570*	11,300* 5 120	11,000* 4 980*	9,500* 4 300				

370 LX Material Handler w/three piece Young Attachment

Grapple Pin Height		Radius of Load															
		10' 0" (3.05 m)		15' 0" (4.57 m)		20' 0" (6.01 m)		25' 0" (7.62 m)		30' 0" (9.14 m)		35' 0" (10.67 m)		40' 0" (12.19 m)		45' 0" (13.72 m)	
		End	Side	End	Side	End	Side	End	Side	End	Side	End	Side	End	Side	End	Side
50' 0" (15.24 m)	lbs. kg					16,900* 7 660*	16,900* 7 660*										
45' 0" (13.72 m)	lbs. kg					15,000* 6 800*	15,000* 6 800*	15,900* 7 210*	15,900* 7 210*	11,700* 5 300*	11,700* 5 300*						
40' 0" (12.19 m)	lbs. kg					16,600* 7 520*	16,600* 7 520*	16,100* 7 300*	16,100* 7 300*	14,900* 6 750*	14,900* 6 750*	10,800* 4 890*	10,800* 4 890*				
35' 0" (10.67 m)	lbs. kg					19,700* 8 930*	19,700* 8 930*	17,200* 7 800*	17,200* 7 800*	16,000* 7 250*	16,000* 7 250*	13,900* 6 300*	13,900* 6 300*				
30' 0" (9.14 m)	lbs. kg					25,500* 11 560*	25,500* 11 560*	19,500* 8 840*	19,500* 8 840*	16,800* 7 620*	16,800* 7 620*	15,400* 6 980*	14,400* 6 530	12,200* 5 530*	11,200* 5 080		
25' 0" (7.62 m)	lbs. kg					30,600* 13 880*	30,600* 13 880*	25,700* 11 650*	21,500* 9 750	18,800* 8 520*	17,400* 7 890	16,600* 7 520*	14,300* 6 480	14,100* 6 390*	11,200* 5 080		
20' 0" (6.10 m)	lbs. kg			27,400* 12 420*	27,400* 12 420*	31,000* 14 060*	31,000* 14 060*	26,700* 12 110*	21,200* 9 610	22,800* 10 340*	15,800* 7 160	18,100* 8 210*	13,800* 6 250	15,700* 7 120*	11,000* 4 980	10,900* 4 940*	8,700* 3 940
15' 0" (4.57 m)	lbs. kg	19,600* 8 890*	19,600* 8 890*	36,200* 16 420*	36,200* 16 420*	32,200* 14 600*	30,200* 13 690	27,200* 12 330*	20,700* 9 380	23,000* 10 430	15,100* 6 840	18,800* 8 520	12,500* 5 660	15,900* 7 210	10,700* 4 850	12,600* 5 710*	8,600* 3 900
10' 0" (3.05 m)	lbs. kg	21,000* 9 520*	21,000* 9 520*	42,100* 19 090*	42,100* 19 090*	33,900* 15 370*	29,200* 13 240	27,900* 12 650*	20,100* 9 110	22,700* 10 290	14,800* 6 710	18,500* 8 390	12,200* 5 530	15,600* 7 070	10,400* 4 710	12,800* 5 800	8,400* 3 810
5' 0" (1.52 m)	lbs. kg	14,600* 6 620*	14,600* 6 620*	43,400* 19 680*	43,400* 19 680*	35,600* 16 140*	28,100* 12 740	28,500* 12 920*	19,400* 8 790	23,000* 10 430	15,200* 6 890	18,800* 8 520	12,500* 5 660	15,300* 6 940	10,100* 4 580	12,600* 5 710	8,200* 3 710
0' 0" (0 m)	lbs. kg	11,400* 5 170*	11,400* 5 170*	27,600* 12 510*	27,600* 12 510*	36,800* 16 690*	27,500* 12 470	29,000* 13 150*	19,700* 8 930	23,100* 10 470	15,200* 6 890	18,300* 8 300	12,000* 5 440	14,900* 6 750	9,700* 4 390	12,400* 5 620	8,100* 3 670
-5' 0" (-1.52 m)	lbs. kg	13,800* 6 250*	13,800* 6 250*	21,000* 9 520*	21,000* 9 520*	36,800* 16 690*	25,900* 11 740	28,800* 13 060*	18,800* 8 520	22,300* 10 110	14,500* 6 570	17,800* 8 070	11,600* 5 260	14,600* 6 620*	9,500* 4 300	11,700* 5 300*	7,900* 3 580
-10' 0" (-3.05 m)	lbs. kg	13,800* 6 250*	13,800* 6 250*	18,000* 8 160*	18,000* 8 160*	28,300* 12 830*	24,900* 11 290	27,100* 12 290*	18,200* 8 250	21,700* 9 840*	14,000* 6 350	17,500* 7 930	11,300* 5 120	13,600* 6 160*	9,300* 4 210		
-15' 0" (-4.57 m)	lbs. kg	13,900* 6 300*	13,900* 6 300*	17,300* 7 840*	17,300* 7 840*	25,800* 11 700*	24,500* 11 110	23,700* 10 750*	17,800* 8 070	18,800* 8 520*	13,800* 6 250	14,600* 6 620*	11,200* 5 080	10,100* 4 580*	9,300* 4 210		
-20' 0" (-6.10 m)	lbs. kg					22,900* 10 380*	22,900* 10 380*	18,300* 8 300*	17,800* 8 070	14,100* 6 390*	13,800* 6 250						

Notes: Material Handler lifting capacities

- Lifting capacities shown should not be exceeded. Weight of all lifting accessories must be deducted from the above lifting capacities.
- Lifting capacities are in compliance with ASME B30.25 SCRAP AND MATERIAL HANDLERS
- Lifting capacities are based on machine standing on firm, uniform supporting surface. User must make allowances for job conditions such as soft or uneven ground, sudden stopping of loads, or other unfavorable job conditions.
- Lifting capacities shown do not exceed 75% of minimum tipping loads or 87% of hydraulic capacities. Capacities marked with an asterisk (*) are limited by hydraulic capacities.
- These capacities apply to machines having 4970 psi boom hoist cylinder pressure.
- Least stable position is over the side.
- Operator should be fully acquainted with the Operator's Manual & Operating Safety Booklet, furnished by the manufacturers before operating the machine.
- Capacities apply only to the machine as originally manufactured and normally equipped by LBX Company LLC.

Specifications (continued)

Standard Equipment

- Inte-LX® Computer System
- Self-diagnostic system
- Four selectable working modes
- One-touch decelerator (grapple only)
- Auto idling system
- Auto idle start
- Low idle up
- Auto engine warm up
- Cushioned attachment control
- Free swing control
- Travel alarm
- Nephron® filtration system
- Low noise/low vibration cab floating on 6 fluid filled mounts
- Sliding/reclining, suspension cloth upholstered seat with adjustable arm rests and lumbar support, retracting seat belt
- 3-position tilting consoles
- 4th position on left console for entering and exiting the cab also serves as control lock-out
- Illuminated LCD service monitor
- Climate control heater and air conditioner
- Horn, interior lighting, AM/FM STEREO radio, digital clock, floor mat, cigarette lighter
- Safety glass front windows with automatic lock and intermittent rise-up windshield wiper and washer, large LEXAN® rear/side windows
- Gate lock and gate lock lever (control lock-out device)
- Common key for cab & house doors, engine hood, tool box, and fuel cap
- Hand grab rails both sides
- Rear view mirror, coat hook, storage compartment
- Heavy duty lower carbody
- Chrome plated boom foot pin with oil impregnated bushing
- Grapple open/close rotate system
- 18,550 lbs. (8 415 kg) counterweight
- 12 volt adapter
- Single pedal travel
- High-wide undercarriage

Options

- 6', 8', or 10' manual tilt cab, includes ladder, catwalk and platform (6' elevated cab most common)
- Hydraulic tilt cabs are available upon request
- 2-Piece 50 ft. Young Attachment
- 3-Piece 48 ft. Young Attachment
- 20 Kw Baldor generator includes voltmeter and ammeter



LBX Company is the proud maker of quality Link-Belt excavators and is located in Lexington, KY.



Litho in USA 6/11 #LBX2190 (supersedes #LBX2146)

© LBX and © Link-Belt are registered trademarks. Copyright 2011. All rights reserved. We are constantly improving our products and therefore reserve the right to change designs and specifications.