

# Competitive Bulletin

October 2001

## Cat® 252 vs. New Holland LS180 Skid Steer Loader



Cat 252



New Holland LS180

For Dealer Sales Personnel



# Table of Contents

---

<b>Machine Specifications</b> .....	<b>3</b>
<b>Performance</b> .....	<b>4</b>
<b>Vertical Lift Performance</b> .....	<b>6</b>
<b>Vertical Lift Linkage</b> .....	<b>7</b>
<b>Vertical Lift Paths</b> .....	<b>9</b>
<b>Drive System</b> .....	<b>10</b>
Engine Performance .....	12
Engine-to-Pump Cooling .....	14
Pumps .....	15
Axle/Wheel Mounting .....	16
Axle Grease Zerks (Grease Points) .....	17
<b>Cooling System</b> .....	<b>18</b>
<b>Coupler/Work Tool Mounting</b> .....	<b>20</b>
<b>Instrumentation</b> .....	<b>21</b>
<b>Loader Controls/Parking Brake</b> .....	<b>23</b>
<b>Serviceability Access to Rear Compartment</b> .....	<b>25</b>
<b>Serviceability</b> .....	<b>27</b>
<b>Key Selling Points vs. New Holland LS180</b> .....	<b>29</b>

# Machine Specifications

Machine Specifications	Caterpillar 252	New Holland LS180
<b>Performance</b>		
Rated Operating Capacity (kg/lb)*	1020/2250	998/2200
ROC with optional counterweight (kg/lb)	1043/2300	1161/2560
Operating Weight (kg/lb)	3454/7615	3262/7193
Breakout Force — Tilt (kg/lb)	2362/5212	2737/6034
Breakout Force — Lift (kg/lb)	2277/5020	1902/4194
Maximum Rimpull (kN/ft-lb)	38,032/8550 <sup>1</sup>	35,770/8041 <sup>1</sup>
<b>Hydraulics</b>		
Actuation	Pilot	Foot Pedals
Hydraulic Flow (lpm/gpm)	83.3/22	70/18.5
Hydraulic Pressure (kPa/psi)	22 759/3300	17 926/2600
Hydraulic Horsepower (kW/hp)	31.6/42.4	21/28.1
XT Hydraulic Hose	Std.	NA
<b>Engine</b>		
Make	Caterpillar	New Holland
Model	3034	332T/J
Horsepower (kW/hp)	44/59	45/60
Displacement (L/in <sup>3</sup> )	3.0/183	3.1/192
Number of Cylinders	4	3
<b>Dimensions</b>		
Length w/std Bucket (mm/in)	3616/142.4	3581/141
Height to Top of Cab (mm/in)	2098/82.2	1956/77
Height to Hinge Pin (mm/in)	3244/127.7	3165/124.6
Wheelbase (mm/in)	1228/48.3	1219/48
Reach (mm/in)	825/32.5 <sup>2</sup>	825/32.5 <sup>2</sup>
Ground Clearance (mm/in)	230/9	203/8
<b>Capacities</b>		
Hydraulic Tank (L/gal)	35/9.2	22.7/6
Fuel Tank (L/gal)	90.1/23.8	68.1/18
<b>Drive Train</b>		
Actuation	Pilot	Mechanical Levers
Axle Lubrication	Permanent	Grease Points (Zerks)
Number of Chains	4	4
Anti-stall System	Yes	No
Recommended Chain Tension Inspection	500 hrs	1000 hrs
Hand and Foot Throttle	Std.	NA
Parking Brake	SAHR, wet-disks	Mechanical

<sup>1</sup> Caterpillar Dynamometer

<sup>2</sup> Measurement taken at 45 degree angle

\* No more than 50 percent of SAE tipping load



- Caterpillar increased rimpull allows the 252 to push more material and get further into piles
- Caterpillar 252 is able to provide extra-hydro-mechanical torque needed to complete the toughest jobs
- Caterpillar exclusive Anti-Stall System allows operators to dig aggressively without stalling the machine — increasing productivity and decreasing component wear
- Taking all five digging criterion into consideration, the Cat 252 proves to have superior performance compared to the New Holland LS180
- Demonstration Techniques to be aware of when competing against the LS180.

## Rimpull

The Caterpillar 252 provides superior performance over the New Holland LS180 with six percent more available power at the wheels (rimpull) compared to the New Holland LS180 (38 kN vs. 35.8 kN [8,550 ft-lb vs. 8,041 ft-lb], taken from Caterpillar Dynamometer tests). This additional power allows the 252 to push more material, get further into piles and pull itself out of holes that the LS180 cannot.

## Hydraulics

The Caterpillar 252 has more hydraulic horsepower (31.6 kW vs. 21 kW [42.4 hp vs. 28.1 hp]) and an exclusive anti-stall feature, which delivers maximum usable torque without stalling the engine. With 50 percent more hydraulic horsepower, the Caterpillar 252 is able to provide the extra hydro-mechanical torque needed to complete the toughest jobs.

## Anti-stall

The exclusive anti-stall feature delivers maximum usable torque at all times without stalling the engine and allows operators to dig aggressively as well as:

- Provides maximum engine horsepower to the drive system
- Automatically controls the pumps to provide peak torque without fatiguing the operator
- More efficient than the LS180 drive system by limiting flow to the hystat relief and reducing heat load in the system

## Breakout Force

The Caterpillar 252 also features 19.6 percent more breakout force for the lift circuit (22.3 kN vs. 18.7 kN [5,020 lb vs. 4,194 lb]) than the LS180. New Holland does have more tilt breakout force (26.9 kN vs. 23.2 kN [6,034 lb vs. 5,212 lb]) than the Caterpillar 252 but that alone does not make the LS180 a better machine. New Holland uses a shorter bucket (76.2 mm [3 in]) compared to the Caterpillar 252 when compiling performance data. Because of this, the LS180's tilt breakout force will appear much higher than it actually is. If they used a similar length bucket (identical to 252), breakout forces would be closer in proximity. There are five significant criterion that must be taken into consideration when assessing a machines digging capability:

- Rimpull
- Breakout Force Tilt
- Breakout Force Lift
- Anti-stall
- Weight

The Caterpillar 252 out-performs the LS180 on all the criteria except breakout force tilt. Furthermore, the LS180 does not offer the exclusive anti-stall feature which increases the possibility of stalling the machine during digging applications. Taking all five criteria into consideration, the Cat 252 will prove to have superior performance compared to the LS180. In addition to better performance, the Caterpillar 252's dual tilt cylinders provide greater cylinder protection, easier machine ingress/egress, superior viewing area to the cutting edge and faster hydraulic cycle times than the New Holland LS180.

## Demonstration "Awareness" Techniques

Though the Caterpillar 252 has superior performance compared to the New Holland LS180, Caterpillar sales personnel need to be aware of the techniques that can be used to make the LS180 look better on a demo. Actual and perceived breakout forces can be two different things. Many factors can affect perceived breakout force, such as: using buckets with short floors, using buckets with lower rated capacities or using the Caterpillar 252's anti-stall system to drive the machine further into the pile to pin the bucket. Foam filled tires along with additional counterweights may be used to give the LS180 a misleading stability advantage. The sales individual needs to be sure the 252 has a similar configuration compared to the LS180 during a demo.



252 cantilevered pin and spherical bearing

# Vertical Lift Performance

---

- **Caterpillar allows for the movement of heavier payloads and increased productivity due to an additional 23 kg (50 lb) rated operating capacity**
- **Caterpillar higher hinge pin height provides additional clearance resulting in faster cycle times and less damage to trucks**
- **Caterpillar superior dump angle of 50 degrees provides superior bucket cleanout and increased productivity**

The Caterpillar 252 and New Holland LS180 have vertical lift linkages allowing them to lift loads in a straight vertical path rather than a radial path giving them the capability to lift material higher and reach farther away from the machine at maximum height. These machines are also built with a longer wheelbase and higher rated operating capacities allowing for increased load carrying capabilities.

## **Payload**

The Cat 252 has a higher rated operating capacity of 23 kg (50 lb) when compared to the LS180 (1020.6 kg vs. 997.9 kg [2,250 lb vs. 2,200 lb]), allowing for heavier load carrying which increases productivity. The wheelbase is virtually the same on both machines with the Cat 252 at 1226.8 mm (48.3 in) and the New Holland LS180 at 1219.2 mm (48 in).

## **Hinge Pin Height**

Caterpillar 252 has a higher hinge pin height than the New Holland LS180 by 78.7 mm (3.1 in) (3243.6 vs. 3164.8 [127.7 in vs. 124.6 in]) that allows for higher placement of material and more clearance over trucks. The reach is identical on both machines at 825.5 mm (32.5 in).

## **Dump Angle**

The LS180 can only achieve a maximum dump angle of 45 degrees, which limits their ability to fully clean out the bucket when dumping sticky material. The Cat 252 has a maximum dump angle of 50 degrees allowing for superior clean out of the bucket and increased productivity.

- Caterpillar has designed a system to provide minimal linkage wear resulting in longer linkage life
- New Holland's linkage is difficult to service and suffers from increased wear
- Caterpillar delivers superior load distribution with the Cat cantilevered pins and spherical bearings
- Cross member supporting loader arms and linkage provides a stiff, stable structure preventing torsional loading resulting in longer life

## 252 Pins and Bearings

The Caterpillar vertical lift linkage is an efficient design resulting in a comparatively lightweight structure given its load carrying capability. Additionally, the loader arms provide the strength needed for long service life without sacrificing operator visibility to the work tool. The lift link connects the loader arm to the upper frame via cantilevered pins. Unlike competitive pins, Cat pins are not tapered. They have the same diameter all the way through and use a flagged end to secure it on one side allowing it to rotate in the corresponding bore. The Cat lift link pin uses a spherical (swivel) bearing where it attaches to the frame to prevent point loading and premature pin wear. The spherical bearing distributes the load from the lift arm into the frame by allowing the pin to not only rotate but pivot as well within the bore thus reducing the chance of developing fatigue cracks in the arms. Traditional flagged pins have been used in all other joints for ease of service and long life. Another advantage of this design is that it allows the machine to endure the punishment of heavy digging with minimal wear to the linkage. Caterpillar with its cantilevered pins and swivel bearings provide a stiff, sturdy linkage while, at the same time, allowing the linkage to flex which distributes the load throughout the frame and prevents pin galling and point loading. This vertical linkage system helps keep the lift arms from getting loose and "slapping".

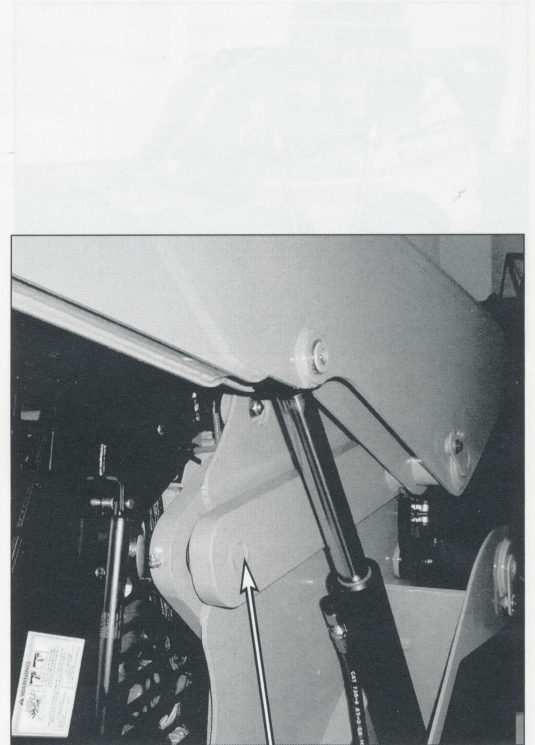

252 cantilevered pin and spherical bearing

## Vertical Lift Linkage



LS180 wear strips

### LS180 Pin Galling and Point Loading

Almost all competitors' cantilevered pins are tapered at the end and have mating tapered bores, allowing the pin to wedge itself into the bore. High-torqued bolts hold the pins in place and are difficult to remove during replacement. The LS180 is no exception, its vertical lift linkage is outfitted exclusively with the tapered, cantilevered style pins. Because of the tapered bore and high-torqued bolts, removing the pins is very difficult which decreases the serviceability of the linkage. The lift linkage is attached to the cab, requiring a tedious 19-step process (approximately two hours) to lift the cab, which severely limits accessibility to lower frame components. Furthermore, since the linkage is attached to the cab, New Holland is relying on the cab to carry approximately 20 percent of the loader forces which is not the most efficient load-bearing structure for a 4-bar linkage. Ideally, all stresses should be routed to the main frame of the machine.

### Cross Member Support

New Holland lacks a cross member that connects the linkage as one. This allows the links to move independently causing the lift arms to get so loose that New Holland has put wear strips on the sides of the frame to protect it from the lift arms. Caterpillar offers a cross member that connects the 252 loader arms, links and frame together via a control link that provides a stiff, stable structure and prevents torsional loading. Coupled with the 252's cantilevered pins and spherical bearing, the need for wear strips is eliminated. New Holland's linkage design is also prone to damage because it sticks out behind and on the sides, making it easy to turn the machine and hit the arms, causing significant damage and costly repairs.

The Caterpillar vertical lift linkage has been designed to be extremely efficient by giving the lift arms stronger sections without sacrificing the size that competitors have. The careful placement of materials in the lift arms allows the operator to have the strength needed with the superior viewing area that is expected from the Caterpillar Skid Steer Loaders.

- Caterpillar delivers maximum usable reach throughout the lift path allowing increased productivity due to increased reach at lower height
- New Holland lift path achieves maximum reach near maximum height, limiting usable reach throughout the lift path
- Caterpillar 236/246 provides more reach up to 2159 mm (85 in) offering a cost effective alternative due to less linkage and wearable parts

## Reach

The Cat 252 has a vertical lift path that gives the operator maximum usable reach throughout the lift cycle. This allows the operator to be more productive as a result of increased reach at lower heights. Once the lift arms are raised from the lowered position, they immediately move outward away from the machine until the hinge pin reaches 1778 mm (70 in), then the arms retract 50.8 mm (2 in) bringing them closer to the machine. This gradual retraction of the lift arms shifts the load's center of gravity towards the machine, making it more controllable.

The lift pattern of the New Holland LS180 limits the amount of reach available throughout its cycle. At a height of 1651 mm (65 in), the LS180 has a reach of 317.5 mm (12.5 in) when measured from the bucket hinge pin. The Caterpillar 252 has a reach of 408.9 mm (16.1 in). The LS180's lift pattern gradually extends outward, causing the machine to have maximum reach towards the very top of its lift cycle. The LS180 does not achieve maximum reach until 2692.4 mm (106 in), compared to the 252, which offers maximum reach at 1778 mm (70 in). By attaining maximum reach earlier in the lift path, the 252 offers considerably more usable reach throughout the lift cycle.

## Cost Effective

If reach at lower heights is the customer's primary concern, the Caterpillar 236 and 246 will have more reach — up to 2159 mm (85 in) when compared to the 252 and LS180. In many cases, the large radial lift machines (236/246) could replace an LS180 giving the customer fewer linkages and wearable parts. When the customer needs extended reach above 2159 mm (85 in) in height and higher load carrying capabilities, then the Caterpillar vertical lift 252 or 262 should be used.

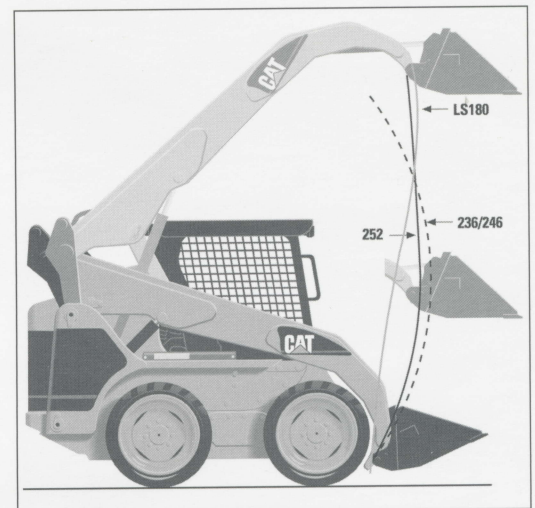

252 and LS180 lift paths

- Caterpillar splined, hystat pumps are more efficient than New Holland's engine-to-pump gearbox that introduces more wearable parts
- Caterpillar transmits power directly from drive motor to sprocket vs. New Holland's drive motor to gearbox to sprockets system, which introduces more wearable parts and adds another service item

## Caterpillar Drive System

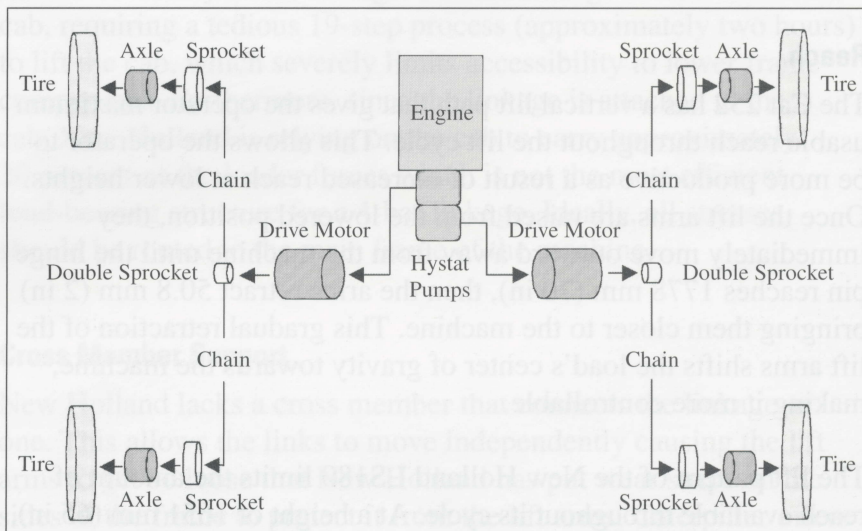

Caterpillar offers the most efficient and effective drive system by eliminating unnecessary components and providing unmatched torque and rimpull. Power originates in the Caterpillar 3034 longitudinally mounted engine. The engine turns two hystat piston pumps enclosed in a single housing. These hystat pumps are directly splined to the engine flywheel providing a coupling system with no efficiency losses due to belts or additional coupling components. The pumps provide hydraulic flow and pressure to two large displacement radial piston motors. These motors convert the fluid energy from the pumps to mechanical energy that drive two chains from a double drive sprocket in a "Bow-Tie" configuration on each side of the frame. Each chain is housed in a separate chain case and is connected to a larger sprocket that drives a short axle, which turns the tire. The drive system offered by Caterpillar reduces the amount of components used providing increased reliability and improved serviceability and accessibility in a very simplistic fashion.

## New Holland Drive System

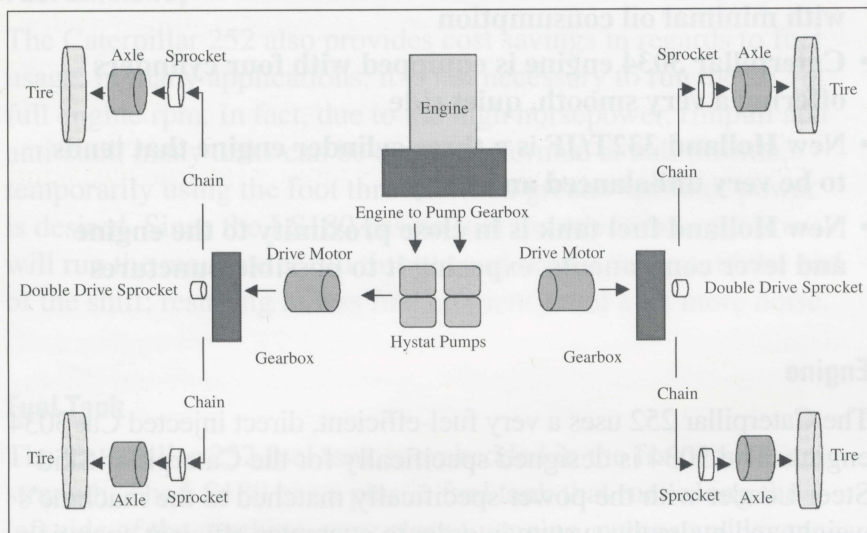

New Holland uses a process similar to Caterpillar, but they added additional, costly steps into the drive system. Power originates in the New Holland 332T/JF engine. An additional engine-to-pump gearbox transfers power from the engine flywheel to two hystat piston pumps. This gearbox style coupling system is very noisy and less efficient compared to the 252 direct coupling system. Hydraulic power is transmitted from the hystat pumps to the hydrostatic motors, which are connected to gearboxes located between the motors and sprockets. Power is then transmitted through gears to a drive sprocket, which in turn drives two chains in a “bow tie” configuration. The two chains turn a larger sprocket that drives an axle, which turns the tires. The extra gearbox has introduced additional wearable parts as well as an additional maintenance item into the drive train. The gearbox must be serviced every 250 hours to ensure the oil level is sufficient. Furthermore, any time parts are added to a system, reliability is decreased.

Both manufacturers use the same #100 high strength, pre-stressed chains to drive their axle sprockets, and they both offer customers the ability to adjust the chains. All chains wear; therefore, drive chain life is significantly reduced when chain tension is not maintained properly.



## Engine Performance

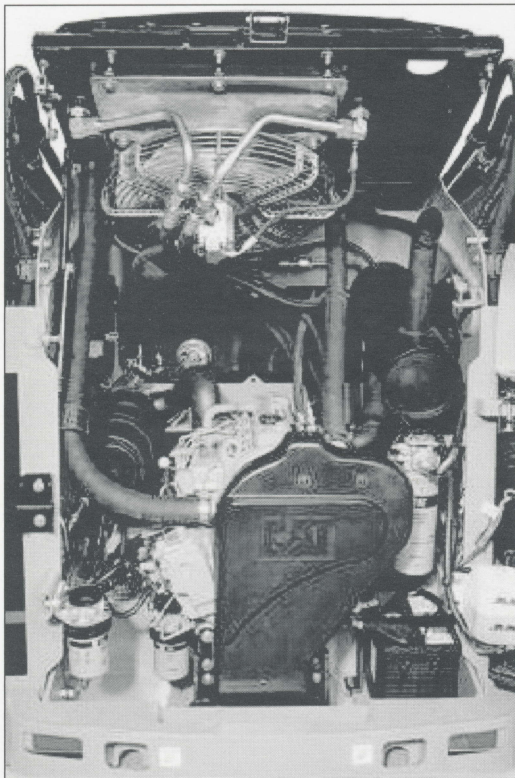

252 engine compartment



LS180 engine compartment

- Caterpillar 3034 engine offers superior fuel-efficiency along with minimal oil consumption
- Caterpillar 3034 engine is equipped with four cylinders offering a very smooth, quiet ride
- New Holland 332T/JF is a three cylinder engine that tends to be very unbalanced and noisy
- New Holland fuel tank is in close proximity to the engine and lever components, exposing it to possible punctures

### Engine

The Caterpillar 252 uses a very fuel-efficient, direct injected Cat 3034 engine. The 3034 is designed specifically for the Caterpillar Skid Steer Loader with the power specifically matched to the machine's weight and hydraulic system in order to guarantee efficient operation. The 3034 engine provides a net horsepower of 44 kW (59 hp), impressive engine torque of 210 N•m (155 ft lb), four cylinders and a displacement of 3.0 L (183.06 in<sup>3</sup>). The 3034 engine also comes complete with an oil analysis port for preventative maintenance, vertically mounted filters to reduce spills and glow plugs for easy starting. Fuel delivery is accomplished by the use of a cassette-type, in-line injection pump and two-stage injectors to provide low emissions that meet all U.S. EPA regulations through 2003.

The New Holland uses a turbo-charged, direct injected, water-cooled New Holland 332T/JF engine. The 332T/JF is a 3.15 L (192.2 in<sup>3</sup>) engine that provides a net horsepower of 44.7 kW (60 hp). The LS180 has been known to consume excessive amounts of engine oil and fuel, which increases owning and operating costs. This excessive consumption is not limited to the LS180, it is true for the entire line of New Holland Skid Steers. The New Holland 332T/JF engine contains three cylinders that tend to vibrate because they are unbalanced, causing the machine to be very noisy and which could pose a reliability problem due to excessive component vibration. The Cat 3034 engine is equipped with four cylinders, offering the operator a smooth, quiet ride. Caterpillar recommends an engine oil change every 500 hours compared to New Holland's 100 hour recommendation. The 3034 extended life coolant (ELC) should be changed every 6,000 hours or four years with yearly replenish. New Holland recommends changing their coolant every year. Caterpillar decreased oil change intervals by 400 percent and coolant interval by 300 percent when compared to New Holland and this leads to decreased maintenance and lower operating costs for Caterpillar owners.

## Fuel Efficiency

The Caterpillar 252 also provides cost savings in regards to fuel usage. In many applications, it is not necessary to run the 252 at full engine rpm. In fact, due to the high horsepower, rimpull and anti-stall, many tasks can be easily performed at half throttle, temporarily using the foot throttle when greater speed or power is desired. Since the LS180 has no foot throttle, most operators will run the machine at full throttle and keep it there until the end of the shift; resulting in less fuel efficiency and a lot more noise.

## Fuel Tank

The Caterpillar 252 fuel tank is embedded in the frame for extra strength. The LS180 has a plastic fuel tank that runs along the left side of the machine, very close to engine, pumps and lever components. Because of close component proximity, the fuel tank is susceptible to heat, abrasion and puncture holes which could lead to leaks.

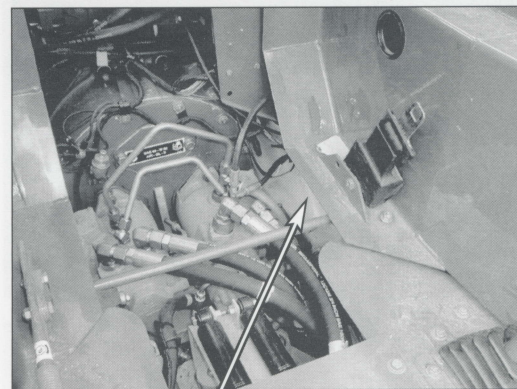

LS180 fuel tank surrounded by components

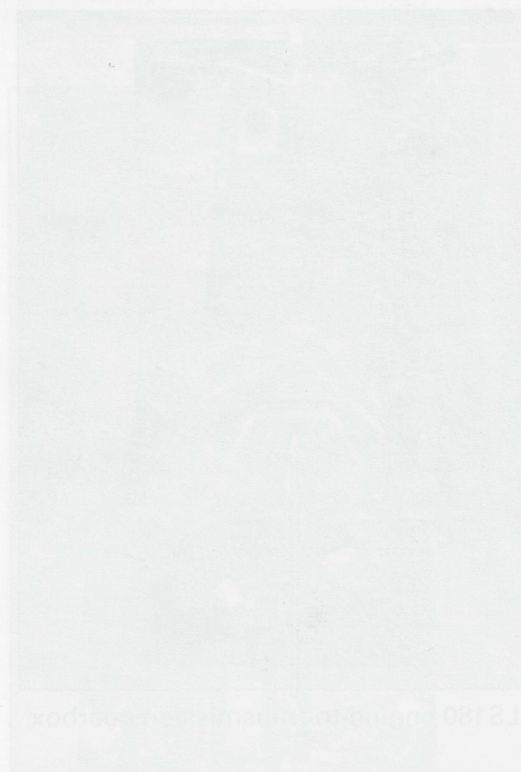

LS180 separate hystat pumps

## Engine-to-Pump Coupling

- Caterpillar 252 features a direct coupling between the hystat pumps and engine, allowing wide-open serviceability
- New Holland LS180 offers an inefficient gearbox coupling connecting the hystat pumps to the engine introducing another service item to the machine

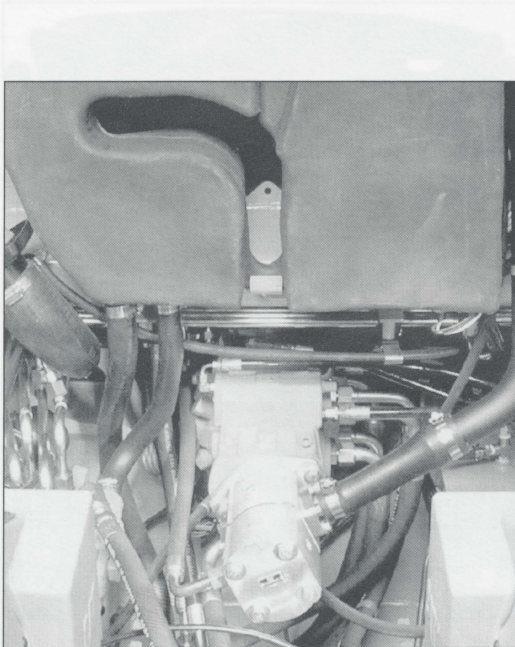

252 engine-to-pump coupling

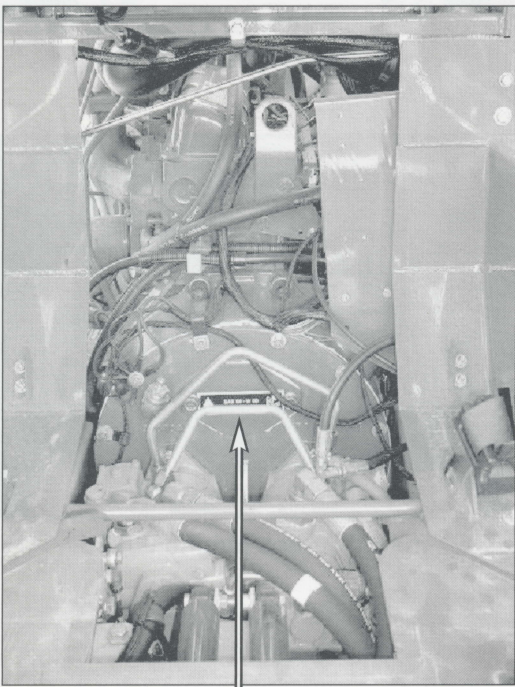

LS180 engine-to-transmission gearbox

### Direct Coupling

The Caterpillar 252 has a direct coupling between the hydrostatic/hydraulic pump line and the in-line mounted Cat 3034 engine. This design takes away the need for gear driven pumps and allows for wide-open serviceability to the hydrostatic and hydraulic pumps. With this design, Caterpillar can closely match engine speed with pump displacement in order to maximize hydraulic performance. Caterpillar also uses a single housing pump, enclosing two variable piston pumps. This compact single housing increases the accessibility to the lower frame and increases the reliability of the pumps by reducing seals and possible leak points. New Holland separates their pumps and in doing so, increases the amount of possible leak points.

### Gearbox Coupling

New Holland uses an engine-to-transmission gearbox to transfer power from the engine to the hydrostatic pumps through an internal gear set (spur gear set). The oil in the gearbox must be checked every 250 hours, adding another maintenance interval for the operator. Additionally, a gearbox style system is not as efficient as a direct coupling system, leading to loss of horsepower to the hydrostatic pumps through an internal gear set (spur gear set). This design introduces more wearable parts into the hydraulic system increasing operating costs, while at the same time, cluttering the main frame and limiting accessibility to other components.

- Caterpillar 252 low effort pilot hydraulics with an anti-stall device “thinks” and “reacts” to its environment without the need for operator input, resulting in increased productivity
- New Holland LS180 mechanical “row boat” levers with operator sensing requires a great deal of operator effort and experience

## Exclusive Pilot Hydraulics

The hystat pumps on the Caterpillar 252 and LS180 are modulated very differently; the 252 is operated by pilot hydraulics whereas mechanical levers operate the LS180. The 252 hystat pumps have no mechanical linkages, are enclosed in a single housing to reduce leak points and automatically de-stroke themselves thanks to a speed-sensing valve located inside the pumps. The pilot hydraulics control a swash plate located inside the pumps that varies the amount of flow (speed) that the pump will produce. When the operator pushes the low effort joystick forward or backwards, low-pressure hydraulic oil is sent to the pumps and moves the swash plate controlling the speed and direction of the machine. When a load is sensed and the engine lugs back, the swash plate is de-stroked to an optimal position allowing maximum usable torque without stalling the engine. In a sense, the engine/pump combination thinks and reacts to its environment without the need for operator input.

## Mechanical Levers

New Holland LS180 hydrostatic pumps are separated, resulting in more leak points. They are also modulated by servo controls which use mechanical “row boat” linkages to control a valve that directs hydraulic oil to a cylinder, that in turn moves the swash plate. The farther the operator pushes the levers forward or backward results in more flow going to the drive motors, therefore the machine will move faster. When a load is being applied to the machine, the operator must manually modulate hydraulic flow through the directional levers to keep the engine from stalling. **When using servo controls there is no direct mechanical link to the pumps, making it difficult to sense or “a feeling for” loads being put on the machine, hence the operator’s ability to modulate the flow is limited. The New Holland LS180 system requires more thought and operator experience in order to be as productive as the Caterpillar 252.**

## Pumps

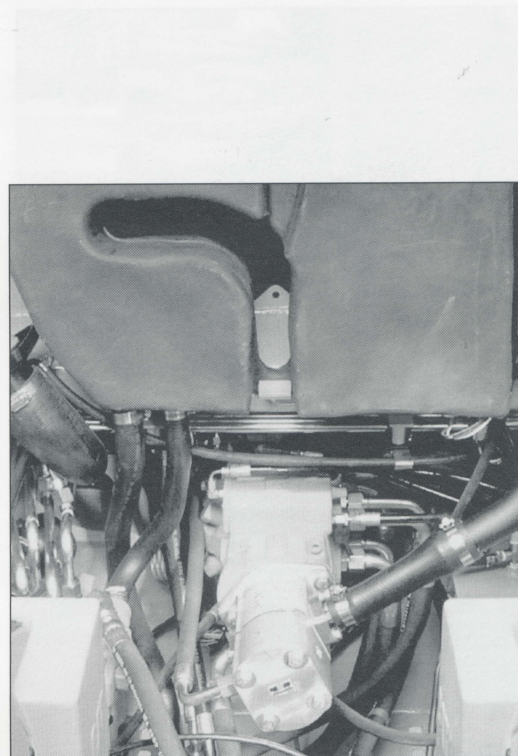

252 single-housing pumps

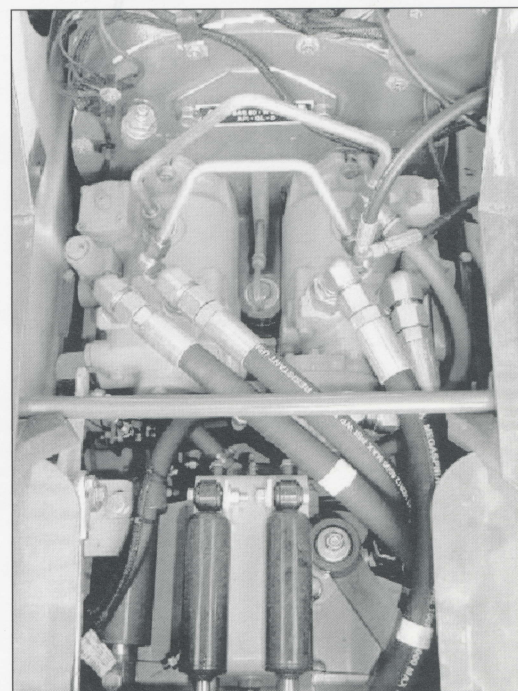

LS180 separate hystat pumps

# Drive System

## Axle/Wheel Mounting

- Caterpillar permanently sealed and lubricated for life axles with a labyrinth outer lip seal offers maximum protection, increased reliability and no maintenance
- New Holland axles require greasing every 500 hours leading to higher operating costs and more serviceable items
- New Holland's wide frame prevents a narrow width configuration, limiting versatility of the machine

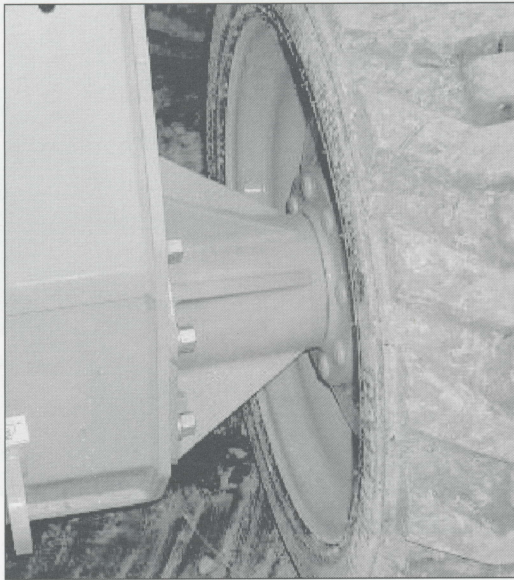

252 axle

### Axles

The Caterpillar 252 axle assembly is permanently sealed and lubricated, no greasing is required. The assembly features an outer seal with a labyrinth design for maximum bearing protection and an inner seal that keeps the chain case oil and its contaminants away from the permanently sealed and lubricated bearings. Since there is a chain case located on each side of the frame and the axle housings are bolted to the mainframe, the hub, axle housing and axle can easily be removed for quick service of seals and bearings if necessary. Having a separate chain case for each side also allows the use of a shorter axle. The 252 also features a flanged axle hub design that protects seals from damage.

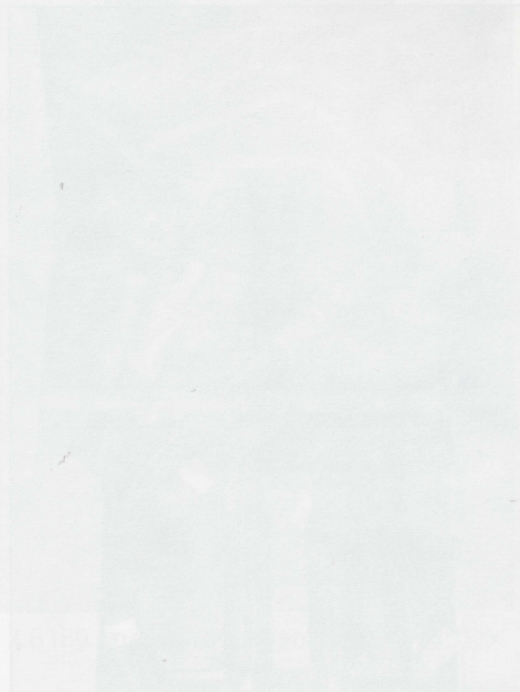

## Axle Grease Zerks (Grease Points)

New Holland LS180 axles are not permanently sealed and lubricated, requiring the operator to perform regular grease intervals every 500 hours. **The zerks (grease points) are positioned on the axles so that the rim and tires must be removed for greasing.** Furthermore, anytime an avenue for grease to enter is available, the chance of unwanted material contamination is increased.

### Wide Frame Arrangement

The wide frame of the LS180 prevents New Holland from having a 1676.4 mm (66 in) tire arrangement. The Cat 252 can be configured to a 1676.4 or 1828.8 mm (66 or 72 in) tire arrangement using standard size 304.8 x 419.1 (12 x 16.5) tires. Not being able to configure to 1676.4 mm (66 in) wide with standard tires restricts the LS180's ability to operate in tight places due to width restrictions, less traction and flotation. The wide frame of the New Holland also results in having to use wheel spacers or turn the wheels around in order to use steel tracks on the machine. If the tires are turned around, the width of the machine becomes 1981.2 mm (78 in) rather than 1828.8 mm (72 in) and the valve stem will be located on the inside of the rim rather than the outside — making the tire difficult to service. When wheel spacers are used, the parts have to be bought and installed which costs money and time and increases the overall width of the machine. The Caterpillar 252 can receive tracks at 1828 mm (72 in) wide with no wheel spacers.

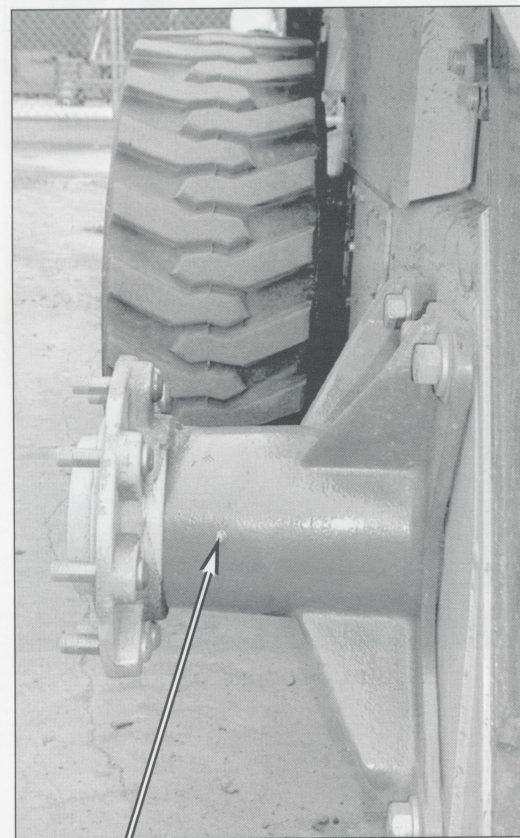

LS180 axle

Grease zerk



LS180 spacing



252 spacing

- Caterpillar offers superior cooling and serviceability with side-by-side coolers and hydraulically driven fan
- Caterpillar hydraulic tank increases pump life by purging air from the oil
- New Holland inefficient cooling system offers stacked coolers with a belt powered fan
- Caterpillar blowing system gets hot air away from operator and anyone nearby

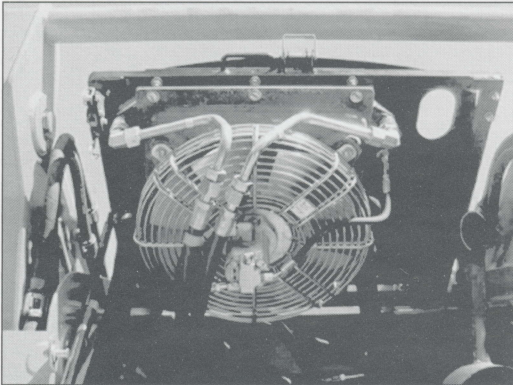

252 tilt-up cooling package

## Cooling Package

The Caterpillar 252 state-of-the-art cooling system is not only ideal for serviceability but it also has high ambient temperature capability. The cooling system (which consists of a hydraulically driven fan, steel fan guard, shroud, radiator/hydraulic oil cooler and grill) can be tilted 45 degrees from the closed position with the use of a pneumatically assisted strut (no tools are necessary). The side-by-side, single-core, aluminum V-wave design is more efficient and easier to clean than the traditional stacked design where preheated air flows from one cooler to the next. The 252's cooling system is paired up with a technologically advanced hydraulic tank, which is 53.3 percent larger than the LS180's tank, and features a baffle that forces hydraulic oil to stay in the tank longer. The 252's increased tank volume and baffle slows the oil's velocity and purges the air from the oil, as well as allowing other contaminants to settle out. This system prevents cavitation of the pumps which causes increased noise and reduced pump life.

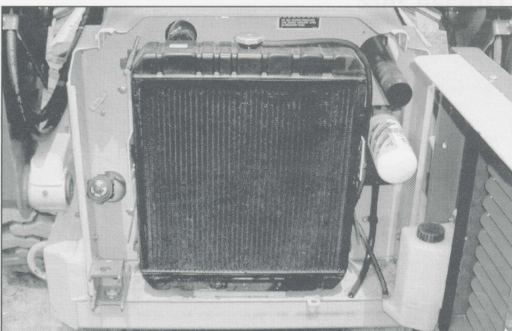

LS180 stacked coolers

The New Holland LS180 has a hydraulic oil cooler, engine oil cooler and grill stacked at the rear of the machine, making it difficult to service, clean and inefficient for cooling. Plus, the cooling system is more susceptible to damage stationed at the rear of the machine. When the fan pulls air through the grill, it first goes through the oil cooler then to the radiator stacked behind the oil cooler. With stacked coolers, the air gets heated from the first before entering the second, thereby decreasing the effectiveness of the second cooler.

### Accessibility

New Holland LS180 offers limited accessibility to both coolers. When debris gets in between the coolers, the operator will have a hard time cleaning it out. Furthermore, any type of maintenance needing to be done on the cooling system will be very difficult due to the limited space. With the Caterpillar 252, the operator has plenty of room to access the coolers via the tilt-up cooling package and side-by-side coolers, thus improving serviceability and accessibility.

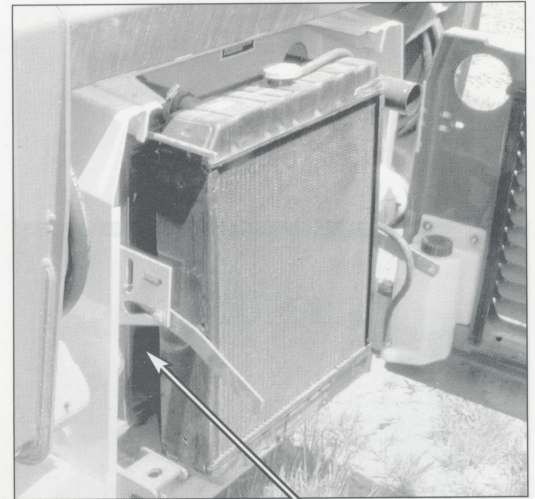

LS180 limited access

## Coupler/Work Tool Mounting

- **Universal coupler with tapered wedge pins ensures solid work tool mounting**
- **Caterpillar dual tilt cylinders are protected by the lift arms and increase visibility**

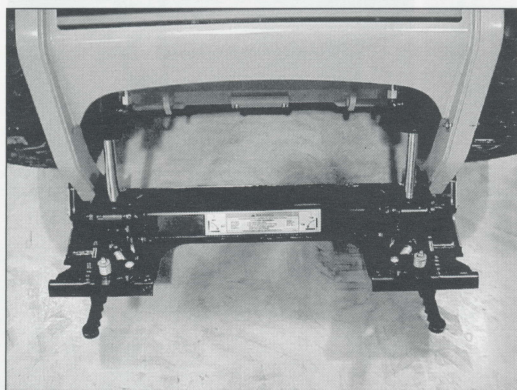

252 coupler

### Coupler

The Caterpillar 252 features a spring-loaded universal quick coupler with tapered wedge pins that compensate for wear and ensures solid work tool mounting. The wedges are also easily greased for increased service life. The dual tilt cylinder design allows for a spreading out of stresses, ensuring longer component life. The tilt cylinders are placed under the lift arms to protect the cylinders and rods and increase visibility.

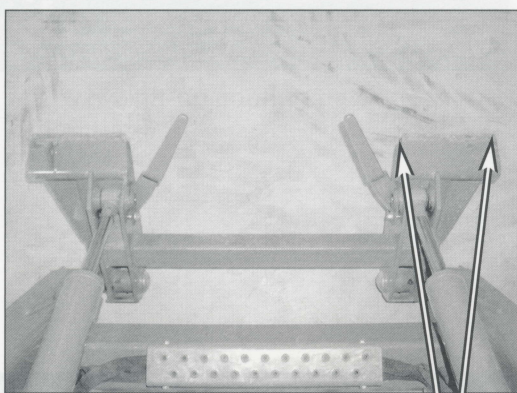

LS180 coupler

Weak  
point

The New Holland LS180 uses the same vertical wedge pin design as the Caterpillar 252. The coupler is attached to the lift arms with two tapered pivot pins. These pins are extremely difficult to service, requiring excessive pounding to remove them from their mating bores. Additionally, both tilt cylinders are exposed, decreasing visibility and increasing wear and damage to the cylinders and rods.

New Holland's coupler has two weak points located at the top of the coupler plate. When worn, the plates provide a loose connection to the work tool so the lower pins do not engage far enough through the tabs. This could pose a real safety concern if a work tool was to fall off during operation.

**Both couplers are universal and will thus allow for the interchangeability of work tools; however, as with all machines, secure work tool engagement does not necessarily guarantee that the machine/work tool will connect hydraulically, function properly or perform optimally.** The size of the couplers, pressure ranges of the tool and flow requirements of the tool must all be considered when determining work tool interchangeability.

- Caterpillar instrument panels are placed in the cab to maximize operator visibility and functionality
- New Holland instrument panels are located directly in front of the operator, limiting operator visibility

## Instrument Panels

The Caterpillar 252 features warning lights and an audible alarm for engine coolant temperature, engine oil pressure and hydraulic oil temperature. There are additional indicators for air filter restriction, alternator output, hydraulic filter restriction, hydraulic override, seat belt and parking brake. Depending on the machine configuration, the left side panel of the machine may also include rocker switches for continuous flow hydraulics, interlock override, work tool self-leveling and continuous electric current. The standard 252 comes complete with rocker switches for the parking brake and glow plug actuation. Additional instrumentation features on the 252 include an easy to read fuel gauge and a digital hour meter that can be read without having to enter the cab.

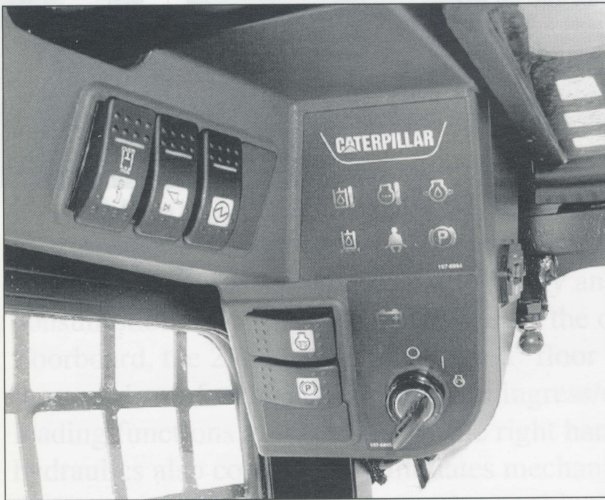

252 instrument panels

The New Holland LS180's instrument panel is located directly in front of the operator, limiting visibility — especially when the loader arms are raised. New Holland uses a wide range of indicators to comprise their “advanced warning system.” This system monitors engine functions and operator controls while, at the same time, controlling safety interlocks to the boom and bucket. The electronic instrument cluster (EIC) contains all the function lights along with the audible alarm. The operator has the ability to scroll through some of the functions which provide feedback on the condition of the machine. The ignition and working lights switch is located next to the EIC. No self-leveling option is available for the LS180.

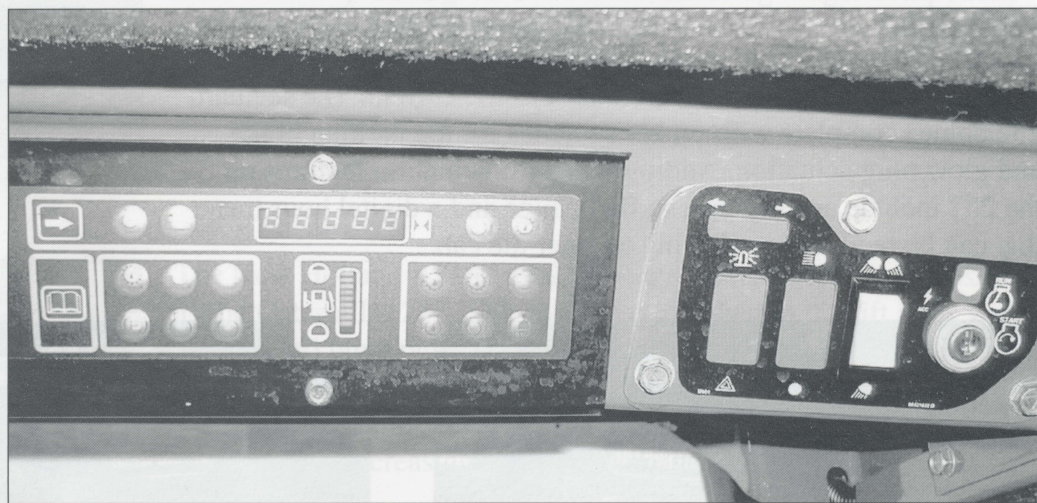

LS180 instrument panel

- Caterpillar low effort ISO style pilot hydraulic controls make the machine easier to operate and allow for one hand travel
- Caterpillar standard hand and foot throttle enables the operator to set the engine at a constant speed or use the foot throttle, improving fuel economy, allowing smoother operation and decreasing noise
- New Holland foot pedals require a great deal of effort, dexterity and coordination
- Caterpillar spring applied, hydraulically released brakes provide superior function and safety

### Pilot Controls

The low-effort, ISO style pilot hydraulic controls are one of the best selling features for the Caterpillar 252. They have revolutionized the industry by allowing for one-hand travel, eliminating arm movement, providing a quicker response, improving serviceability, increasing machine life/reliability and greatly increasing operator comfort. The pilot controls allow the operator to actually use the armrest and operate all of the skid steer loader functions without moving his/her arms.

### Hand and Foot Throttle

All of the drive functions are controlled with the left hand; making it possible to adjust the hand throttle during travel. The standard foot throttle is located on the floorboard and gives the operator the ability to use it for increased controllability and improved fuel consumption. With the foot throttle being the only thing on the floorboard, the 252 has an "uncluttered" floor plate, providing increased comfort and easier operator ingress/egress. All of the loading functions are operated by the right hand. The pilot hydraulics also completely eliminates mechanical linkages which decrease machine life and clutter the machine's serviceability.

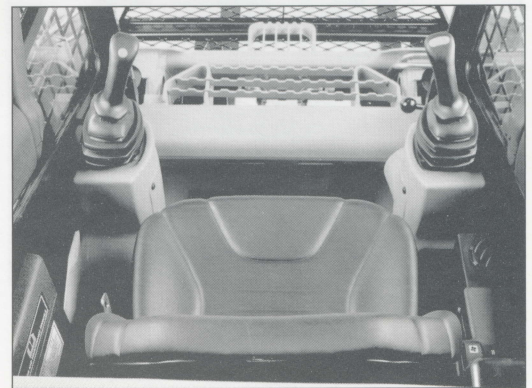

252 controls

# Loader Controls/Parking Brake



LS180 controls

## Foot Pedal Operation

The New Holland LS180 comes standard with foot pedals for all loader functions. Foot pedals require a great deal of effort, dexterity and coordination. They are also extremely hard to modulate, susceptible to filling with debris, “clutter” the floor plate and hard on operators.

## “Row Boat” Levers

All of the drive functions are controlled with the use of two long-stroke, “row boat” levers. The combination of foot pedals and levers greatly compromises productivity, responsiveness and operator comfort. The LS180 also has multiple mechanical levers, which clutter the machine’s mainframe, decreasing serviceability and increasing the number of movable parts on the machine.

## Parking Brake

The Caterpillar 252 uses spring applied, hydraulically released, multiple wet disc brakes. The flip of a rocker switch on the left side instrument panel releases hydraulic oil that pushes against springs to release the wet disc brakes. The New Holland LS180 uses a mechanical linked double disc brake system. Both discs are attached to each of the hydrostatic motor shafts located inside the gearboxes. Both left and right parking brakes are engaged by a single control lever that requires extra operator effort to apply and release. Because of the mechanical linkage, New Holland introduces more wearable parts, increasing operation costs while, at the same time, requiring constant adjustment. Additionally, the 252’s parking brake is automatically engaged when the arm bar is raised, doubling as a built in safety feature. The LS180 does not come standard with an arm bar and the parking brake must be manually applied. The operator can exit the cab without the parking brake being applied which is a safety concern. The seat belt on the LS180 must be engaged before the boom and bucket are operational. This proclaimed safety feature can be easily bypassed by simply engaging the seat belt behind the operator which results in no operator protection.

# Serviceability Access to Rear Compartment

- **Caterpillar in-line mounted engine and tilt up cooling package provides unparalleled access to all components**
- **New Holland offers limited access to engine and surrounding components when lift arms are down**

## Access

The Caterpillar 252 features an in-line mounted engine that allows for easy access to all engine components, creates extra room for battery removal, removes the need for gear driven pumps and reduces engine vibration. The Cat 3034 was made with serviceability in mind featuring grouped vertically mounted spin-on filters which reduce fluid spills, a bayonet mounted fuel water separator, an engine oil sampling port for preventive maintenance and a convenient oil drain hose which can be easily drained without turning a wrench.

The radiator, hydraulic oil cooler and grill all tilt-up and out of the way for wide-open access to all sides of the engine. The 252 proves the advantages of a hydraulically driven fan — with a hydraulically driven fan, there is no need for wear items like belts and bevel gears.

## ET Port

All Caterpillar machines come standard with an Electronic Technician (ET) diagnostic port which allows the service technician to plug in a laptop computer and receive fault codes to quickly diagnose problems concerning the auxiliary hydraulics. This greatly improves machine serviceability by allowing the technician to quickly identify the problem, thereby reducing downtime and minimizing the cost of labor to the customer. New Holland machines do not offer this diagnostic port which forces the technicians to perform time consuming tests to determine all sources of machine problems.

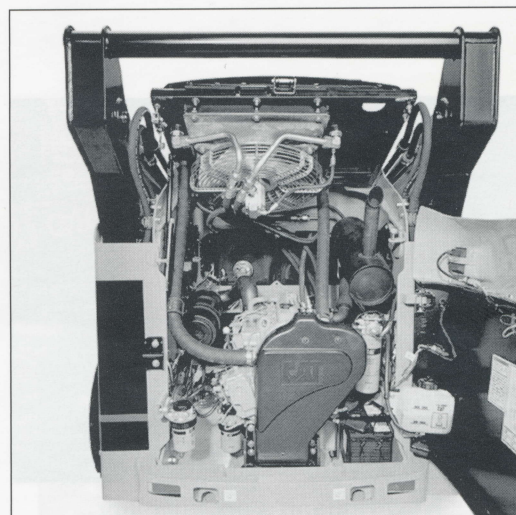

LS180 cluttered main frame

## Serviceability Access to Rear Compartment

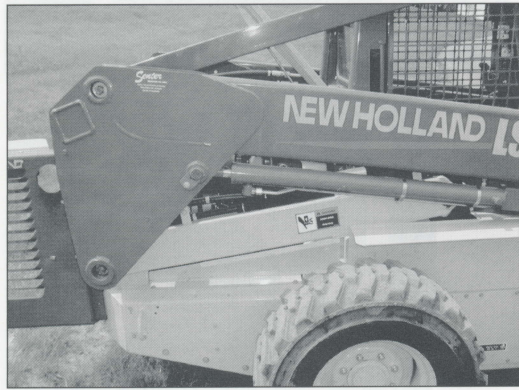

New Holland's accessibility

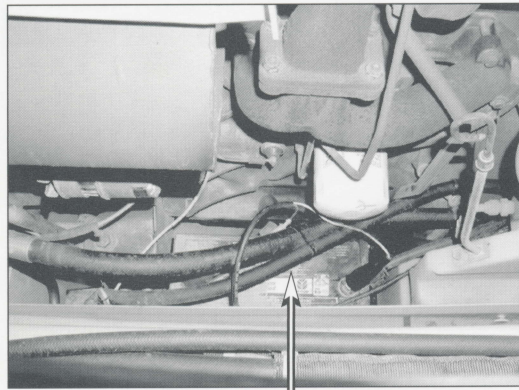

New Holland's battery access

### Serviceability

Other rear compartment serviceability features include a maintenance-free battery; hydraulic oil sampling port; hydraulic/engine oil pressure test ports; convenient air restriction indicator; easy to service dual element, radial seal air cleaner; color-coded and numbered wiring with Deutsch connectors; electronic control module; and carefully routed wiring harnesses and hydraulic lines.

The New Holland LS180 has an in-line mounted engine with removable side panels, but accessing the engine components is very difficult due to loader arm obstruction. To access components surrounding the engine such as the battery and fuse box, the loader arms must be put into the raised position. The radiator and oil cooler are stacked towards the rear of the machine where they are more prone to damage while, at the same time, offering limited serviceability. The hydraulic tank on the LS180 sits very close to the engine and has been known to melt, distorting the shape of the tank and causing inaccurate oil readings. Furthermore, the LS180 has no oil sampling ports, no hydraulic test ports, uses side-mounted filters, a dipstick instead of a sight gauge for hydraulic oil, as well as a drain hose for hydraulic fluid that requires two wrenches to drain the oil.

- Caterpillar tilt up cab provides unparalleled access to all hydraulic components
- Uncluttered lower frame due to 252 direct coupling to the engine, dual chain cases and no mechanical linkages provide superior service and access
- New Holland's additional gearboxes along with mechanical levers clutter the frame, decreasing serviceability and accessibility

## Access

The Caterpillar 252 features a tilt-up cab that provides unparalleled access to all hydraulic and hydrostatic components. With the use of pilot controls, there are absolutely no mechanical linkages to clutter service space. Pumps are directly coupled to an in-line mounted engine allowing for convenient in-line placement of the pumps. The 252 also features wide-open access to the hydrostatic radial piston motors, valve block and hydraulic tank (see photo).

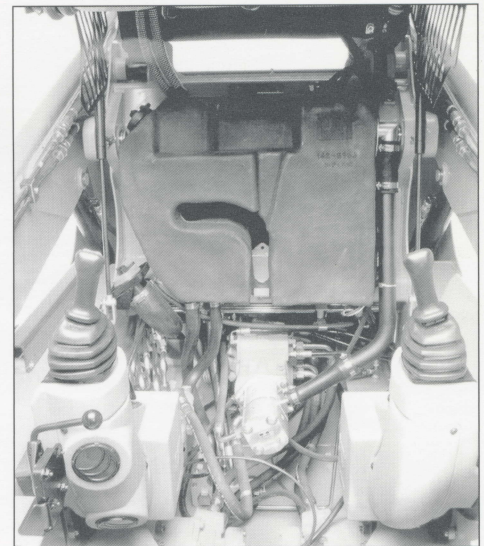

252 wide-open accessibility

## Main Frame

The New Holland LS180 has a cluttered main frame cavity. There are multiple mechanical steering levers linking the "row boat" controls to the hydrostatic pumps which must be removed to service the hydrostatic/hydraulic systems. Furthermore, an engine-to-transmission gearbox along with, final drive gearboxes further clutter up the main frame, decreasing serviceability and accessibility to lower frame components.

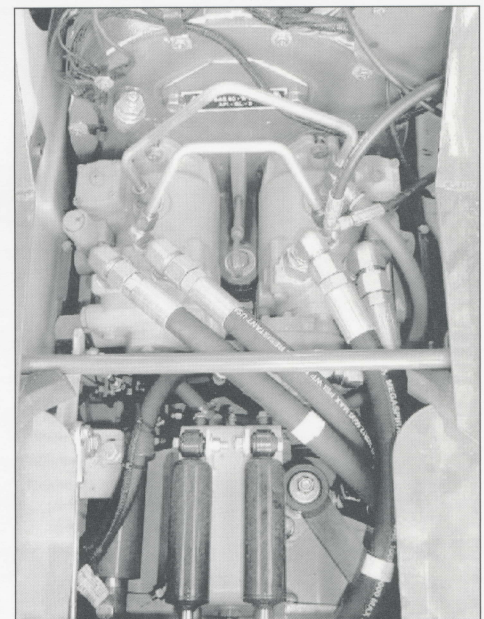

LS180 cluttered main frame

## Cab Tilting

Tilting the cab on the LS180 is quite a lengthy, 19 step process that takes approximately two hours and involves the use of special tooling to secure the frame upright. This process is crucial since access to mainframe components is very limited with the cab down. New Holland claims by simply lifting the seat and removing the floor plate that components such as final drive gearboxes are readily accessible. The LS180 picture (page 27) was taken with the seat up and floor plate removed. From an accessibility standpoint, that is as good as it gets with the New Holland LS180. Removing the floor plate still requires service to be done in tight quarters and removal of eight bolts. Additionally, an access panel and nut have to be removed to drain the hydraulic reservoir.

## Advantages

Other serviceability advantages with the Caterpillar 252 include: countersunk grease fittings; a convenient hydraulic site gauge; careful hose/harness routing; exclusive use of sealed pin connectors; a fuse box which is accessible from inside the cab; removable axle housings that allow for chain adjustment; removable belly pan for superior cleanout; and excellent access in the rear compartment.

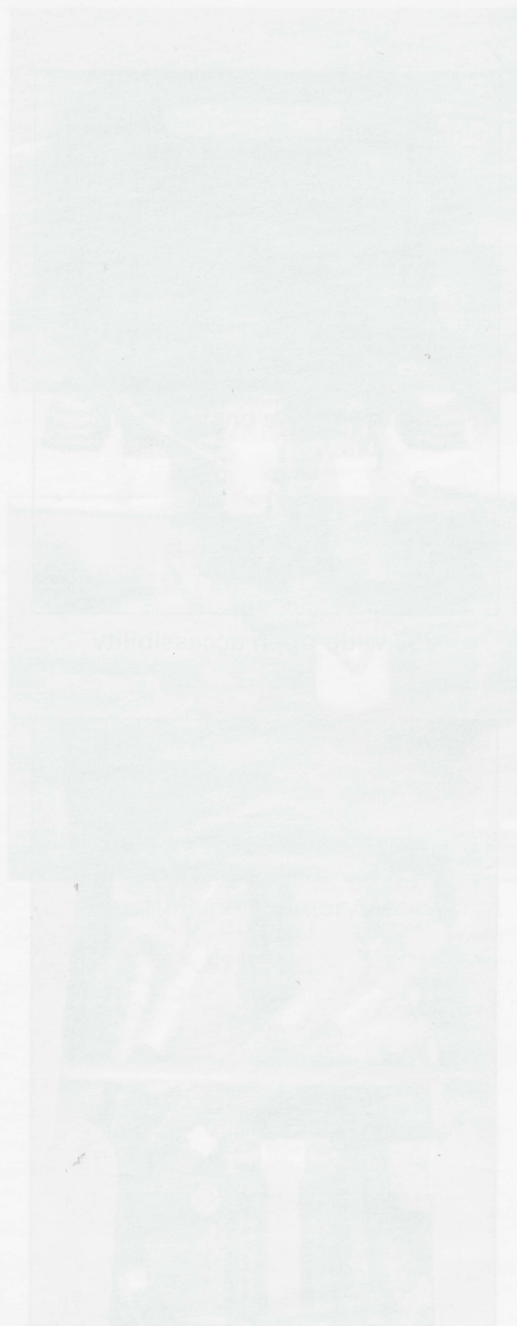

## Key Selling Points vs. New Holland LS180

---

1. The Caterpillar 252 provides 6 percent, 38 kN vs. 35.8 kN (8,550 lbf vs. 8,041 lbf) more available power at the wheels (rimpull) and 50 percent more hydraulic horsepower (31.6 kW vs. 21 kW [42.4 hp vs. 28.1 hp]) than the New Holland LS180. This additional power allows the 252 to push through larger piles and pull itself out of holes that the LS180 cannot, as well as have the extra hydro-mechanical torque needed to fight through the toughest jobs.
2. The Caterpillar 252 higher rated operating capacity of 23 kg (50 lb) (1020.6 kg vs. 997.9 kg [2,250 lb. vs. 2,200 lb]) compared to the New Holland LS180 makes the 252 a more versatile and productive machine by being able to lift and carry heavier loads on the jobsite.
3. The Caterpillar 252 higher hinge pin height of 78.7 mm (3.1 in) (3243.6 mm vs. 3164.8 mm [127.7 in vs. 124.6 in]) allows for higher placement of materials and more clearance over trucks resulting in increased productivity and less damage. When dumping material into a truck, the 252 has superior cleanout due to its 50 degree maximum dump angle compared to the 45 degrees that the New Holland LS180 attains. The additional dump angle allows the operator to dump materials quicker resulting in increased productivity.
4. The Caterpillar 252 uses non-tapered cantilevered pins (same diameter all the way through) coupled with a spherical bearing where it attaches to the frame to prevent point loading and premature pin wear. This spherical bearing allows the 252 linkage to flex and distribute the load from the lift arms into the frame, reducing the chance of fatigue cracks. The New Holland LS180 linkage does not flex using tapered cantilevered pins resulting in decreased serviceability and a shorter life.
5. Caterpillar offers a cross member that connects the loader arms, links and frame together via a control link which provides a stiff, stable structure and prevents torsional loading. New Holland lacks a cross member that connects the linkage as one. This allows the links to move independently causing the lift arms to get so loose that New Holland has put wear strips on the sides of the cab to protect the machine's frame from the lift arms.
6. The Caterpillar 252 has much more usable reach throughout its lift cycle compared to the New Holland LS180. The lift path of the LS180 limits the amount of reach, meaning maximum reach is towards the very top of their lift cycle. At a height of 1651 mm (65 in), the LS180 has a hinge pin reach of 317.5 mm (12.5 in) and the 252 has a reach of 408.9 mm (16.1 in).

## Key Selling Points vs. New Holland LS180

---

7. The Caterpillar 252 exclusive anti-stall feature delivers maximum usable torque at all times without stalling the engine, allowing operators to dig aggressively.
8. The Caterpillar 252 uses dual tilt cylinders protected by a torque tube that provides greater cylinder protection, easier machine ingress/egress, a superior viewing area to the cutting edge and faster hydraulic cycle times than the New Holland LS180. The 252 also has 19.6 percent more breakout force for the lift circuit (22.3 kN vs. 18.7 kN [5,020 lb. vs. 4,194 lb]).
9. The Caterpillar 252 axle assembly is permanently sealed/lubricated. The New Holland LS180 axle requires greasing every 500 hours which adds another serviceable item to the machine.
10. The Caterpillar 252 has a direct coupling between the hydrostatic/hydraulic pump line and the in-line mounted Cat 3034 engine. This design takes away the need for belt driven pumps and allows for wide-open serviceability to the hydrostatic and hydraulic pumps. The New Holland LS180 uses an engine-to-transmission gearbox to transfer power from the engine to the hydrostatic pumps through an internal gear set (spur gear set). This design introduces more wearable parts into the hydraulic system increasing operating costs, while at the same time, cluttering the main frame and limiting accessibility to other components. Additionally, a gearbox style system is not as efficient as a direct coupling system which leads to a loss of horsepower.
11. The Caterpillar 252 features an in-line mounted engine that allows for easy access to all engine components, creates extra room for battery removal, eliminates the need for a gear driven pump and reduces engine vibration. The New Holland LS180 has an in-line mounted engine but accessibility and serviceability with the loader arms down is extremely poor compared to the 252.
12. The Caterpillar 3034 engine is equipped with four cylinders, offering the operator smooth, quiet operation. The New Holland 332T/JF engine has three cylinders. This engine tends to vibrate because it is unbalanced. It is also very noisy and could pose a reliability problem due to excessive component vibration.
13. Both the Caterpillar 252 and New Holland LS180 have a bow tie configuration for the drive chains. Power flows directly from the drive motors to the drive sprocket on the 252. However, New Holland adds an extra gearbox to its drive system between the drive motors and drive sprockets which clutters up the main frame and limits accessibility as well as adding more wearable parts and another service item.

14. The Caterpillar 252 features unmatched serviceability with vertical spin-on filters, a bayonet mounted fuel water separator, engine/hydraulic oil sampling ports, engine/hydraulic oil test ports, a convenient oil drain hose, a maintenance free battery, an air restriction indicator, a dual element air cleaner, color-coded/numbered wiring harnesses with Deutsch connectors, two electronic control modules, recessed grease fittings, good hose/harness routing, a tilt-up cooling package, removable /adjustable axle housings, no mechanical linkages, hydraulic/coolant site gauges, XT hydraulic hose, o-ring face seals and a fuse box that is accessible from the cab.
15. The Caterpillar 252 offers a metal fuel tank that is embedded into the frame to provide extra strength. The New Holland LS180 uses a plastic fuel tank that runs along the left side of the machine, very close to engine, pump and lever components. Because of its location, the fuel tank is susceptible to heat, abrasion and puncture holes that could lead to leaks.
16. The Caterpillar 252 features a foot throttle which in conjunction with the anti-stall feature improves fuel economy, allows for smoother operation, decreases noise and lengthens machine component life. With the anti-stall device, operators can easily run at low throttle and use the foot throttle when extra speed is needed.
17. The Caterpillar 252 cooling system features a hydraulically driven fan and a single-core design, which raises 45 degrees for easy cleaning/service and a technologically advanced hydraulic tank with 53.3 percent more capacity than the New Holland LS180. The 252 also comes standard with extended life coolant that does not need to be changed for four years or 6,000 hours with yearly replenish. The LS180 has a hydraulic oil cooler and radiator that are vertically mounted in front of each other, making it inefficient for cooling and difficult to clean and service. The fan is mechanically run by a belt and pulleys.
18. The Caterpillar 252 features low effort, ISO style hydraulic pilot controls which allow for one-hand travel, eliminate arm movement, provide a quicker response, improve serviceability, increase machine life/reliability and greatly increases operator comfort. The New Holland LS180 comes standard with foot pedals for all loader functions and "row boat" levers that require a great deal of effort, dexterity and coordination for all drive functions. Additionally, the LS180 lever system requires constant adjustment.

19. The Caterpillar 252 uses spring applied hydraulically released multiple wet disc brakes while the New Holland LS180 uses a mechanical linked double disk brake system, which requires adjustment, manual engagement, proposes safety issues and introduces more wearable parts.
20. By simply removing two cab bolts, the Caterpillar 252 offers a tilt-up cab that provides unparalleled access to all hydraulic and hydrostatic components. Tilting the cab on the New Holland LS180 requires the operator to perform a lengthy two hour, 19-step process which involves the use of special tooling.
21. The Caterpillar 252 can be configured to a 1676.4 mm or 1828.8 mm (66 or 72 in) tire arrangement using standard size 304.8 x 419.1 mm (12 x 16.5 in) tires. Because of the wide frame on the New Holland LS180, a 1676.4 mm (66 in) tire configuration cannot be attained using a standard width tire. Not being able to configure to 1676.4 mm (66 in) wide with standard tires restricts the LS180's ability to operate in tight places due to width restrictions, less traction and flotation.
22. The wide frame of the New Holland LS180 also results in having to use wheel spacers or turn the wheels around in order to use steel tracks on the machine. If the tires are turned around, the width of the machine becomes 1981.2 mm (78 in) rather than 1828.8 mm (72 in) and the valve stem will be located on the inside of the rim rather than on the outside which makes the tire difficult to service. When the wheel spacers are used, the parts have to be purchased and installed — costing money and time and the overall width of the machine increases. The Caterpillar 252 can receive tracks at 1828.8 mm (72 in) wide with **no wheel spacers**.
23. The Caterpillar 252 offers more ground clearance (228.6 mm vs. 203.2 mm [9 in vs. 8 in]) than the New Holland LS180, allowing the 252 to pass over obstructions and minimize the chance of getting hung up.

This material compares the features and specifications of competitive machines. The information contained herein is intended for circulation only to Caterpillar dealer employees whose duties require such reports, and is intended exclusively for information and training. It may contain unverified analysis and facts observed by various Caterpillar or dealer employees; however, effort has been made to provide reliable information comparing Caterpillar-built and competitive machines. Effort has been made to use the latest available specifications and other materials in the full understanding that these are subject to change without notice. Any complete or partial reproduction of this release without the foregoing explanation is prohibited.