

ENGINE

Power output (Acc. to ISO 1585).....	75 kW (102 HP)
Net brake power	67 kW (91 HP)
Manufacturer	Deutz
Model.....	BF4M 2012
Piston displacement.....	4000 cm ³
Max. RPM	2000 min ⁻¹
Charging	Turbocharged

HYDRAULIC SYSTEM

Computer controlled AWE5 system with one load limit controlled high performance piston pump and fuel saving oil supply on demand in order to ensure sensitive, proportional and load independent control of all movements. • primary and secondary safeguarding of the hydraulic system against overload • anti cavitation valves for all working functions, throttle control in the lifting and folding circuit • Load – holding valves and subtile acting lowering valves in the lifting circuit

Hydraulic system	1x axial piston pump
Main pump	A11VO95
Max. gear pump output.....	188 l/min
Max. operating pressur	360 bar

NOISE LEVEL

Noise level* well below EU limits

Outside cab (LwA).....	100 dB (A)
Inside cab (LpA)	75 dB (A)

*dynamic noise measurements acc. 2000 / 14 EU regulations

ELECTRICAL SYSTEM

Operating voltage	24 Volt
Cold-start high performance batteries	2 x 100 Ah
Complete electrical system acc. SiVZO	

BRAKE

Twin-circuit system.....	Multi-disc brakes
Parking brakes	Multi-disc brakes

TANK VOLUMES

Fuel tank.....	194 l
Hydraulic tank	150 l
Engine oil tank.....	10 l

CABIN

Shock absorbing resilient mountings • heat insulated panoramic windows for best all around visibility • no glare interior • skylight with window • ergonomic control levers • adjustable steering column • forward and reverse seat adjustment, independent of the control panel • Up and over windscreen lockable under roof panel • air condition

Model.....	ATLAS comfort cab model 935-5
Total length.....	1770 mm
Width	935 mm



SLEWING MECHANISM

Slew motor.....	Axial piston with priority valve
Slew gear box	planetary gearing
Slew brake.....	lockable multi disc
Drive internally toothed	
Slewing speed	9 min ⁻¹
Slewing torque.....	34.7 kNm

DRIVE

40 to special excavator axles with planetary gears in all four wheel hubs • all wheel drive • variable speed motor • powershift transmission • double acting travel brake valve • direction control lever (for./rev.) on steering column • steering axle with automatic blocking of the pendulum axle • accelerator pedal control

TRAVELLING SPEED

Inching	max. 1.0 km/h
Off road (infinitely)	max. 5.0 km/h
On road (infinitely)	max. 20 km/h
High-speed (optional)	max. 30 km/h

TYRES

8-fold	10.00 - 20
4-fold (optionally)	600/40 - 22,5
Turning radius	7.5 m

OPERATION WEIGHT

Operation weight	13.9 - 14.3 to
------------------------	----------------

PRINCIPAL DIMENSIONS

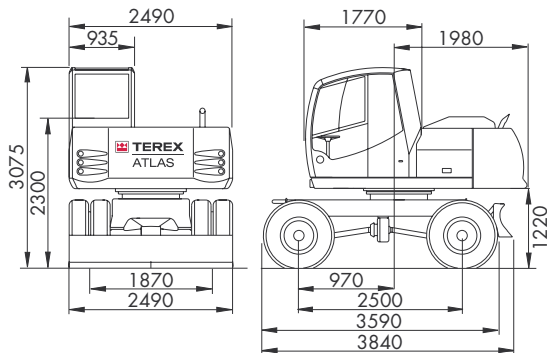

TRAVELLING POSITION WITH BUCKET

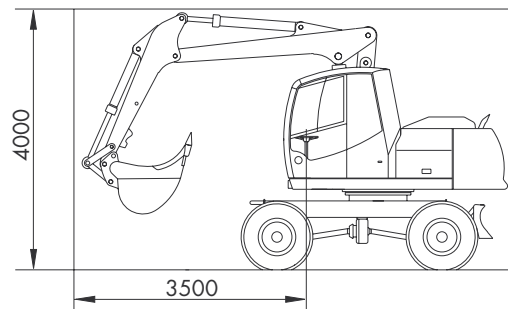

BOOM SYSTEMS

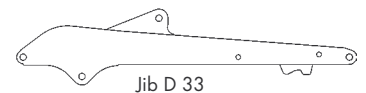
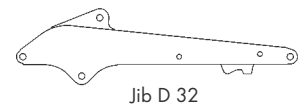
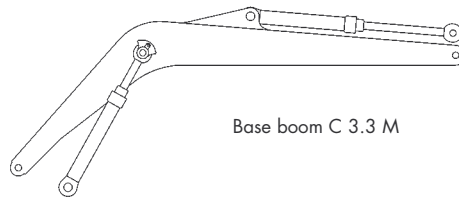
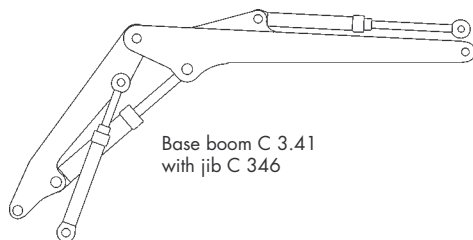

EQUIPMENT

Basic unit

		Weight/kg
A 3.2	ATLAS fully hydraulic mobile excavator 1305 M with dozer blade and two lift rams	10750
A 3.32	The 1305 M ATLAS hydraulic mobile excavator as the A 3.2, but with a four-fold stabilizers with cylinder protection and movable outriggers by means of 4 individual cylinders (B 3.9 or 3.9 b recommended) and two lift rams	
A 3.33	The 1305 M ATLAS hydraulic mobile excavator as the A 3.2, but with a fully-installed dozer blade behind the rigid axle and 2-fold stabilizers with cylinder protection and movable outriggers in front of the steering-type axle (B 3.9 absolutely essential) and two lift rams	
A 3.35	The 1305 M ATLAS hydraulic mobile excavator as the A 3.2, but with a fully-installed dozer blade in front of the steering-type axle and 2-fold stabilizers with cylinder protection and movable outriggers behind the rigid axle, without grab storage place on the carrier, (B 3.9 absolutely essential) and two lift rams	

Additional equipment

B 3.9	Hydraulic installation for mobile excavators in order to be able to switch the front and rear stabilizers individually	30
B 3.9b	Hydraulic installation for mobile excavators in order to be able to switch four stabilizers individual	40
B 3.9c	Hydraulic installation for mobile excavators in order to be able to switch two claws individual	30
B 6.55	Wider axles, total width 2750 mm	230
B 6.56	Wider dozer blade, total width 2750m mm	30

Base and secondary booms

		Weight/kg
C 3.3 M	Standard- monobloc with jib ram, effective length 4220 mm	880
C 3.41	Base boom with single ram, including hydraulic installation set	870
C 346	Secondary boom with one jib ram, only for base boom C3.41, effective length 2940 mm	720

Jibs

D 32	Standard jib, effective length 1960 mm	380
D 33	Special jib, effective length 2500 mm	420

Bucket ram

F 31	Bucket ram with linkage	165
-------------	-------------------------	-----

Standard equipment:

- AEM ATLAS EXCAVATOR MANAGEMENT
- Excavator electronics
- LCD showing operating data
- climatronic
- travelling with foot pedals
- automotive movement
- pre-selected direction on the pilot control lever
- Automatic idle running (diesel engine)
- pressure switch-on
- Sliding window in the cab door
- heat-resistant
- shade-lite glass panes
- windscreen can be pushed under the cab roof
- steering column, tilting and height continuously-adjustable
- arm bracket can be lifted and lowered
- comfort seat with arm rests and lumbar support
- forward and reverse seat adjustment independent of the control panel
- cab prepared for radio installation
- battery main switch in the negative wire
- pressure reservoir for emergency lowering of the arm system
- Combined lubrication points
- sealed pivot points in the base arm
- grab handle to suspend the grab while driving on the road
- intermediate rings between the tyre pairs
- toolbox in the superstructure
- windscreen washer
- Hydraulic installation set for grab operation and for grab slewing operation (grab rotation NW 16)
- valve assembly on the boom mounted for the attachment of additional valves
- pipe-break safety device for the lifting cylinders with an overload warning device
- automatic slewing gear brake

ATLAS 1305 M hydraulically adjustable booms

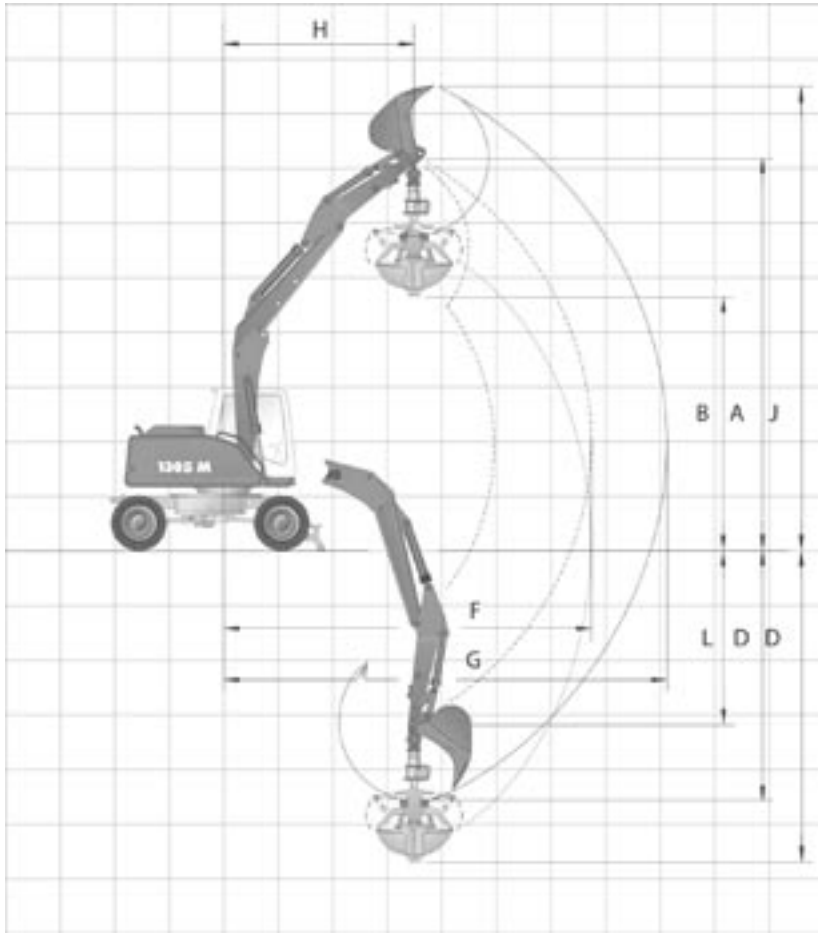

Equipment: A 3.2, C 3.41, C 346, F 415 oder E 38

Jib D 32 - Effective length 1960 mm

		Bucket	Grab
A	Jib height	mm	7700
B	Dumping height	mm	5250
D	Max. digging depth	mm	4900
F	Max. length of depth	mm	6950
G	Max. outreach	mm	8350
H	Max. outreach length	mm	2750
J	Max. outreach heigh	mm	9100
L	Bucket pivot	mm	3500
	Bucket/grab	l	670
	Tear out force	kN	64
	Brake out force	kN	106
	Grab closing force	kN	73
	Operation weight	t	13.4

Equipment: A 3.2, C 3.41, C 346, Ausrüstung:F 415 oder E 37

Jib D 33 - Effective length 2500 mm

		Bucket	Grab
A	Jib height	mm	8100
B	Dumping height	mm	5650
D	Max. digging depth	mm	5400
F	Max. length of depth	mm	7450
G	Max. outreach	mm	8850
H	Max. outreach length	mm	3150
J	Max. outreach heigh	mm	9500
L	Bucket pivot	mm	4000
	Bucket/grab	l	670
	Tear out force	kN	55
	Brake out force	kN	106
	Grab closing force	kN	73
	Operation weight	t	13.5

ATLAS 1305 M Monobloc

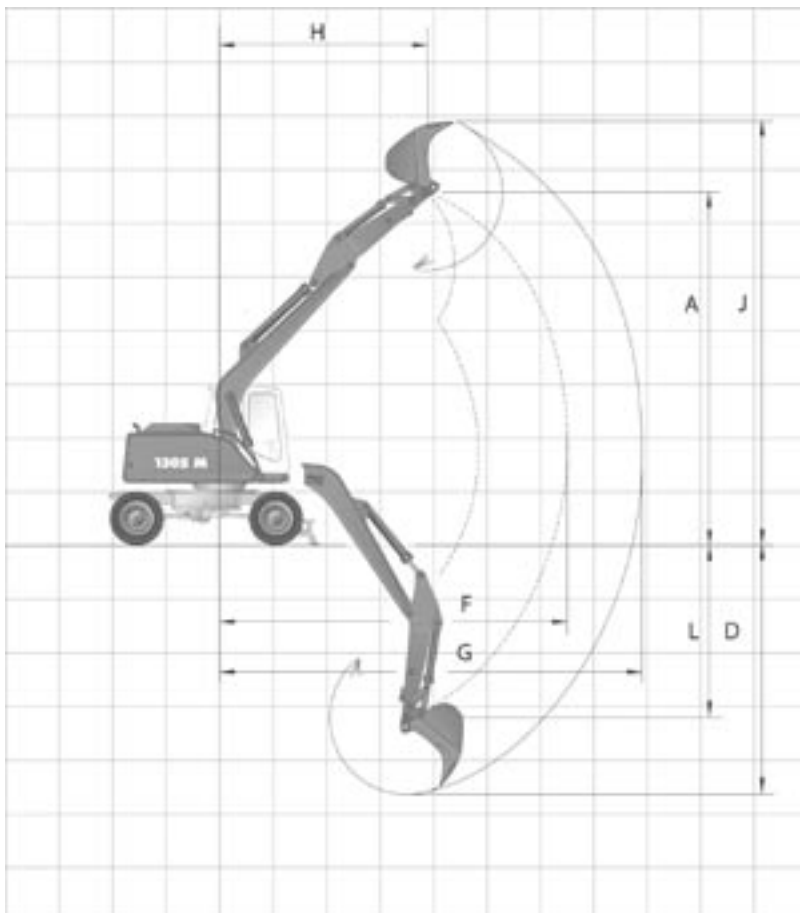

Equipment: A 3.2, C 3.3 M, F 415

Jib D 33 - Effective length 2500 mm

		Bucket
A	Jib height	mm
B	Dumping height	mm
D	Max. digging depth	mm
F	Max. length of depth	mm
G	Max. outreach	mm
H	Max. outreach length	mm
J	Max. outreach heigh	mm
L	Bucket pivot	mm
	Bucket/grab	l
	Tear out force	kN
	Brake out force	kN
	Grab closing force	kN
	Operation weight	t

Equipment: A 3.2, C 3.3 M, F 415

Jib D 33 - Effective length 2500 mm

		Bucket
A	Jib height	mm
B	Dumping height	mm
D	Max. digging depth	mm
F	Max. length of depth	mm
G	Max. outreach	mm
H	Max. outreach length	mm
J	Max. outreach heigh	mm
L	Bucket pivot	mm
	Bucket/grab	l
	Tear out force	kN
	Brake out force	kN
	Grab closing force	kN
	Operation weight	t

Equipment A 3.2, C 3.41, C 346

Jib D 32 - Effective length 1960 mm

Hook height m	3.0 m		4.0 m		4.5		5.0 m		5.5 m		6.0 m		6.5 m		
	long.	lat.	long.	lat.	long.	lat.	long.	lat.	long.	lat.	long.	lat.	long.	lat.	
5	a	-	-	3.7	3.7	3.5	3.5	3.3	3.1	3.1	2.7	-	-	-	-
	b	-	-	3.7	3.7	3.5	3.2	3.3	2.8	3.1	2.4	-	-	-	-
4.5	a	4.8	4.8	3.8	3.8	3.5	3.5	3.3	3.1	3.1	2.7	3.0	2.3	-	-
	b	4.8	4.8	3.8	3.8	3.5	3.2	3.3	2.8	3.1	2.4	3.0	2.0	-	-
3	a	5.4	5.4	4.5	4.1	4.0	3.5	3.6	3.0	3.3	2.7	3.1	2.3	2.9	2.0
	b	5.4	5.4	4.5	3.7	4.0	3.1	3.6	2.7	3.3	2.4	3.1	2.0	2.9	1.8
1	a	6.8	6.1	5.0	4.0	4.3	3.5	3.9	3.0	3.5	2.6	3.2	2.2	2.9	2.0
	b	6.8	5.3	5.0	3.6	4.3	3.1	3.9	2.7	3.5	2.3	3.2	2.0	2.9	1.7
0	a	7.0	6.1	5.0	4.0	4.4	3.4	3.9	2.9	3.5	2.5	3.2	2.2	2.8	1.9
	b	7.0	5.2	5.0	3.5	4.4	3.0	3.9	2.6	3.5	2.2	3.2	1.9	2.8	1.7
-1	a	7.2	6.0	5.1	3.9	4.5	3.3	4.0	2.8	3.5	2.4	2.9	2.1	-	-
	b	7.2	5.1	5.1	3.4	4.5	2.9	4.0	2.5	3.5	2.1	2.9	1.9	-	-
-3	a	6.1	6.0	3.7	3.7	-	-	-	-	-	-	-	-	-	-
	b	6.1	5.1	3.7	3.3	-	-	-	-	-	-	-	-	-	-

Jib D 33 - Effective length 2500 mm

Hook height m	3.0 m		4.5 m		5.0 m		5.5 m		6.0 m		6.5 m		7.0 m		
	long.	lat.	long.	lat.	long.	lat.	long.	lat.	long.	lat.	long.	lat.	long.	lat.	
5	a	-	-	3.1	3.1	3.0	3.0	2.9	2.7	2.8	2.4	2.3	2.0	-	-
	b	-	-	3.1	3.1	3.0	2.8	2.9	2.4	2.8	2.1	2.3	1.8	-	-
4.5	a	-	-	3.2	3.2	3.1	3.1	2.9	2.7	2.8	2.4	2.7	2.1	-	-
	b	-	-	3.2	3.2	3.1	2.8	2.9	2.4	2.8	2.1	2.7	1.8	-	-
3	a	5.2	5.2	3.7	3.5	3.4	3.0	3.1	2.7	2.9	2.4	2.7	2.1	2.6	1.8
	b	5.2	5.2	3.7	3.1	3.4	2.7	3.1	2.4	2.9	2.1	2.7	1.8	2.6	1.8
1	a	6.6	6.0	4.3	3.4	3.8	3.0	3.4	2.7	3.1	2.3	2.8	2.0	2.6	1.7
	b	6.6	5.3	4.3	3.1	3.8	2.7	3.4	2.3	3.1	2.0	2.8	1.7	2.6	1.5
0	a	6.9	6.0	4.3	3.4	3.8	3.0	3.4	2.6	3.1	2.2	2.9	1.9	2.5	1.7
	b	6.9	5.3	4.3	3.0	3.8	2.6	3.4	2.3	3.1	1.9	2.9	1.7	2.5	1.5
-1	a	7.0	6.0	4.3	3.3	3.9	2.9	3.5	2.5	3.2	2.1	2.7	1.9	-	-
	b	7.0	5.1	4.3	2.9	3.9	2.5	3.5	2.1	3.2	1.9	2.7	1.6	-	-
-3	a	7.1	6.0	3.8	3.2	3.0	2.7	2.1	2.1	-	-	-	-	-	-
	b	7.1	5.1	3.8	2.7	3.0	2.7	2.1	2.1	-	-	-	-	-	-

Equipment A 3.2, C 3.3M

Jib D 32 - Effective length 1960 mm

Hook height m	3.0 m		4.0 m		4.5 m		5.0 m		5.5 m		6.0 m		6.3 m		
	long.	lat.	long.	lat.	long.	lat.	long.	lat.	long.	lat.	long.	lat.	long.	lat.	
5	a	-	-	-	3.3	3.3	3.3	3.1	-	-	-	-	-	-	
	b	-	-	-	3.3	3.3	3.3	2.8	-	-	-	-	-	-	
4.5	a	-	-	-	3.4	3.4	3.3	3.1	3.2	2.7	-	-	-	-	
	b	-	-	-	3.4	3.2	3.3	2.8	3.2	2.4	-	-	-	-	
3	a	-	-	4.3	4.2	3.9	3.5	3.6	3.0	3.4	2.7	3.2	2.3	3.2	2.2
	b	-	-	4.3	3.7	3.9	3.1	3.6	2.7	3.4	2.3	3.2	2.1	3.2	1.9
1	a	-	-	5.2	3.9	4.6	3.3	4.1	2.9	3.7	2.5	3.4	2.3	3.2	2.1
	b	-	-	5.2	3.4	4.6	2.9	4.1	2.5	3.7	2.2	3.4	2.0	3.2	1.9
0	a	5.9	5.8	5.2	3.8	4.6	3.3	4.1	2.8	3.7	2.5	3.3	2.3	-	-
	b	5.9	5.0	5.2	3.3	4.6	2.8	4.1	2.5	3.7	2.2	3.3	2.0	-	-
-1	a	6.4	5.9	4.9	3.8	4.4	3.3	3.9	2.8	3.4	2.5	-	-	-	-
	b	6.4	5.0	4.9	3.3	4.4	2.8	3.9	2.5	3.4	2.2	-	-	-	-
-3	a	3.8	3.8	2.9	2.9	-	-	-	-	-	-	-	-	-	-
	b	3.8	3.8	2.9	2.9	-	-	-	-	-	-	-	-	-	-

Jib D 33 - Effective length 2500 mm

Hook height m	3.0 m		4.5 m		5.0		5.5 m		6.0 m		6.5 m		6.8 m		
	long.	lat.	long.	lat.	long.	lat.	long.	lat.	long.	lat.	long.	lat.	long.	lat.	
5	a	-	-	-	-	2.9	2.9	2.9	2.7	2.2	2.2	-	-	-	-
	b	-	-	-	-	2.9	2.8	2.9	2.4	2.2	2.1	-	-	-	-
4.5	a	-	-	-	-	2.9	2.9	2.9	2.7	2.8	2.4	-	-	-	-
	b	-	-	-	-	2.9	2.8	2.9	2.4	2.8	2.1	-	-	-	-
3	a	-	-	3.6	3.6	3.3	3.1	3.1	2.7	3.0	2.3	2.9	2.1	2.2	1.9
	b	-	-	3.6	3.1	3.3	2.7	3.1	2.4	3.0	2.1	2.9	1.8	2.2	1.7
1	a	-	-	4.4	3.3	3.9	2.9	3.6	2.5	3.3	2.3	3.0	2.0	2.9	1.9
	b	-	-	4.4	2.9	3.9	2.5	3.6	2.2	3.3	2.0	3.0	1.8	2.2	1.7
0	a	6.4	5.8	4.6	3.2	4.0	2.8	3.6	2.5	3.3	2.2	3.0	2.0	2.2	1.9
	b	6.4	4.9	4.6	2.8	4.0	2.5	3.6	2.2	3.3	1.9	3.0	1.8	2.2	1.7
-1	a	6.9	5.8	4.5	3.2	4.0	2.8	3.5	2.5	3.1	2.2	-	-	-	-
	b	6.9	4.9	4.5	2.8	4.0	2.4	3.5	2.2	3.1	1.9	-	-	-	-
-3	a	4.8	4.8	3.2	3.2	2.6	2.6	-	-	-	-	-	-	-	-
	b	4.8	4.8	3.2	2.9	2.6	2.5	-	-	-	-	-	-	-	-

The stated maximum payload volume in metric tons (t) include a stability margin of 33 % or are calculated at 87 % of the hydraulic lifting force in accordance with ISO 10567 standard. These values apply at the jib end when the boom-jib system is in the optimal position.

a = dozer lowered, b = in travel position, q = laterally, l = longitudinally

ACCESSOIRES

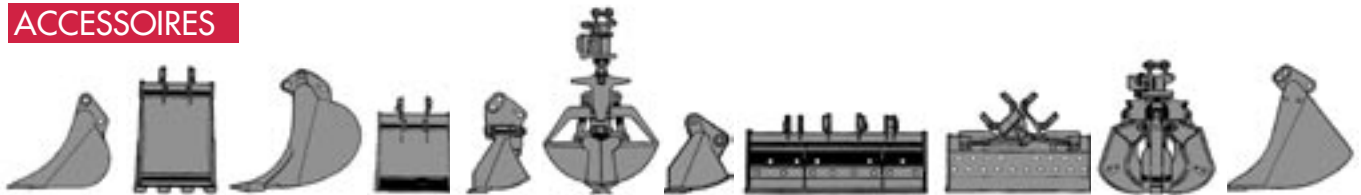

Permitted bucket attachments for max. radius F

BUCKET	F 417	F 415
Capacity l	920	670
Width mm	1100	850
max. slewing radius m	6,0	7,0

Dimensions quoted without commitment

stability acc. to ISO 10567, bulk weight 1.8 t/m³



ATLAS-TEREX GmbH
 Atlasstraße 6 · D-27777 Ganderkesee
 Tel. ++49 (0)4222/ 954-0 · Fax ++49 (0)4222/ 954-343
 info@atlas-terex.de · www.atlas-terex.de

Dealer: