



ALPHA

ENGINE

Make	: PERKINS
Type	: 1 104D-44TA Diesel Engine
Number of Cylinders	: 4 in line
Bore & Stroke	: 105 x 127 mm
Displacement	: 4400 cc
Maximum Power	: 74,5 kW, 100 HP (2200 rpm)
Maximum Torque	: 410 Nm (1 400 rpm)

High power and torque output, water cooled turbocharged diesel engine.
Compatible with USA EPA Tier 3 and European EC Stage III-A exhaust gas emission regulations

TRANSMISSION

- Autoshift transmission for heavy duty service
- Torque converter with 2,38:1 stall ratio
- Electrically controlled 2 Wheel drive or 4 Wheel Drive selection
- 6 forward, 3 reverse gears (Lock-Up option available)
- Transmission oil cooler
- A neutral circuit allows starting only when the control lever is in neutral position for safety.

AXLES

- Heavy duty service type ZF axles
- Planetary outboard type reduction gears
- Total 16 degrees oscillation on the front axle
- Equipped with LSD (Limited Slip Differential) and differential lock

TIRES

Front	: 16/70 - 20 12 Ply Rating
Rear	: 16.9 - 28 12 Ply Rating (Optional : 18.4- 26 12 Ply Rating)

CAB & HOOD

- Widened visual angle
- Ergonomic & Aesthetic Interior Design
- 3" LCD displays on both front and side panels
- High capacity A/C system
- Improved ventilating with 15 air nozzles
- ROPS and FOPS certificated cab
- Multi-functional seat
- TOPSHIFT front loader joystick
- Pool type floor mats
- Removable lids
- Cooling-box
- Storage boxes for operator
- Foldable side steps

HYDRAULIC SYSTEM

Simple, reliable and high-efficient tandem gear pump	
Main Pump Flow	: 90 lt/min (2200 rpm)
Pressure	: 227 bar
Auxiliary Pump Flow	: 57 lt/min (2200 rpm)
Pressure	: 190 bar

DRIVING SPEED

At 2200 rpm engine speed		
1 st gear	: 5.6	km/h
2 nd gear	: 8.9	km/h
3 rd gear	: 11.4	km/h
4 th gear	: 18.1	km/h
5 th gear	: 24.1	km/h
6 th gear	: 40	km/h



FILLING CAPACITIES

Engine Oil Pump	: 8	lt
Engine Cooling System	: 18.5	lt
Fuel Tank	: 140	lt
Hydraulic Oil Tank	: 70	lt
Transmission Oil	: 16	lt
Front Axle Differential	: 9	lt
Front Axle Hub Reducers	: 0.85 x 2	lt
Rear Axle Differential	: 17	lt

OPERATING WEIGHT

Operating weight (with standard equipment) : 9.100 kg



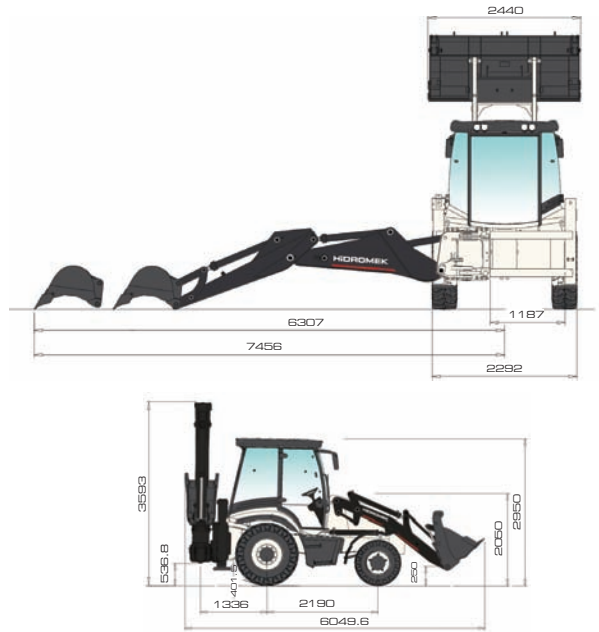
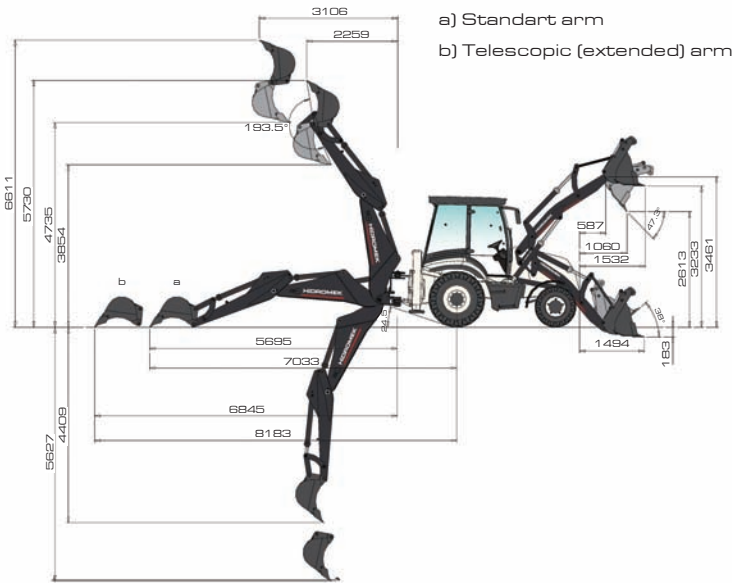

HMK102B ALPHA





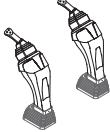

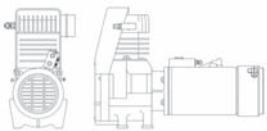
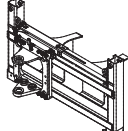

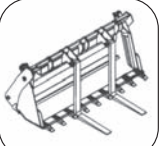
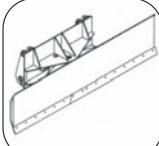

LOADER PERFORMANCE	
6 in 1 bucket capacity (m ³)	1.1
Max. bucket breakout force (kgf)	7209
Max. loading arm breakout force (kgf)	6515
Lifting capacity to maximum height (kg)	3170

BACKHOE PERFORMANCE	Standard Arm	Telescopic Arm (extended)	Telescopic Arm (retracted)
Bucket capacity (m ³)	0.17	0.17	0.17
Max. bucket breakout force (kgf)	6209	6364	6364
Max. dipper breakout force (kgf)	2983	2026	2867

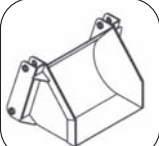
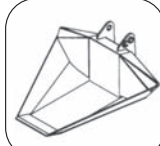
Optional Accessories

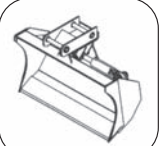
 MSS (Motion Stabilizer System)	 Joystick	 Hydraulic breaker inst. + Telescopic arm
 Air Compressor	 Powerslide	 Air conditioner

Optional Attachments

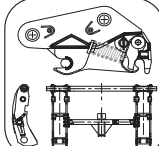
 6-in-1 Bucket with forks	 Grading blade	 Timber grab	 Special buckets	 Trapezoidal ditch bucket	 Ripper
 Offset bucket	 Clamshell grab	 Backhoe bucket of different sizes	 Hydraulic breaker	 Auger	 Quick coupler

HIDROMEK®

FACTORY - HEAD OFFICE
 Ayas yolu 25. km 1. Organize Sanayi Bölgesi Osmanlı Caddesi No: 1
 06935 Sincan / ANKARA / TURKEY
 Phone: (+90) 312 267 12 60 Fax: (+90) 312 267 21 12
 www.hidromek.com

Notice:
 HIDROMEK has the right to modify the specifications and design of the model indicated on this brochure without prior notice.